

AMB-EL-\*\*\*-A/B/C

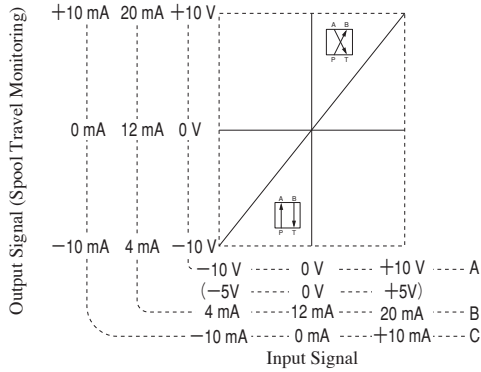

AMB-EL-\*\*\*-D/E/F

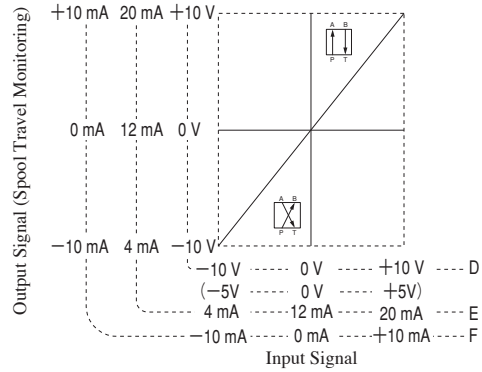

### Interchangeability in Installation Current and New Design

The power amplifier AMB-EL models were remodeled because I/O signal types were added, and the design number was changed from 10 to 20.

There are no changes to external dimensions and installation.

### Setting Adjusters

The setting adjuster supplies the command signal voltage to the power amplifier. Since the setting adjuster is closely related to actual machine operating procedure, the user generally provides this device.

Yuken makes the following standard setting adjusters for general use and designs and manufactures special setting adjusters to order.

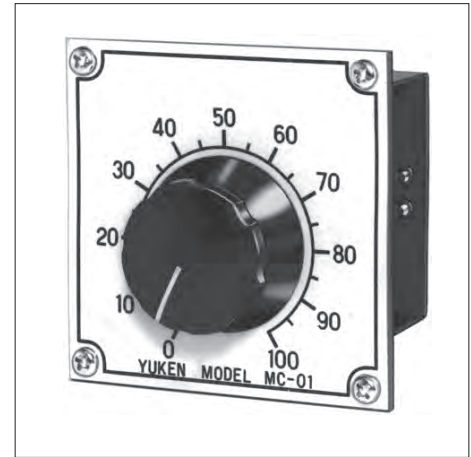

| Type                               | Model Number  | Function   |
|------------------------------------|---------------|--|
| Manually Operated Setting Adjuster | MC-01         | This is the simplest setting adjuster, consisting of a trimmer (1 kΩ) and a dial.  |
|                                    | MC-02         | Consisting of a center-tapped trimmer (1 kΩ - 1 kΩ) and a dial, this setting adjuster is ideal for a servo system.   |
| 6-point Setting Adjuster           | AMC-V6-S-*-10 | Six trimmers are incorporated, so it is possible to set six points.  |
| Multifunction Slope Controller     | AMC-T-20      | This multifunction slope controller generates any desired two-channel analog voltage pattern outputs. It can also be used with slope-proportional and time-proportional systems. |
| Slope Controller                   | AMN-T-10      | Slope and output can be set optionally 4-bit signal.   |

По вопросам продаж и поддержки обращайтесь:

Алматы (7273)495-231  
 Ангарск (3955)60-70-56  
 Архангельск (8182)63-90-72  
 Астрахань (8512)99-46-04  
 Барнаул (3852)73-04-60  
 Белгород (4722)40-23-64  
 Благовещенск (4162)22-76-07  
 Брянск (4832)59-03-52  
 Владивосток (423)249-28-31  
 Владикавказ (8672)28-90-48  
 Владимир (4922)49-43-18  
 Волгоград (844)278-03-48  
 Вологда (8172)26-41-59  
 Воронеж (473)204-51-73  
 Екатеринбург (343)384-55-89

Иваново (4932)77-34-06  
 Ижевск (3412)26-03-58  
 Иркутск (395)279-98-46  
 Казань (843)206-01-48  
 Калининград (4012)72-03-81  
 Калуга (4842)92-23-67  
 Кемерово (3842)65-04-62  
 Киров (8332)68-02-04  
 Коломна (4966)23-41-49  
 Кострома (4942)77-07-48  
 Краснодар (861)203-40-90  
 Красноярск (391)204-63-61  
 Курган (3522)50-90-47  
 Курск (4712)77-13-04  
 Липецк (4742)52-20-81

Магнитогорск (3519)55-03-13  
 Москва (495)268-04-70  
 Мурманск (8152)59-64-93  
 Набережные Челны (8552)20-53-41  
 Нижний Новгород (831)429-08-12  
 Новокузнецк (3843)20-46-81  
 Новосибирск (383)227-86-73  
 Ноябрьск (3496)41-32-12  
 Омск (3812)21-46-40  
 Орел (4862)44-53-42  
 Оренбург (3532)37-68-04  
 Пенза (8412)22-31-16  
 Пермь (342)205-81-47  
 Петрозаводск (8142)55-98-37  
 Псков (8112)59-10-37

Ростов-на-Дону (863)308-18-15  
 Рязань (4912)46-61-64  
 Самара (846)206-03-16  
 Санкт-Петербург (812)309-46-40  
 Саратов (8342)22-96-24  
 Саратов (845)249-38-78  
 Севастополь (8692)22-31-93  
 Симферополь (3652)67-13-56  
 Смоленск (4812)29-41-54  
 Сочи (862)225-72-31  
 Ставрополь (8652)20-65-13  
 Сургут (3462)77-98-35  
 Сыктывкар (8212)25-95-17  
 Тамбов (4752)50-40-97  
 Тверь (4822)63-31-35

Тольятти (8482)63-91-07  
 Томск (3822)98-41-53  
 Тула (4872)33-79-87  
 Тюмень (3452)66-21-18  
 Улан-Удэ (3012)59-97-51  
 Ульяновск (8422)24-23-59  
 Уфа (347)229-48-12  
 Хабаровск (4212)92-98-04  
 Чебоксары (8352)28-53-07  
 Челябинск (351)202-03-61  
 Череповец (8202)49-02-64  
 Чита (3022)38-34-83  
 Якутск (4112)23-90-97  
 Ярославль (4852)69-52-93

**Manually Operated Setting Adjuster**

**MC-01**

**[Electric Circuit]**

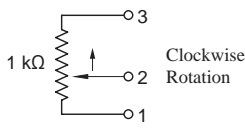

**[Example Diagram]**

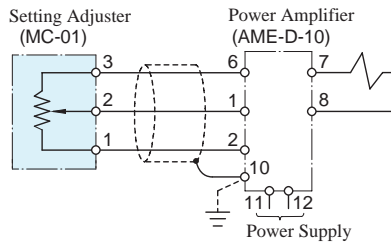

**[Mounting Panel]**

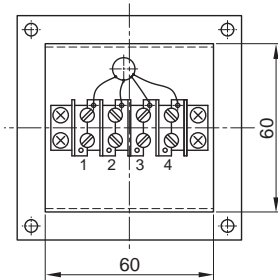
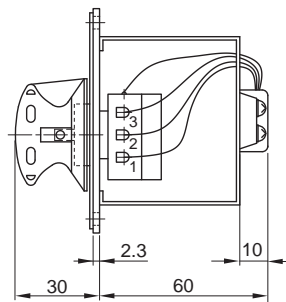
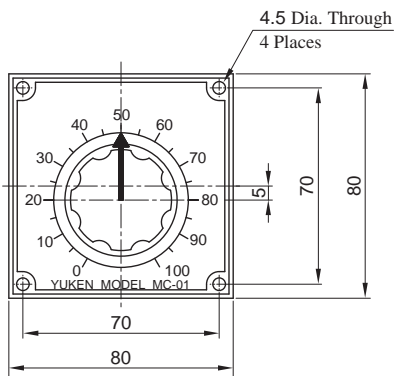
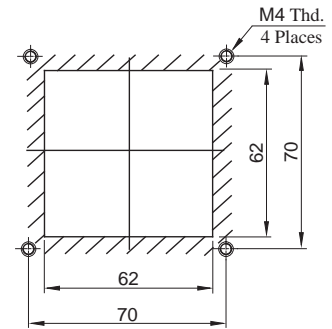

Approx. Mass.....0.5 kg

**MC-02**

**[How to Use]**

This setting adjuster is for using positive and negative voltages to the right and left of the zero point. Most suitable for servo systems. Please contact us for usage details.

**[Electric Circuit]**

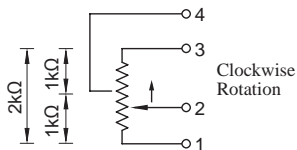

**[Example Diagram]**

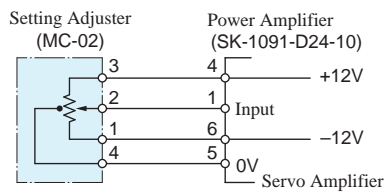

**[Mounting Panel]**

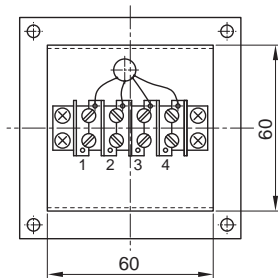
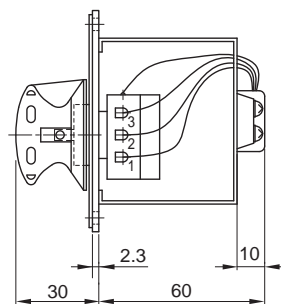
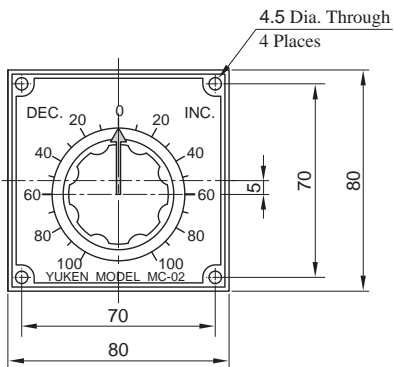
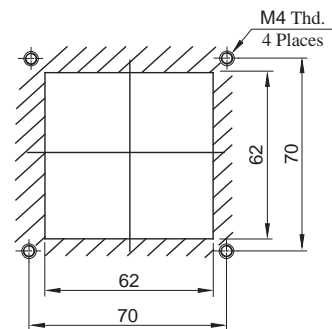

Approx. Mass.....0.5 kg

## 6-Point Setting Adjuster

### AMC-V6-S-\*-10

Power Supply  
 100 ..... 100 V AC  
 200 ..... 200 V AC  
 220 ..... 220 V AC

#### [Electric Circuit]

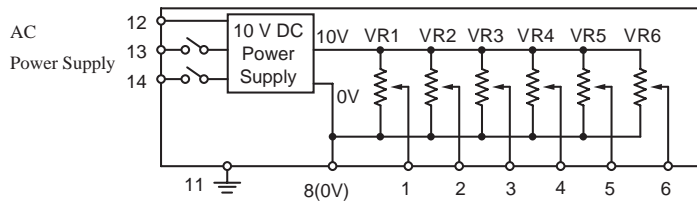

#### ● Detail of Terminal Board

| Terminal Number | Name         |
|-----------------|--------------|
| 1               | 1 OUT (VR1)  |
| 2               | 2 OUT (VR2)  |
| 3               | 3 OUT (VR3)  |
| 4               | 4 OUT (VR4)  |
| 5               | 5 OUT (VR5)  |
| 6               | 6 OUT (VR6)  |
| 7               | —            |
| 8               | 0V COM       |
| 9               | —            |
| 10              | —            |
| 11              | Ground G     |
| 12              | —            |
| 13              | Power Supply |
| 14              |              |

#### [Example Diagram]

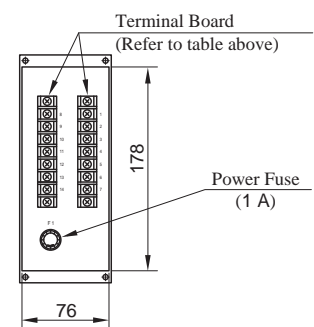
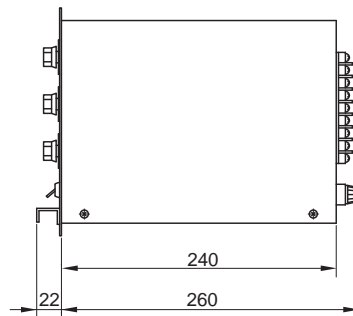
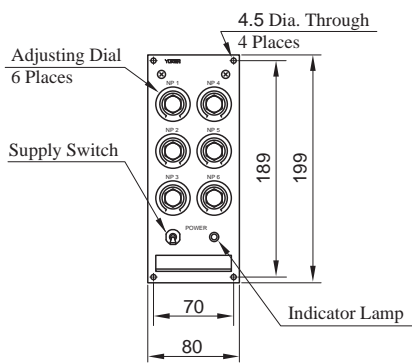
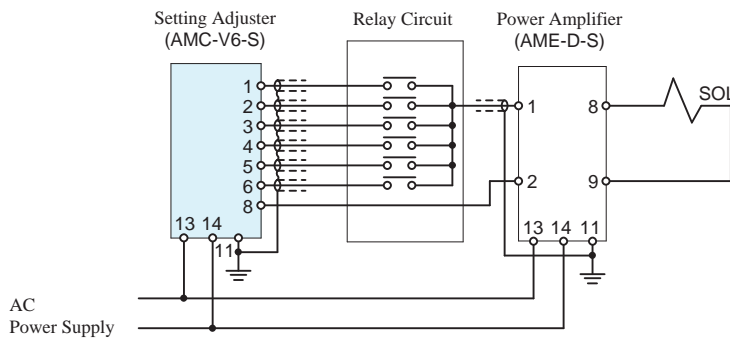

Approx. Mass.....1.6 kg

## Multifunction Slope Controllers

This controller can generate any desired two-channel analog voltage pattern outputs and can be used with slope-constant and time-constant systems. Although two-channel outputs can be used independently, this controller can also be used as a setting adjuster for the EH Series variable piston pumps.



### Model Number Designation

| AMC                           | -T  | -20           |
|-------------------------------|---|---------------|
| Series Number                 | Type of Function  | Design Number |
| <b>AMC</b> : Setting Adjuster | <b>T</b> : Acceleration/Deceleration Signal Type (Slope Controller) | <b>20</b>     |

### Specifications

| Model No.   | AMC-T-20  |
|---|---|
| Descriptions                                      |   |
| Number of Output Channels                         | 2 Channels (A, B)   |
| Maximum Output Range                              | 0 - +5 V *, 0 - ±5 V, 0 - +10 V, 0 - ±10 V (The settings are DIP switch selectable)   |
| Two Categories of Slopes                          | Slope-constant * 5s/Max. output voltage<br>With a level change, the slope will not change (but arrival time changes.)<br>Time-constant 5s<br>With a level change, the time will not change (but the slope changes.) <span style="float: right;">} (to be selected by DIP switch)</span>   |
| Acceleration/Deceleration Signal Type             | 4 Types Polygonal Line Signal * : 1 Type (to be selected by DIP switch)<br>Curve Compensation Signal : 3 Types  |
| Max. Slope Time                                   | 5 s *, 20 s, 50 s, 100 s (The settings are DIP switch selectable)   |
| Setting Resolution                                | The level and slope settings are variable in 0.1% units from 0 to ±99.9%  |
| Control Mode Number of Preselected Patterns       | Mode 1, 4-bit binary code input, 15 patterns<br>Mode 2, 6-bit binary code input, 63 patterns<br>Mode 3, Timer control, 9 patterns (4 variations)  |
| Stop Mode<br>(Applicable Only for Control Mode 1) | ON : The stop mode is to retain the state of controller output at the instant an external input signal is interrupted. When the external signal is input again, the operation is resumed from the retained state.<br>OFF * : When external input signal is interrupted, function goes back to the initial setting (Pattern No.0). |
| Control Input Signal                              | Current input type, 10 mA /bit max.<br>Usable as a voltage input type (voltage range: 8 to 48 V DC) Photocoupler insulation input   |
| Control Output Signal                             | Output from transistor open collector<br>Max. 30 V, 50 mA   |
| Data Save   | EEP-ROM (Battery not needed)  |
| Power Supply                                      | 100/200 V AC, 50/60 Hz (85 - 260 V AC)  |
| Power Input                                       | 10 VA or less   |
| Ambient Temperature                               | 0 - 50°C  |
| Ambient Humidity                                  | 85% RH or less (Bedewing must be avoided)   |
| Approx. Mass                                      | 1 kg  |

Note) \* Indicates preset conditions.

### Instructions

- Since this controller incorporates a micro computer, do subject it to undue electrical noise.

## Control Modes

One among the following three types of control modes can be chosen by changing DIP switch.

### Control Mode 1

Channels A and B generate optional slopes independently each other.

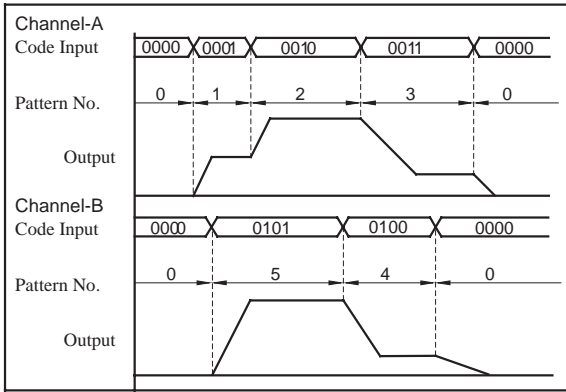

### Control Mode 2

A slope is generated by a strobe signal (signal for change to next signal). Channels A and B operate synchronously.

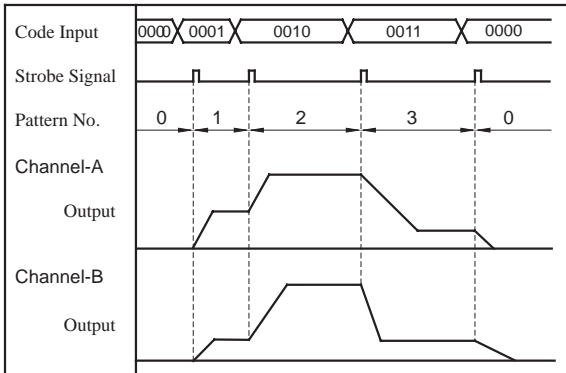

### Control Mode 3

The internal timer is activated by a start signal, causing the slopes to be generated successively in memory. Channels A and B operate independently.

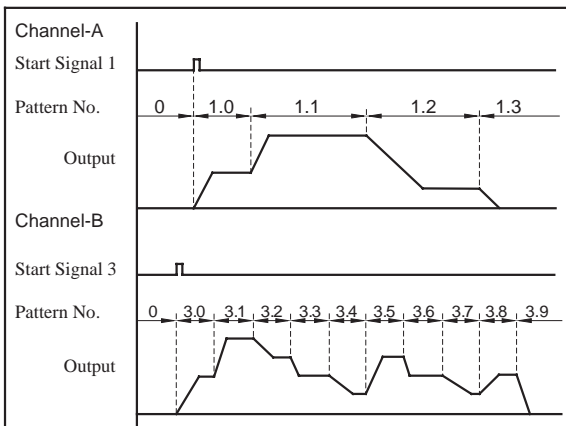

## Setting Example

### Control Mode 1 Channel - A

| Code Input |     |     |     | Pattern No. | Setting % |       | Remarks                        |
|------------|-----|-----|-----|-------------|-----------|-------|--------------------------------|
| A8         | A4  | A2  | A1  |             | Level     | Slope |                                |
| OFF        | OFF | OFF | OFF | 0           | 0         | 0     | Stop                           |
| OFF        | OFF | OFF | ON  | 1           | 99.9      | 40.0  | Cylinder forward acceleration  |
| OFF        | OFF | ON  | OFF | 2           | -80.0     | 60.0  | Cylinder backward acceleration |
| OFF        | OFF | ON  | ON  | 3           | 10.0      | 50.0  | Cylinder forward deceleration  |
| ~~~~~      |     |     |     |             |           |       |                                |
| ON         | ON  | ON  | ON  | 15          | 10.0      | 10.0  |                                |

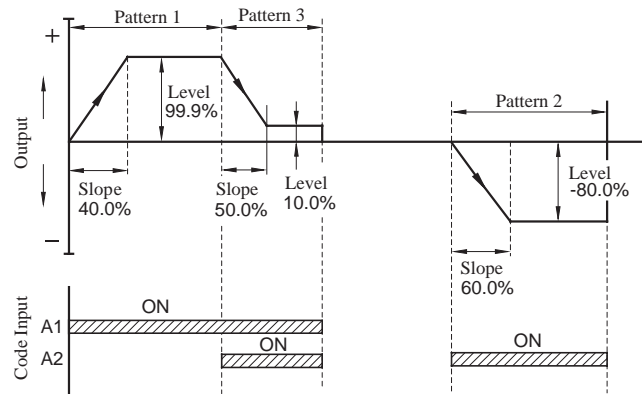

## Slope Type

One among the following four types can be chosen by changing DIP switch.

### Type 1

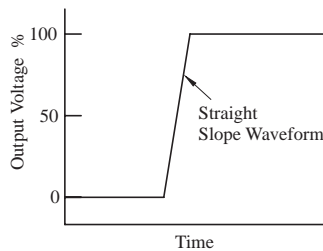

### Type 2

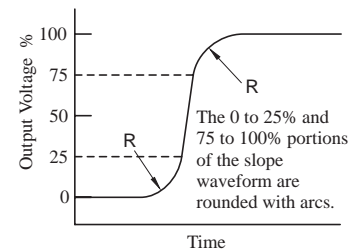

### Type 3

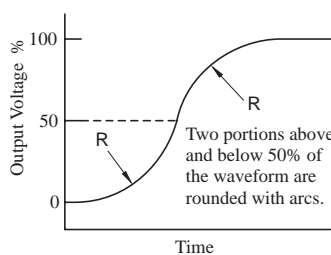

### Type 4

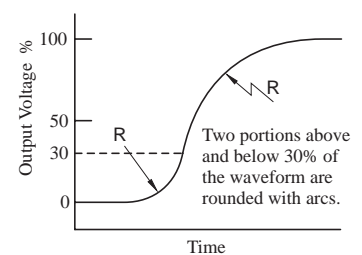

**AMC-T-20**

[Example Diagram]

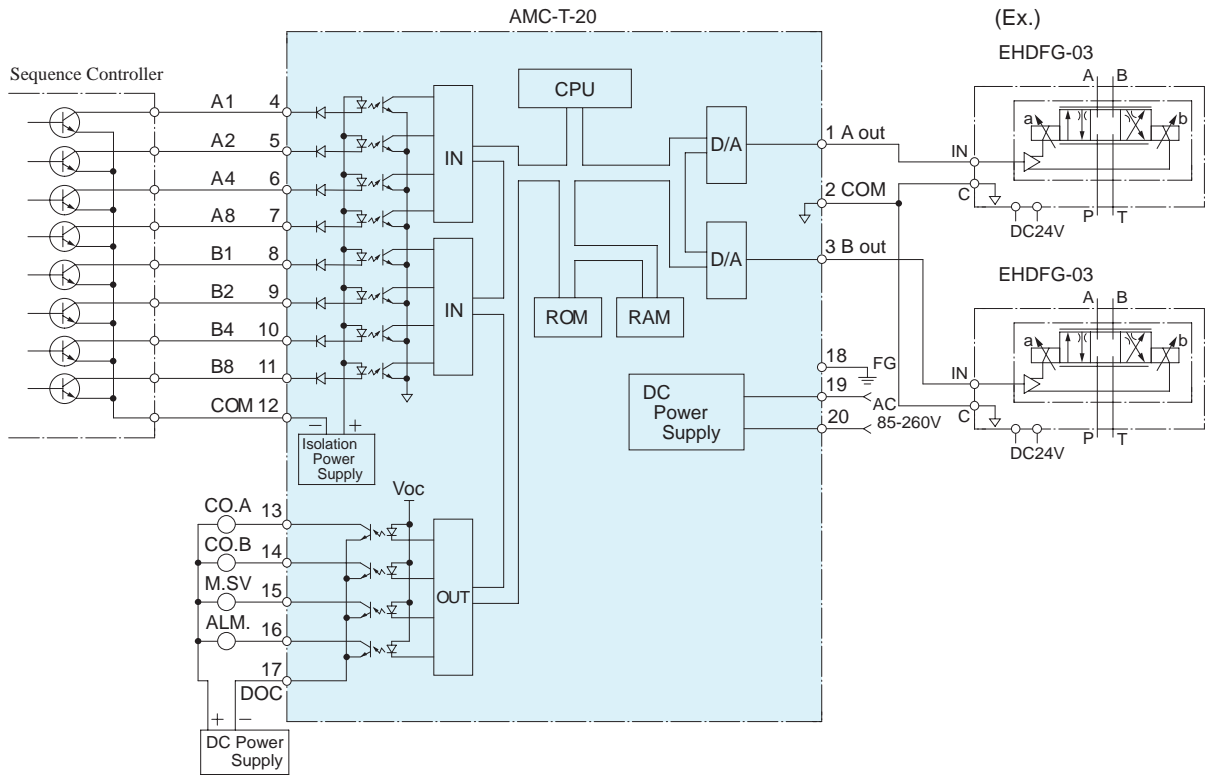

● Detail of Terminal Board

| Terminal Number | Name             | Terminal Number | Name                                     |
|-----------------|------------------|-----------------|--|
| 1               | Channel A Output | 11              | Code Input B8                            |
| 2               | Common           | 12              | Code Input Common DCOM                   |
| 3               | Channel B Output | 13              | Coincidental Output Signal with "A" CO.A |
| 4               | Code Input A1    | 14              | Coincidental Output Signal with "B" CO.B |
| 5               | Code Input A2    | 15              | Data Save Signal M.SV                    |
| 6               | Code Input A4    | 16              | Alarm Signal Output ALM.                 |
| 7               | Code Input B1    | 17              | Output Common DOC                        |
| 8               | Code Input B2    | 18              | Frame Ground FG                          |
| 9               | Code Input B4    | 19              | Power Supply AC                          |
| 10              | Code Input       | 20              |  |

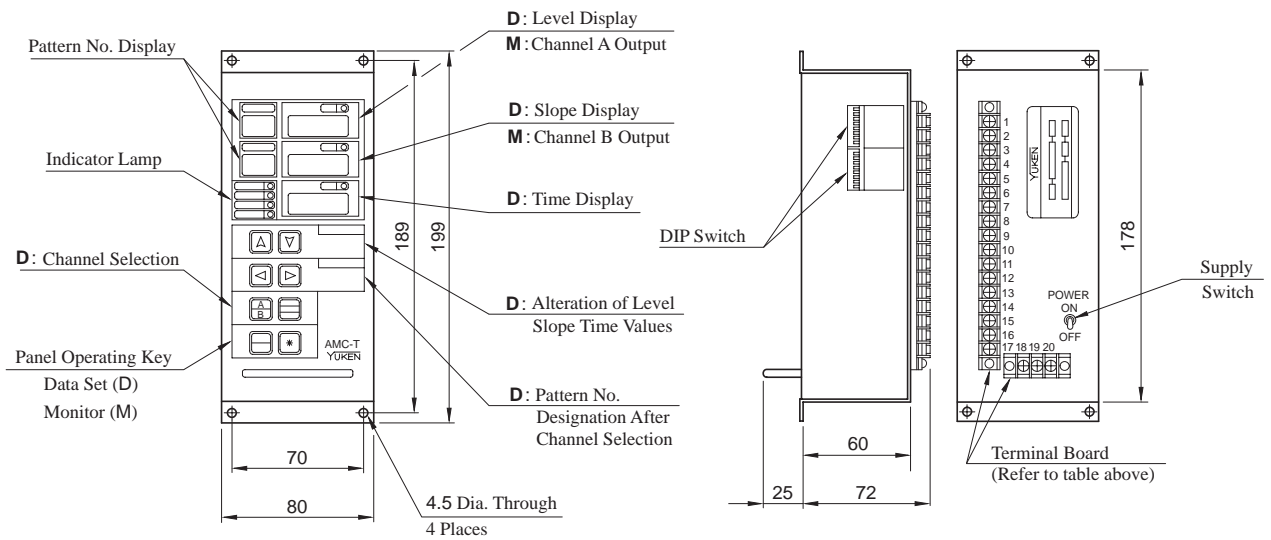

Setting Adjusters

## Slope Controllers

This slope controller is considerably smaller and lighter compared to conventional slope controllers.

4-bit switching signals allow the pattern output of given levels and acceleration/deceleration times. One-touch disconnection is supported.

The mass and the volume have been reduced to one-fifth and one-fourth, respectively.

### Model Number Designation

| AMN           | -T                          | -10           |
|---------------|-----------------------------|---------------|
| Series Number | Type of Function            | Design Number |
| <b>AMN</b>    | <b>T</b> : Slope Controller | <b>10</b>     |



### Specifications

| Model Numbers                         | AMN-T-10  |
|---------------------------------------|---|
| Descriptions                          |   |
| Number of Output Channels             | 1 Channel   |
| Maximum Output Range                  | 0 - +5 V (Factory Preset)<br>0 - +10 V<br>5 V<br>10 V   |
| Maximum Slope Time                    | <ul style="list-style-type: none"> <li>Slope-constant type: ★1<br/>1-9999 s/Max. Output Signal (Factory Setting, 5 s)</li> <li>Time-constant type: ★2 1-9999 s (Can be set in 1 second increments)</li> </ul> |
| Acceleration/Deceleration Signal Type | Polygonal Line Signal: 1 Type (Factory Setting)<br>Curve Compensation Signal: 3 Type  |
| Setting Resolution                    | The level and slope setting are variable in 0.1 % units from 0 to 99.9%   |
| Number of Preselected Patterns        | 4-bit binary code input<br>15 patterns  |
| Sequence Input                        | Input Current: 10 mA/24 V<br>Voltage Range: 10 - 28 V   |
| Sequence Output                       | Load Current: Max. 50 mA<br>Supply Voltage: Max. 32 V   |
| Power Supply Voltage                  | 24 VDC (20 - 30 VDC)  |
| Power Input                           | 3 W   |
| Ambient Temperature                   | 0 - 50°C  |
| Ambient Humidity                      | 90 % RH or less   |
| Approx. Mass                          | 0.2 kg  |

- ★1. A fixed slope means that the slope endpoint time changes while the slope gradient remains unchanged when the level is changed.
- ★2. A fixed time means that the slope endpoint time remains unchanged when the level is changed.
- ★3. The same slope types as those for the multifunction slope controller are supported. See page H-198 for details.

### Instructions

- Since this controller incorporates a micro computer, do subject it to undue electrical noise.

### AMN-T-10

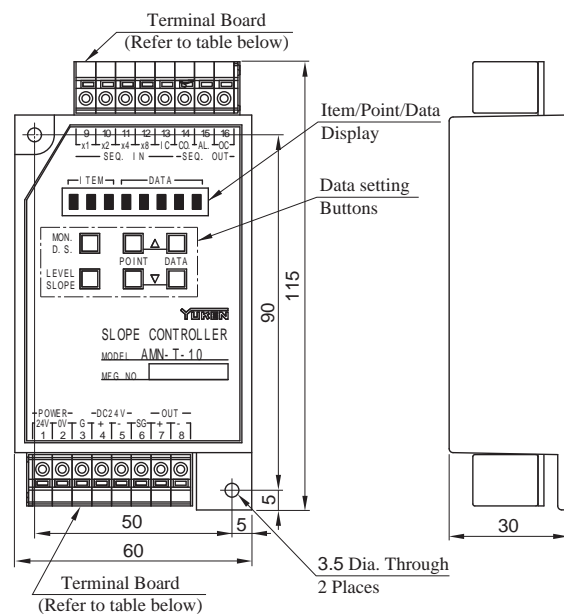

### ● Detail of Terminal Board

| Terminal Number | Name                       | Terminal Number | Name                    |
|-----------------|----------------------------|-----------------|-------------------------|
| 1               | Power Supply +24V          | 9               | Sequence Input x1       |
| 2               | Power Supply 0V            | 10              | Sequence Input x2       |
| 3               | Frame Ground G             | 11              | Sequence Input x4       |
| 4               | Internal Power Supply +24V | 12              | Sequence Input x8       |
| 5               | Internal Power Supply 0V   | 13              | Sequence Input IN COM   |
| 6               | Signal Ground SG           | 14              | Sequence Output COL N.  |
| 7               | Output Signal +            | 15              | Sequence Output ALARM   |
| 8               | Output Signal -            | 16              | Sequence Output OUT COM |

### [Example Diagram]

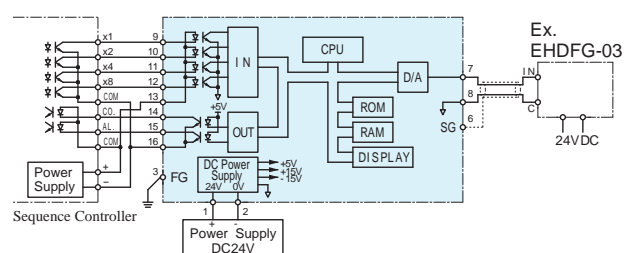

## Interchangeability between Current and New Design

### Specifications

Specifications unchanged unless specified below.

| Descriptions                                      | Model No. | New : AMC-T-20  | Current : AMC-T-10  |
|---|-----------|---|---|
| Control Output Signal                             |           | Output from transistor open collector<br>Max. 30 V, 50 mA             | Output from transistor open collector<br>Max. 30 V, 10 mA |
| Slope Types                                       | 4 Types   | Polygonal Line Signal : 1 Type<br>Curve Compensation Signal : 3 Types | 1 Type : Polygonal Line Signal                            |
| Stop Mode<br>(Applicable only for Control Mode 1) |           | ON, OFF   | —   |
| Data Save   |           | EEP-ROM Battery not needed  | Battery Required  |
| Approx. Mass                                      |           | 1 kg  | 1.8 kg  |

### Terminal

The following are differences between current and new.

| Terminal Number | Name  |  | Remarks   |
|-----------------|---|--|---|
|                 | New : Design 20                               | Current : Design 10                          |   |
| 13              | Coincidental Output Signal with "A"<br>"CO.A" | Coincidental Output Signal with "A"<br>"DO1" | Abbreviation of the terminals are changed though functionally the same. |
| 14              | Coincidental Output Signal with "B"<br>"CO.B" | Coincidental Output Signal with "B"<br>"DO2" |   |
| 15              | Data Save Signal<br>"M.SV"                    | —  | Added new functions.  |
| 16              | Alarm Signal Output<br>"ALM."                 | —  |   |

### Interchangeability in Installation

There is an interchangeability in installation, although depths (dimensions "A" and "B") are different.

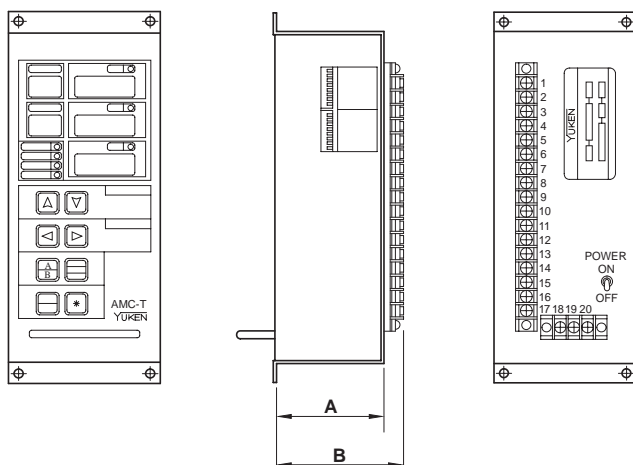

| Model Numbers |          | mm  |     |
|---------------|----------|-----|-----|
|               |          | A   | B   |
| Current       | AMC-T-10 | 185 | 200 |
| New           | AMC-T-20 | 60  | 72  |

По вопросам продаж и поддержки обращайтесь:

Алматы (7273)495-231  
Ангарск (3955)60-70-56  
Архангельск (8182)63-90-72  
Астрахань (8512)99-46-04  
Барнаул (3852)73-04-60  
Белгород (4722)40-23-64  
Благовещенск (4162)22-76-07  
Брянск (4832)59-03-52  
Владивосток (423)249-28-31  
Владикавказ (8672)28-90-48  
Владимир (4922)49-43-18  
Волгоград (844)278-03-48  
Вологда (8172)26-41-59  
Воронеж (473)204-51-73  
Екатеринбург (343)384-55-89

Иваново (4932)77-34-06  
Ижевск (3412)26-03-58  
Иркутск (395)279-98-46  
Казань (843)206-01-48  
Калининград (4012)72-03-81  
Калуга (4842)92-23-67  
Кемерово (3842)65-04-62  
Киров (8332)68-02-04  
Коломна (4966)23-41-49  
Кострома (4942)77-07-48  
Краснодар (861)203-40-90  
Красноярск (391)204-63-61  
Курган (3522)50-90-47  
Курск (4712)77-13-04  
Липецк (4742)52-20-81

Магнитогорск (3519)55-03-13  
Москва (495)268-04-70  
Мурманск (8152)59-64-93  
Набережные Челны (8552)20-53-41  
Нижний Новгород (831)429-08-12  
Новокузнецк (3843)20-46-81  
Новосибирск (383)227-86-73  
Ноябрьск (3496)41-32-12  
Омск (3812)21-46-40  
Орел (4862)44-53-42  
Оренбург (3532)37-68-04  
Пенза (8412)22-31-16  
Пермь (342)205-81-47  
Петрозаводск (8142)55-98-37  
Псков (8112)59-10-37

Ростов-на-Дону (863)308-18-15  
Рязань (4912)46-61-64  
Самара (846)206-03-16  
Санкт-Петербург (812)309-46-40  
Саранск (8342)22-96-24  
Саратов (845)249-38-78  
Севастополь (8692)22-31-93  
Симферополь (3652)67-13-56  
Смоленск (4812)29-41-54  
Сочи (862)225-72-31  
Ставрополь (8652)20-65-13  
Сургут (3462)77-98-35  
Сыктывкар (8212)25-95-17  
Тамбов (4752)50-40-97  
Тверь (4822)63-31-35

Тольятти (8482)63-91-07  
Томск (3822)98-41-53  
Тула (4872)33-79-87  
Тюмень (3452)66-21-18  
Улан-Удэ (3012)59-97-51  
Ульяновск (8422)24-23-59  
Уфа (347)229-48-12  
Хабаровск (4212)92-98-04  
Чебоксары (8352)28-53-07  
Челябинск (351)202-03-61  
Череповец (8202)49-02-64  
Чита (3022)38-34-83  
Якутск (4112)23-90-97  
Ярославль (4852)69-52-93

Россия +7(495)268-04-70

Казахстан +7(7172)727-132

Киргизия +996(312)96-26-47

yne@nt-rt.ru || <https://yuken.nt-rt.ru>