

Алматы (7273)495-231
 Ангарск (3955)60-70-56
 Архангельск (8182)63-90-72
 Астрахань (8512)99-46-04
 Барнаул (3852)73-04-60
 Белгород (4722)40-23-64
 Благовещенск (4162)22-76-07
 Брянск (4832)59-03-52
 Владивосток (423)249-28-31
 Владикавказ (8672)28-90-48
 Владимир (4922)49-43-18
 Волгоград (844)278-03-48
 Вологда (8172)26-41-59
 Воронеж (473)204-51-73
 Екатеринбург (343)384-55-89

Иваново (4932)77-34-06
 Ижевск (3412)26-03-58
 Иркутск (395)279-98-46
 Казань (843)206-01-48
 Калининград (4012)72-03-81
 Калуга (4842)92-23-67
 Кемерово (3842)65-04-62
 Киров (8332)68-02-04
 Коломна (4966)23-41-49
 Кострома (4942)77-07-48
 Краснодар (861)203-40-90
 Красноярск (391)204-63-61
 Курган (3522)50-90-47
 Курск (4712)77-13-04
 Липецк (4742)52-20-81

Магнитогорск (3519)55-03-13
 Москва (495)268-04-70
 Мурманск (8152)59-64-93
 Набережные Челны (8552)20-53-41
 Нижний Новгород (831)429-08-12
 Новокузнецк (3843)20-46-81
 Новосибирск (383)227-86-73
 Ноябрьск (3496)41-32-12
 Омск (3812)21-46-40
 Орел (4862)44-53-42
 Оренбург (3532)37-68-04
 Пенза (8412)22-31-16
 Пермь (342)205-81-47
 Петрозаводск (8142)55-98-37
 Псков (8112)59-10-37

Ростов-на-Дону (863)308-18-15
 Рязань (4912)46-61-64
 Самара (846)206-03-16
 Санкт-Петербург (812)309-46-40
 Саранск (8342)22-96-24
 Саратов (845)249-38-78
 Севастополь (8692)22-31-93
 Симферополь (3652)67-13-56
 Смоленск (4812)29-41-54
 Сочи (862)225-72-31
 Ставрополь (8652)20-65-13
 Сургут (3462)77-98-35
 Сыктывкар (8212)25-95-17
 Тамбов (4752)50-40-97
 Тверь (4822)63-31-35

Тольятти (8482)63-91-07
 Томск (3822)98-41-53
 Тула (4872)33-79-87
 Тюмень (3452)66-21-18
 Улан-Удэ (3012)59-97-51
 Ульяновск (8422)24-23-59
 Уфа (347)229-48-12
 Хабаровск (4212)92-98-04
 Чебоксары (8352)28-53-07
 Челябинск (351)202-03-61
 Череповец (8202)49-02-64
 Чита (3022)38-34-83
 Якутск (4112)23-90-97
 Ярославль (4852)69-52-93

Россия +7(495)268-04-70

Казахстан +7(7172)727-132

Киргизия +996(312)96-26-47

yne@nt-rt.ru || <https://yuken.nt-rt.ru>

ASR Series AC Servo Motor Driven Pumps

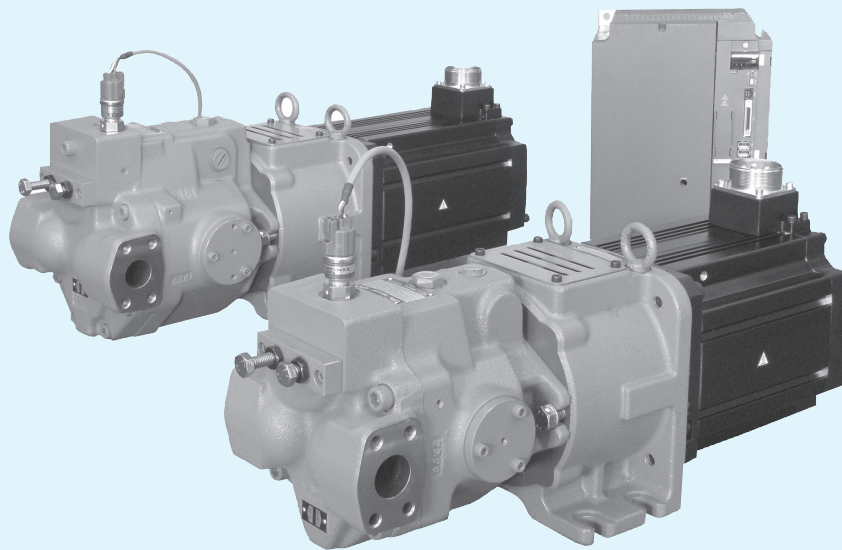

“ASR” Series AC Servo Motor Driven Pumps

Pump Type	Graphic Symbols	Geometric Displacement cm ³ /rev					Maximum Operating Pressure MPa	Page
		0	2	5	10	20		
ASR Series AC Servo Motor Driven Pumps	 Single Displacement Type	ASR1					21	A-214
		ASR2					16	
	ASR3					21		
	ASR5							
	ASR10							
	 Dual Displacement Type							

Hydraulic Fluids

Hydraulic Fluids

Use clean petroleum base oils equivalent to ISO VG32 or 46. The recommended viscosity range is from 20 to 400 mm²/s and temperature range is from 0 to 60 °C, both of which have to be satisfied for the use of the above hydraulic oils.

Control of Contamination

Due caution must be paid to maintaining control over contamination of the operating oil which can otherwise lead to breakdowns and shorten the life of the unit. Please maintain the degree of contamination within NAS class 9.

The suction port must be equipped with at least 100 μm (150 mesh) reservoir type filter and the return line must have a line type filter of under 10 μm.

Instructions

Transportation

For transportation, use the lifting rings on the pump. Do not use lifting cables at places other than the lifting rings.

Mounting

When installing the pump, the filling port should be positioned upwards.

Suction Pressure

Permissible suction pressure at the inlet port of the pump is between -16.7 and +50 kPa. For piping to the suction port, use pipes of the nominal diameters shown below. Make sure that the height of the pump suction port is lower than the oil level in the reservoir.

Model	Nominal Dia.
ASR1/ASR2	3/4
ASR3/ASR5	1 1/4
ASR10	2

Hints on Piping

When using steel pipes for the suction or discharge ports, excessive load from the piping to the pump generates excessive noise. Whenever there is fear of excessive load, please use rubber hoses.

Drain Piping

Install drain piping according to the chart and ensure that pressure within the pump housing should be maintained at a nominal pressure of less than 0.1 MPa and surge pressure of less than 0.5 MPa.

The length of piping should be less than 1 m. Instead of joining the drain pipe to other return lines, run it independently. The pipe end should be submerged in oil.

[Recommended Drain Piping Size]

Model	Fitting Size	Inside Dia. of Pipe
ASR1/ASR2	3/8 (Inside Dia. 8.5 mm or more)	10 mm or more
ASR3	1/2 (Inside Dia. 12 mm or more)	12 mm or more
ASR5/ASR10	3/4 (Inside Dia. 16 mm or more)	19 mm or more

Starting

Before first starting, fill the pump case with clean operating oil via the filling port. In order to avoid air blockage when first starting, adjust the control valves so that the discharged oil from the pump is returned directly to the reservoir or the actuator moves in a free load.

Bleeding Air

It may be necessary to bleed air from the pump case and lines to remove causes of vibration. An air bleed valve (Model Number: ST1004-*-10*, Page A-259) in the outlet line is recommended. For air bleeding with an air bleed valve installed, run the pump at a rotational speed that provides a flow rate equal to/higher than the valve's flow rate to reseating.

[Volume of Pre-fill Oil Required]

Model	Volume cm ³
ASR1/ASR2	600
ASR3/ASR5	1200
ASR10	2500

Setting Safety Valve (Pressure) and Delivery

At the time of shipment, the unit has been preset to the delivery rate shown below; the safety valve has been set to 21 MPa (19.5 MPa for ASR2). Adjust the preset delivery and safety valve (pressure) to meet your system requirements.

[Default Setting of Delivery]

Model Numbers	Single Displacement Type "X"cm ³ /rev	Dual Displacement Type "W"cm ³ /rev	
		Large Displacement	Small Displacement
ASR1	15.8	15.8	8
ASR2	22.2	22.2	8
ASR3	36.9	36.9	10
ASR5	56.2	56.2	14
ASR10	100	100	20

Adjustment of Delivery

Turning the flow adjustment screw for the single displacement type or the large displacement side flow adjustment screw for the dual displacement type clockwise decreases delivery. Turning the small displacement side flow adjustment screw for the dual displacement type clockwise increases delivery.

[Volume adjusted by each full turn of the flow adjustment screw]

Model Numbers	Single Displacement Type "X"cm ³ /rev	Dual Displacement Type "W"cm ³ /rev	
		Large Displacement	Small Displacement
ASR1	1.4	1.4	1.5
ASR2	2.0	2.0	2.1
ASR3	2.9	2.9	2.8
ASR5	3.9	3.9	3.7
ASR10	5.4	5.4	7.9

★ For the relationship between the flow adjustment screw position and flow adjustment, see pages A-217 and A-218.

Adjustment of Safety Valve (Pressure)

• Single Displacement Type

Turning the pressure adjustment screw clockwise increases pressure.

See the chart for the pressure change per turn of the adjustment screw. After adjustment, be sure to tighten the lock nut.

Model Numbers	Pressure Change Per Turn MPa	Max. Setting Value MPa	Min. Setting Value MPa
ASR1/ASR3/ASR5-**-HX	4.4	24.8	8
ASR10-**-HX			2
ASR2-*C-CX		19.5	2

★ For the relationship between the pressure adjustment screw position and pressure adjustment, see page A-217.

• Dual Displacement Type

The dual displacement type does not support the full cut-off function. Provide a safety valve on the pump discharge side. Set the safety valve at a value of the maximum operating pressure + 3 to 3.5 MPa.

Precautions During Operation

During and for a period after operation, the surface temperature of the AC servo motor and the pump will be hot. Prevent hands and other body parts from coming into contact with them.

Providing flexible flow/pressure control !

ASR Series AC Servo Motor Driven Pumps

The ASR series provides variable flow by driving a piston pump directly with an AC servo motor and controlling the rotational speed in a range from zero to the maximum level. This series allows precise control of flow/pressure by using a dedicated AMSR controller. It also offers excellent response and repeatability.

System Configuration

A feedback loop is formed by the AMSR controller that computes deviations between control signals from the machine side (speed and pressure commands) and sensor signals to drive the AC servo motor accordingly. Control parameters can be set digitally by using dedicated software.

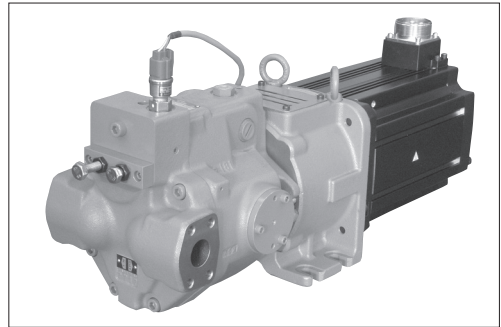
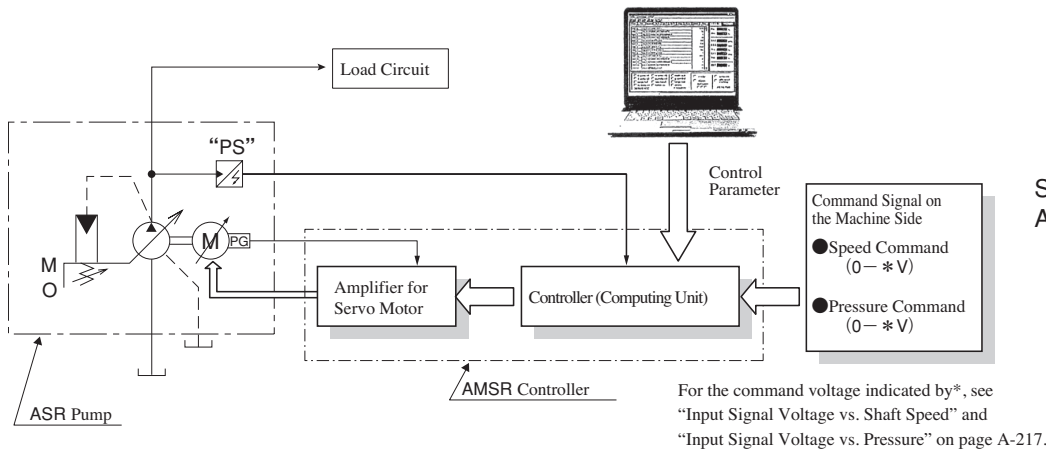

Graphic Symbols

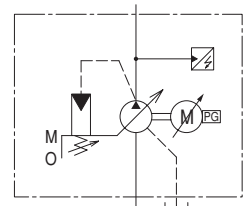

Single Displacement Type
ASR * - * * - * X * -

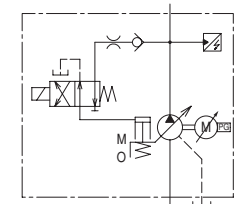

Dual Displacement Type
ASR * - * * - * W * -

Energy saving with low heat generation

These pumps run at a rotational speed suitable for mechanical requirements, eliminating unnecessary power loss. They minimize heat generation in the fluid and allow the use of a significantly smaller reservoir.

Example of Power Consumption by Pump Control Type

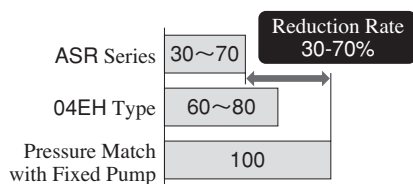

Low noise

The motor operates at near-zero speed during unloaded operation or pressure control, keeping the noise level extremely low.

High performance

The AC servo motor, which directly controls the pump speed, improves response and stability at low pressures and speeds.

Digital AMSR controller that saves space and wiring

The integration of the amplifier for the servo motor and the controller saves space and wiring. The parameters can be digitally adjusted in an easy and repeatable way.

Dual displacement type for a wider operation range

The dual displacement type has a solenoid operated directional valve to switch between large and small swash plate angles. A single pump unit of the dual displacement type can operate both with low pressure/large flow and with high pressure/small flow. Thus, in comparison to the single displacement type with the same motor capacity, the dual displacement type covers a significantly wider range of operating pressures and flow rates.

Large flow

The AMSR controller has a combination function that supports operation with large flow up to 3200 L/min (ASR10 x 16 units).

Specifications

Descriptions		Model Numbers								
		ASR1-	ASR2-	ASR3-		ASR5-	ASR10-			
Power Capacity		C	C	E	G	J	M			
Pump	Flow Control	Max. Flow	39.5 L/min	55.5 L/min	92.3 L/min		129 L/min	200 L/min		
		Min. Adj. Flow	1%							
		Hysteresis	1% or less							
		Repeatability	1% or less							
		Input Signal Voltage	31.6 L/min / 5V	44.4 L/min / 5V	73.8 L/min / 5V	112.4 L/min / 5V		200 L/min / 5V		
		Max. Permissible Input Signal Voltage*	39.5 L/min / 6.25V	55.5 L/min / 6.25V	92.3 L/min / 6.25V	129 L/min / 5.75V				
	Pres. Control	Max. Operating Pres.	21 MPa	16 MPa	21 MPa					
		Min. Adj. Pres.	0.1 MPa							
		Hysteresis	1% or less							
		Repeatability	1% or less							
		Input Signal Voltage	17.5 MPa / 5V	16 MPa / 4.57V	17.5 MPa / 5V					
		Max. Permissible Input Signal Voltage*	21 MPa / 6V		21 MPa / 6V					
AC Servo Motor Specifications	Rated Output	4.5 kW			6 kW	8 kW	11 kW	15 kW		
	Insulation Class	Class F								
	Cooling System	Totally-enclosed Self-cooling					Totally-enclosed Fan-cooling			
		Cooling Fan Power Consumption	—					62W (50Hz)/76W (60Hz)		
	Environmental Condition	Ambient Temperature	0 - +40 °C (No Freezing)							
Ambient Humidity		80 %RH or less (No Condensation)								
Mass	Single Displacement Type	54 kg	54 kg	80 kg	87 kg	94 kg	175.5 kg	213 kg	233 kg	
	Dual Displacement Type	55 kg	55 kg	82 kg	89 kg	96 kg	177.5 kg	214 kg	234 kg	
Applicable Controller Model Number		AMSR- *C- *00-10			AMSR- 2DE- *00-10	AMSR- *FGI- *00-10		AMSR- *HJL- *00-10	AMSR- *KMO- *00-10	

*By adjusting the controller, the maximum flow rate/5 V (39.5 L/min/5 V) and the maximum operating pressure/5 V (21 MPa/5 V) can be set.

Model Number Designation

The model numbers below indicate packages each containing an AC servo motor driven pump, AMSR controller, and Regeneration Resistors.

ASR3	-4	G	-H	X	S	A100	N	-A	00	-12
Series Number	Power Supply Voltage	Power Capacity	Max. Operating Pres.	Flow Setting	Port Direction	Coil Type for Solenoid Operated Directional Valve	Electrical Conduit Connection for Solenoid Operated Directional Valve	Function Selection	Parameter Number	Design Number
ASR1	None : 200 V AC 4 : 400 V AC	C	H : 21 MPa	X : Single Displacement Type W : Dual Displacement Type	S : Side None : Axial	AC A100 :100 V AC A120 :120 V AC A200 :200 V AC A240 :240 V AC	None: Terminal Box N:DIN Plug-in Connector (Optional)	A: Single B: Combination (Single Operation Allowed)	00: Standard	12
ASR2		C	C : 16 MPa			D12 :12 V DC D48 :48 V DC D110 :110 V DC D200 :200 V DC D220 :220 V DC				12
ASR3		E*, G	H : 21 MPa			R100 :100 V AC R110 :110 V AC R200 :200 V AC R220 :220 V AC				12
ASR5		G, J				12				
ASR10		J, M				12				

*1. To order an AC servo motor driven pump separately for spare use, prefix "N-" to the model number and omit the Function Selection and Parameter Number.

Example) N-ASR3-4G-HXSA100N-12

*2. For the relationship between the power capacity and the pressure/flow in terms of specification limits, see charts on pages A-219 and A-220.

*3. When selecting the power capacity "E", only an input voltage of 200 V AC is available.

*4. Types shown in the shaded areas are optional. Check the delivery date before selecting them.

*5. This is applicable only when "W" is selected for flow setting.

*6. The following symbol is added the column of electrical wiring system of solenoid valves. (except for ASR2)

M : Terminal Box Type (without manual actuator)

P : Plug-in Connector Type (without manual actuator)

*7. For combination operation, consult us separately regarding the types of hydraulic circuits, components, and electric cables.

■ Solenoid Ratings

Please see the solenoid ratings on page A-51.

■ Pipe Flange Kit

No pipe flange kit is included with the pump. The pipe flange kits below are available if required. For the details of the pipe flange kits, see pages A-258 and A-259.

Pump Model Numbers	Name of Port	Pipe Flange Kit Numbers		
		Threaded Connection	Socket Welding*	Butt Welding
ASR1 ASR2	Suction	F5-06-A-10	F5-06-B-10	F5-06-C-10
	Discharge	F5-06-A-10	F5-06-B-10	F5-06-C-10
ASR3 ASR5	Suction	F5-10-A-10	F5-10-B-10	F5-10-C-10
	Discharge	F5-10-A-10	F5-10-B-10	F5-10-C-10
ASR10	Suction	F5-16-A-10	F5-16-B-10	F5-16-C-10
	Discharge	F5-10-A-10	F5-10-B-10	F5-10-C-10

★ For the socket welding type F5-06-B-10 or F5-10-B-10, the operating pressure may be limited due to the flange strength.

Characteristics of Single Displacement Type

Input Signal Voltage vs. Pressure

● ASR1/ASR3/ASR5/ASR10- ** -HX

● ASR2- * C-CX

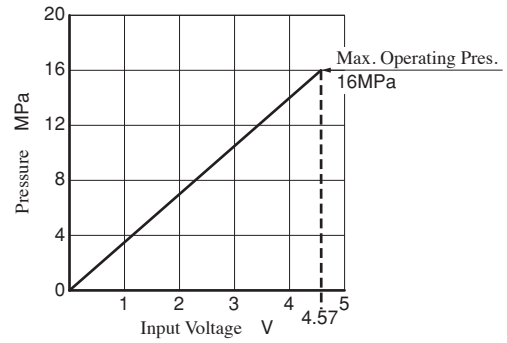
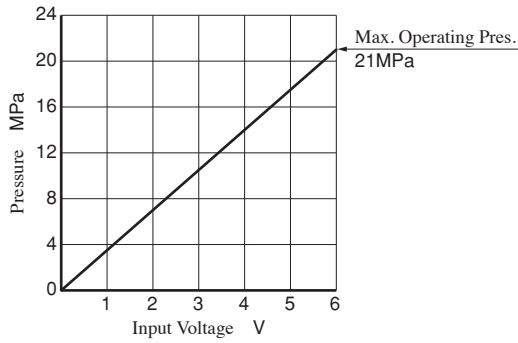

★ Do not input a voltage higher than the level corresponding to the maximum operating pressure.

Input Signal Voltage vs. Shaft Speed

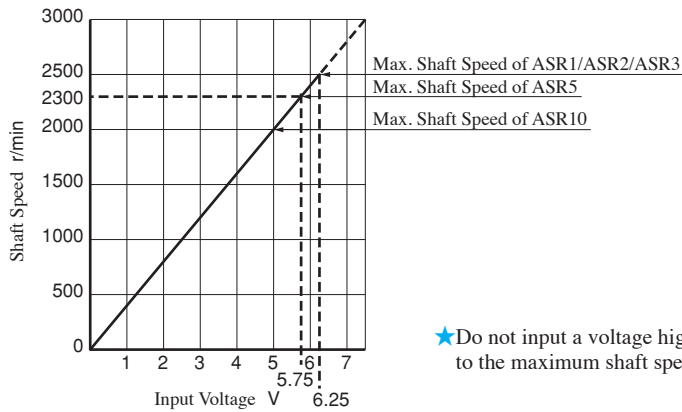

★ Do not input a voltage higher than the level corresponding to the maximum shaft speed.

Safety Valve Pressure Adjustment Screw Projection and Safety Valve Setting Pressure

● ASR1/ASR3/ASR5- ** -HX

● ASR2- * C-CX

● ASR10- ** -HX

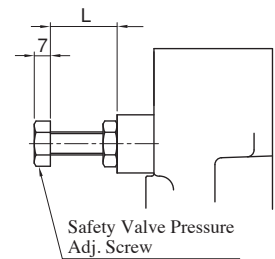
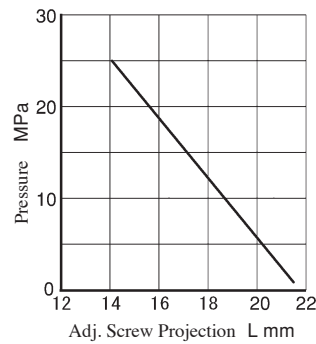
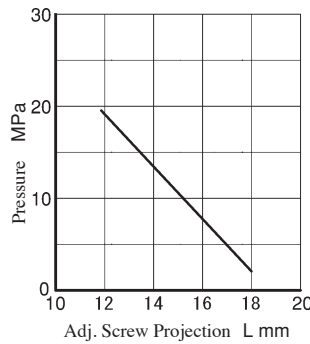
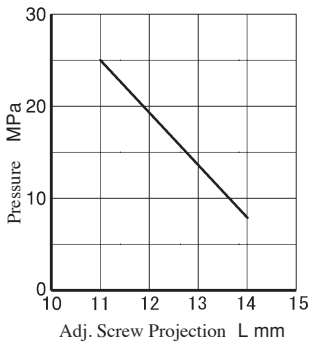

Flow Adjustment Screw Projection and Geometric Displacement

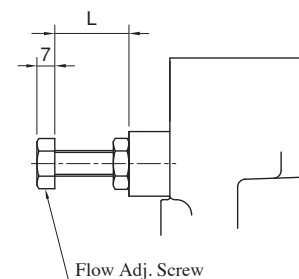
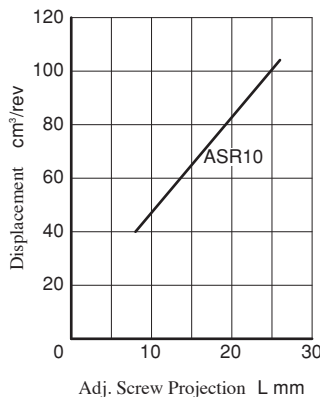
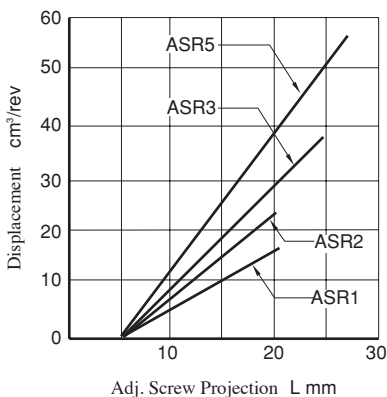

Characteristics of Dual Displacement Type

Input Signal Voltage vs. Pressure

See “Characteristics of Single Displacement Type” (page A-217).

Input Signal Voltage vs. Shaft Speed

See “Characteristics of Single Displacement Type” (page A-217).

Flow Adjustment Screw Projection and Geometric Displacement

Large Displacement Side Flow Adj. Screw (Check operation with the solenoid operated directional valve “off”.)

This is the same as the single displacement type. See “Characteristics of Single Displacement Type” (page A-217).

Note that the value cannot be set below the level set by the small displacement side adjustment screw.

Small Displacement Side Flow Adj. Screw (Check operation with the solenoid operated directional valve “on” and at a load pressure of 3 MPa or more.)

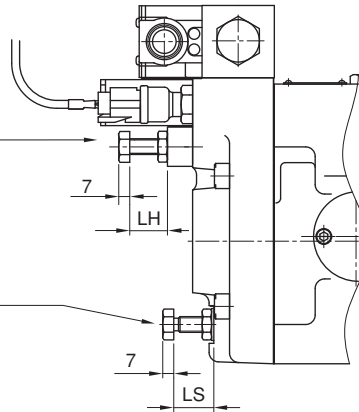

[Small Displacement]

● ASR1- *C-HW

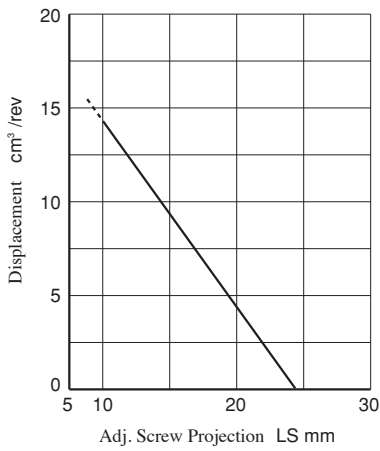

● ASR2- *C-CW

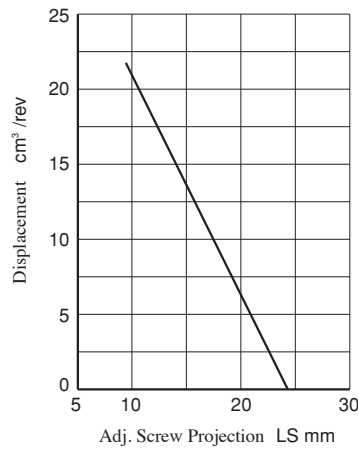

● ASR3- * *-HW

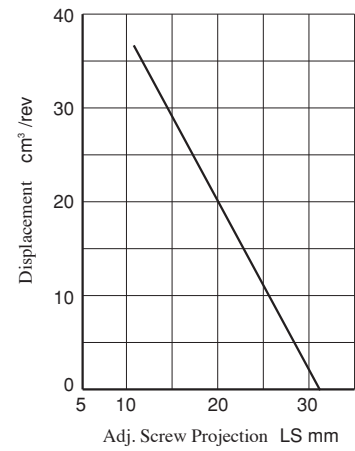

● ASR5- * *-HW

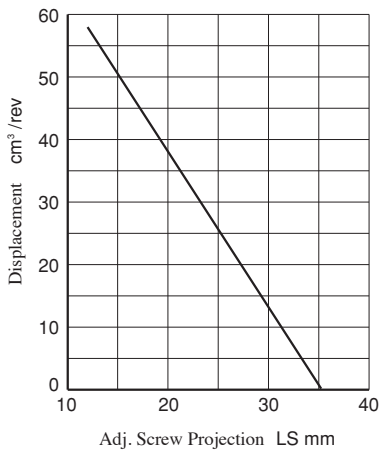

● ASR10- * *-HW

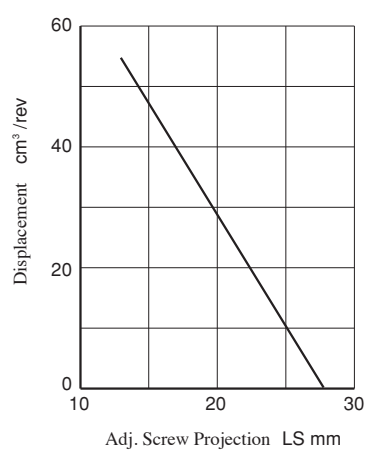

Pressure vs. Discharge Flow (Single Displacement Type "W")(Reference)

- Max Continuous Operation Time: 100 sec.
- Max Continuous Operation Time: 30 sec.

ASR1- *C-HX *

Maximum Displacement Range (15.8 cm³/rev)

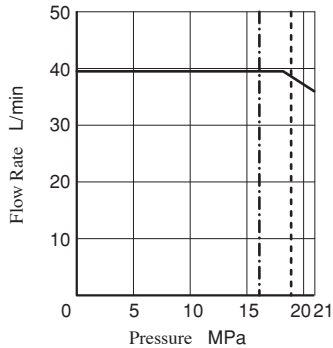

ASR2- *C-CX *

Maximum Displacement Range (22.2 cm³/rev)

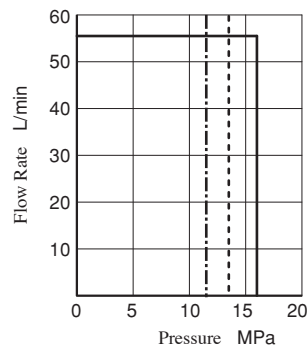

ASR3-E-HX *

Maximum Displacement Range (36.9 cm³/rev)

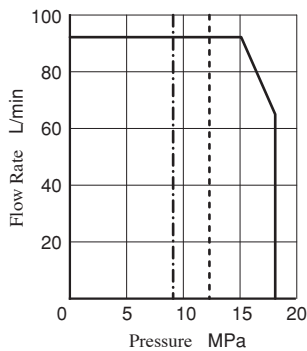

ASR3- *G-HX *

Maximum Displacement Range (36.9 cm³/rev)

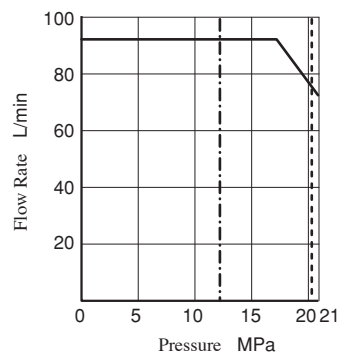

ASR5- *G-HX *

Maximum Displacement Range (56.2 cm³/rev)

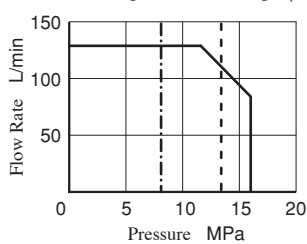

ASR5- *J-HX *

Maximum Displacement Range (56.2 cm³/rev)

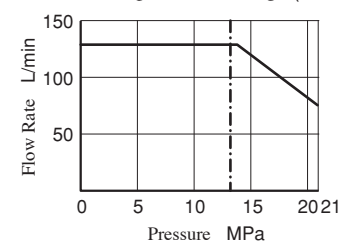

ASR10- *J-HX *

Maximum Displacement Range (100.0 cm³/rev)

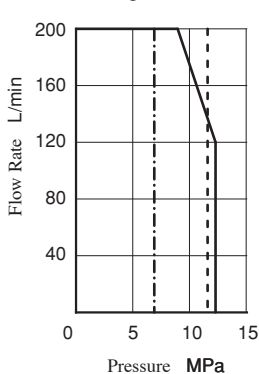

ASR10- *M-HX *

Maximum Displacement Range (100.0 cm³/rev)

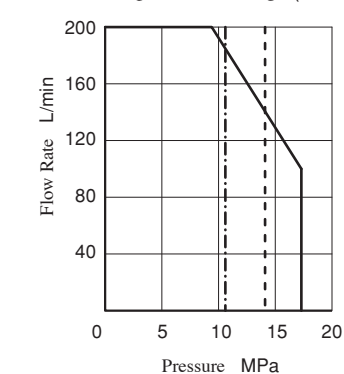

■ Pressure vs. Discharge Flow (Single Displacement Type “W”)(Reference)

- Large Displacement : Max. Continuous Operation Time : 100 sec.
- Large Displacement : Max. Continuous Operation Time : 30 sec.
- //// Small Displacement : Max. Continuous Operation Time

● ASR1- *C-HW *

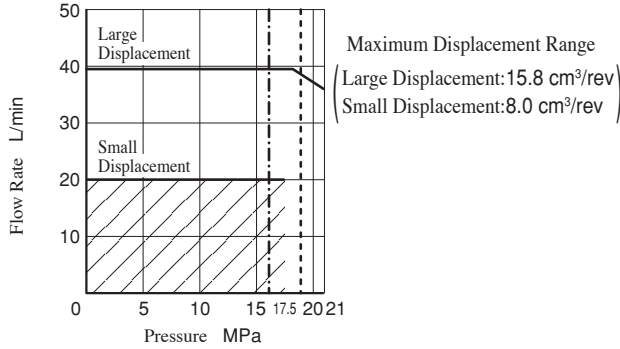

● ASR2- *C-CW *

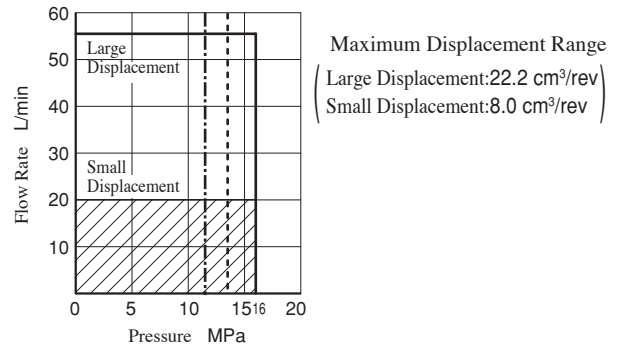

● ASR3-E-HW *

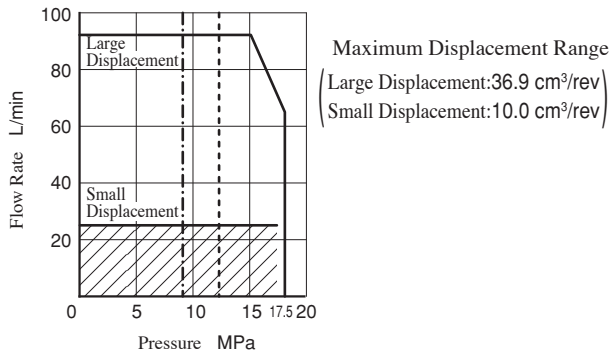

● ASR3- *G-HW *

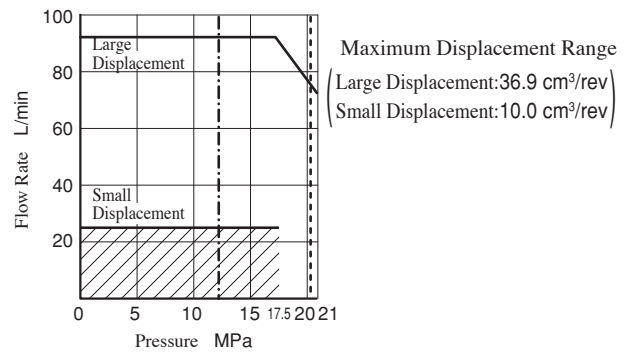

● ASR5- *G-HW *

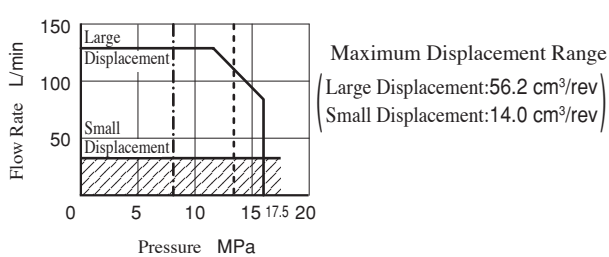

● ASR5- *J-HW *

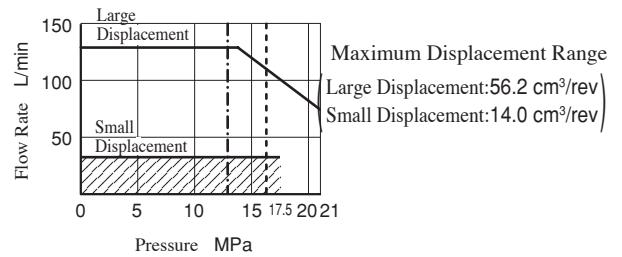

● ASR10- *J-HW *

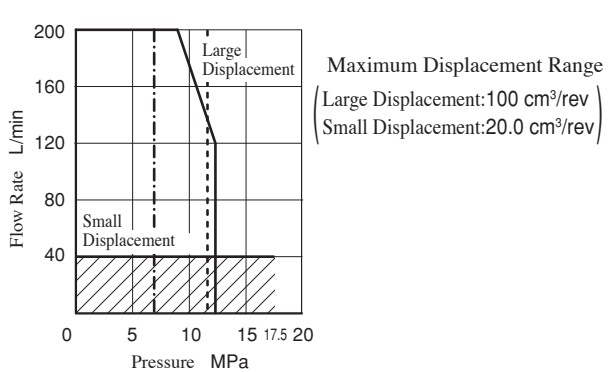

● ASR10- *M-HW *

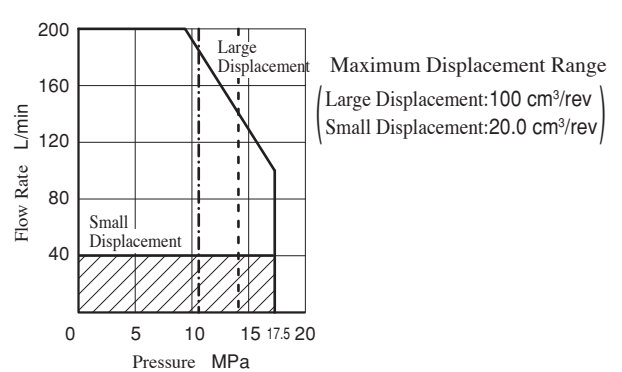

ASR1- * C-HXS- (Side Port Type) ASR2- * C-CXS-

Single Displacement Type

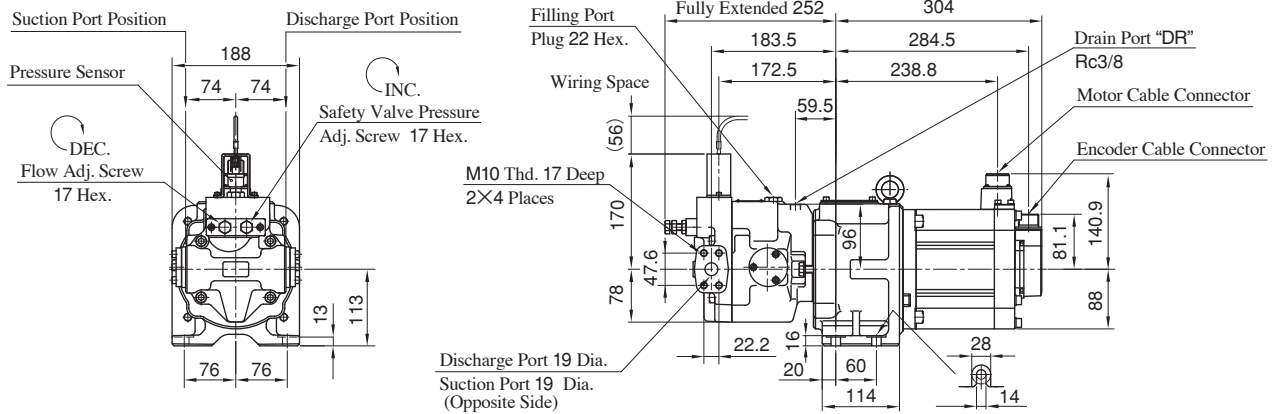

ASR1- * C-HX- (Axial Port Type) ASR2- * C-CX-

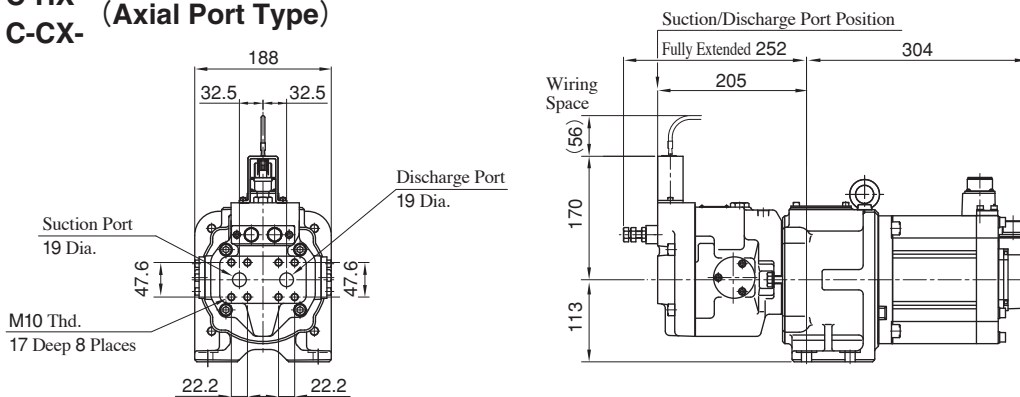

● For other dimensions, see the figure for the side port type.

ASR1- * C-HWS- (Side Port Type) ASR2- * C-CWS-

Dual Displacement Type

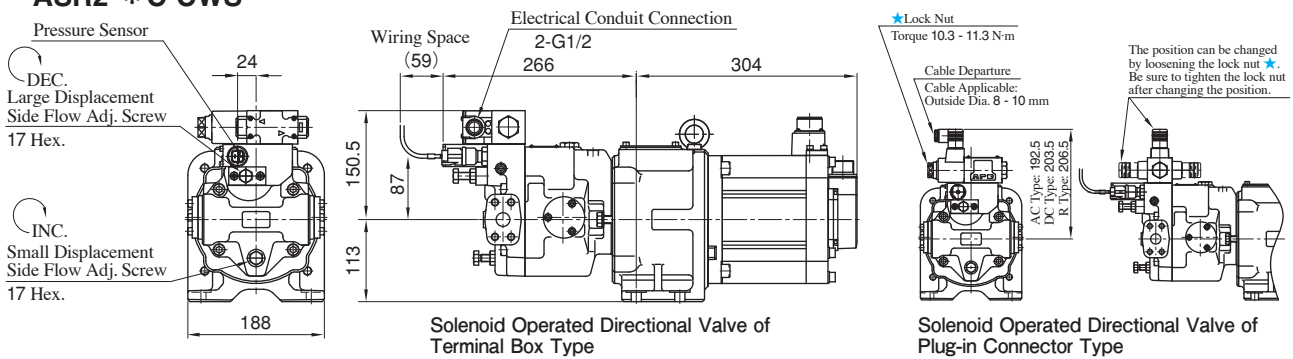

● For other dimensions, see the figure for the single displacement type.

ASR1- * C-HW- (Axial Port Type) ASR2- * C-CW-

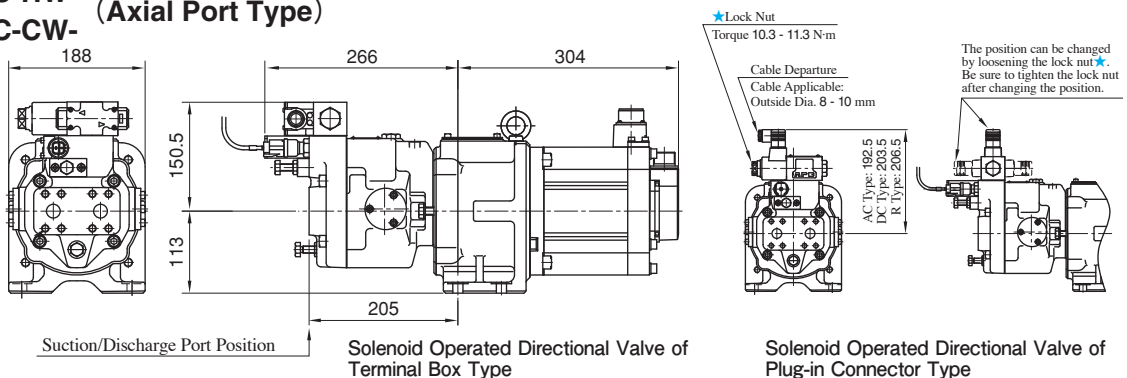

● For other dimensions, see the figure for the single displacement type.

ASR3-**-HXS- (Side Port Type)

Single Displacement Type

Model Numbers	A	B	C	D
ASR3-E-H*S-	364	344.5	290.8	149.1
ASR3-*G-H*S-	404	384.5	330.8	149.1

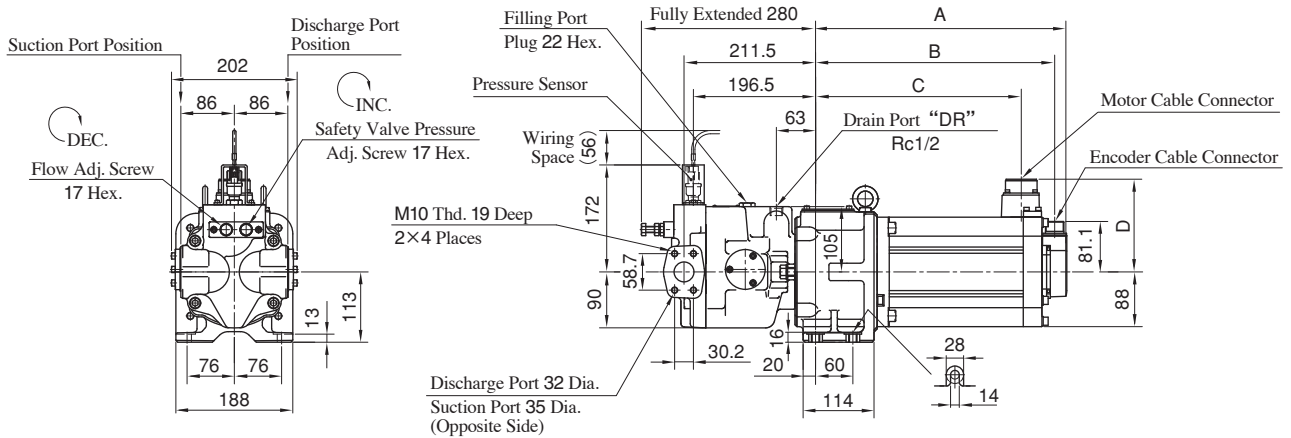

ASR3-**-HX- (Axial Port Type)

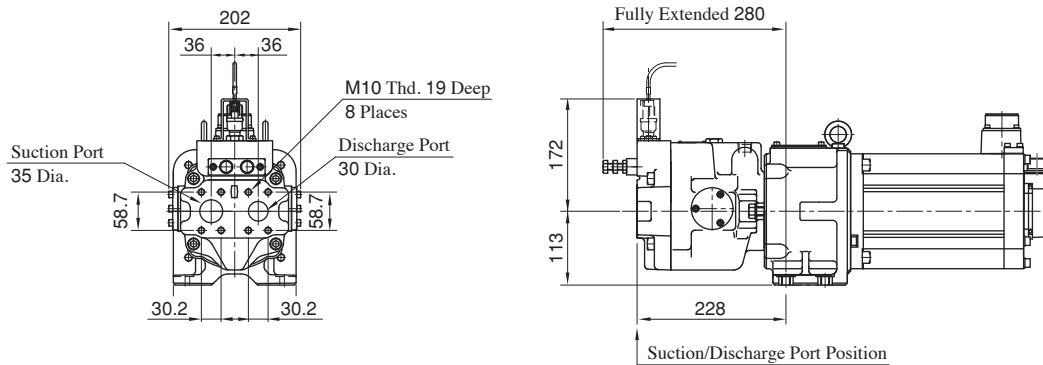

● For other dimensions, see the figure for the side port type.

ASR3-**-HWS- (Side Port Type)

Dual Displacement Type

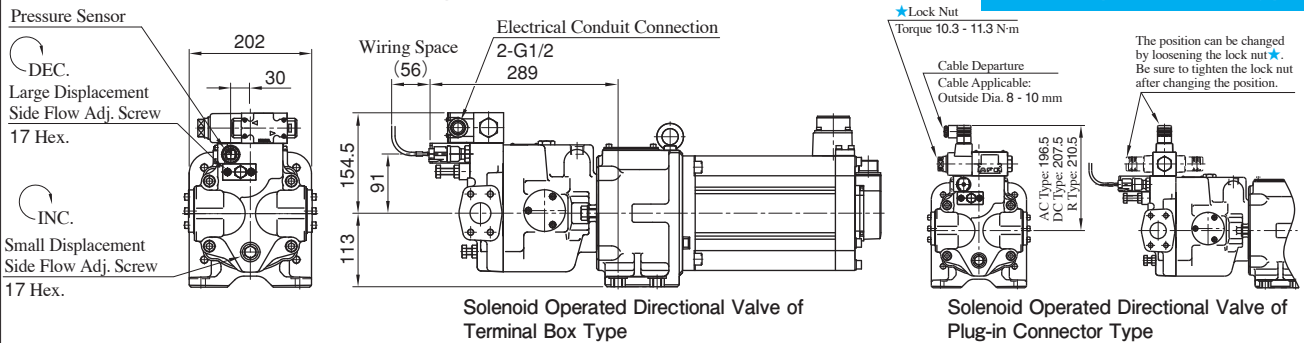

● For other dimensions, see the figure for the single displacement type.

ASR3-**-HW- (Axial Port Type)

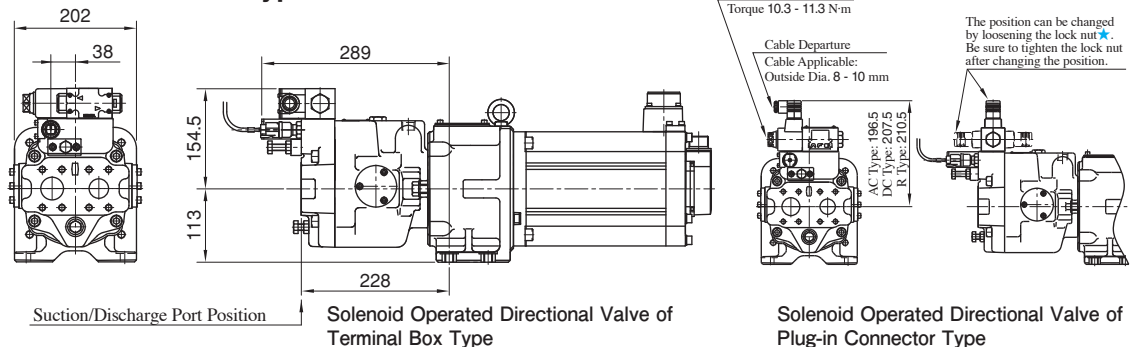

● For other dimensions, see the figures for the single displacement type and the dual displacement side port type.

ASR5- *G-HXS- (Side Port Type)

Single Displacement Type

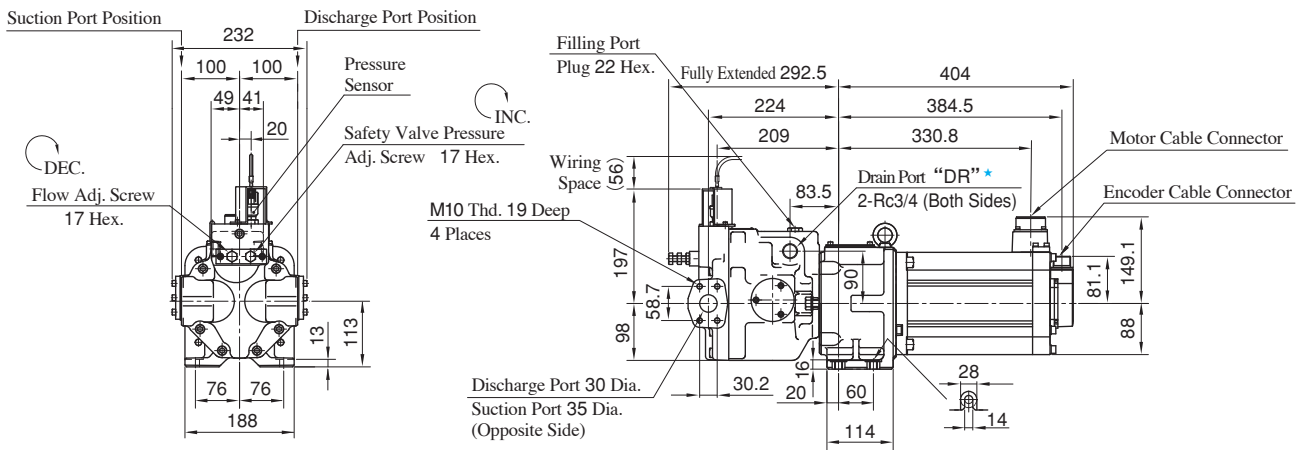

★Use either of two drain ports at your option. Keep the unused port plugged.

ASR5- *G-HX- (Axial Port Type)

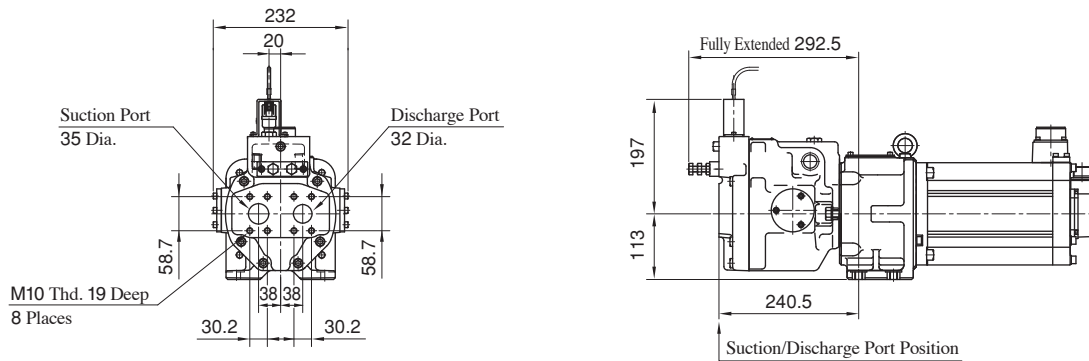

ASR5- *G-HWS- (Side Port Type)

Dual Displacement Type

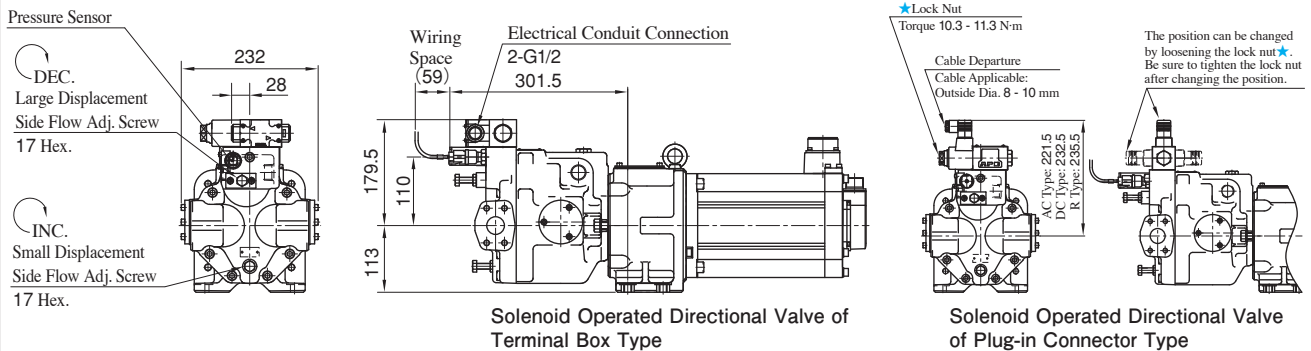

● For other dimensions, see the figure for the single displacement type.

ASR5- *G-HW- (Axial Port Type)

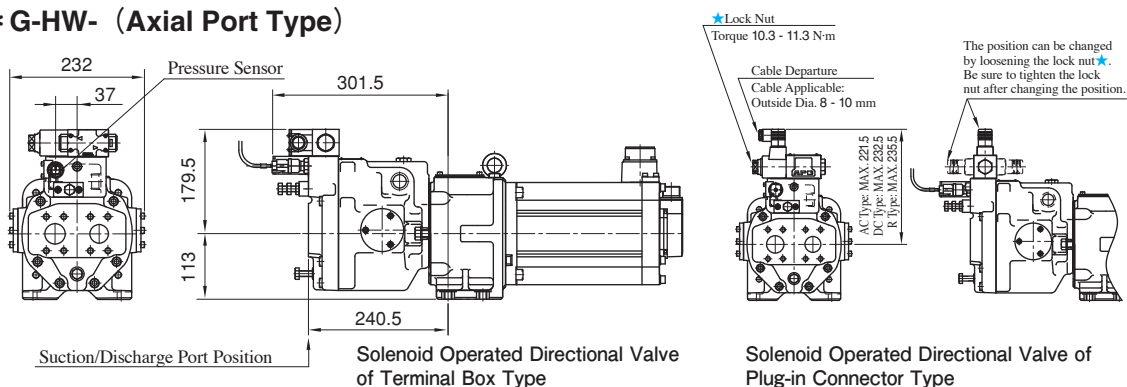

● For other dimensions, see the figures for the single displacement type and the dual displacement side port type.

ASR5- * J-HXS- (Side Port Type)

Single Displacement Type

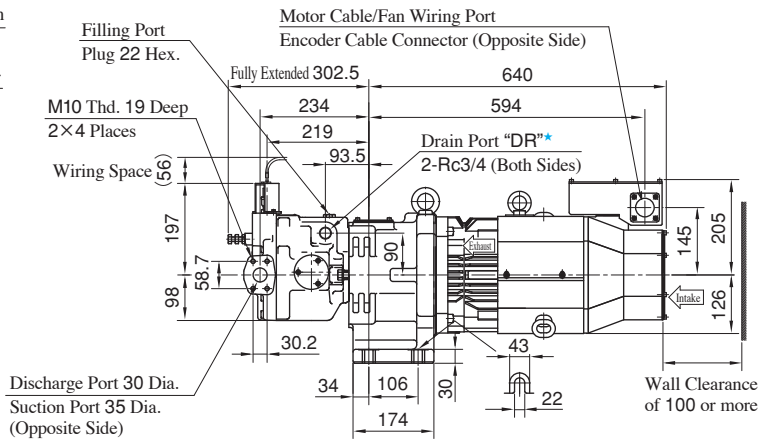
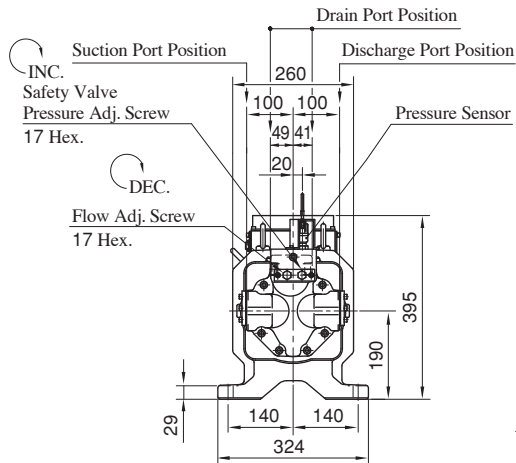

★ Use either of two drain ports at your option. Keep the unused port plugged.

ASR5- * J-HX- (Axial Port Type)

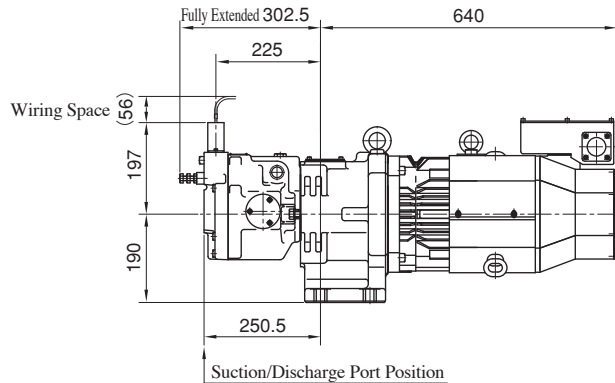
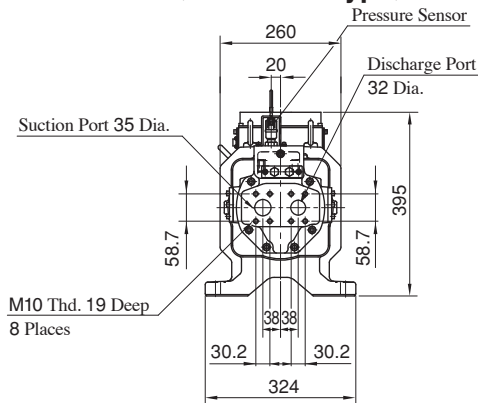

● For other dimensions, see the figure for the side port type.

ASR5- * J-HWS- (Side Port Type)

Dual Displacement Type

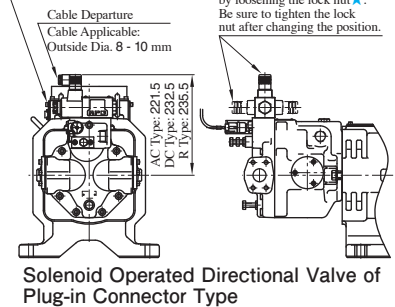
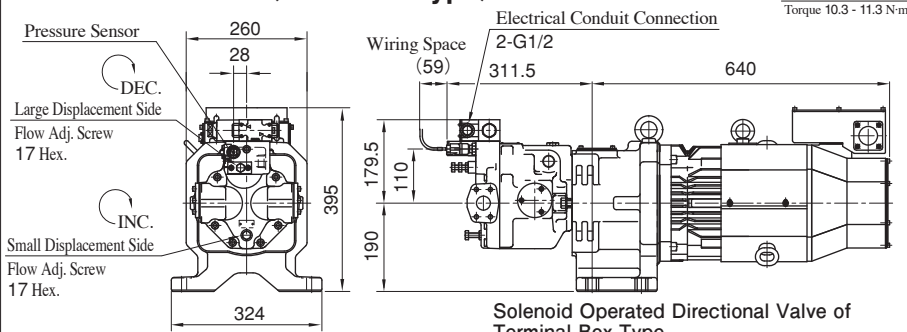

● For other dimensions, see the figure for the single displacement type.

ASR5- * J-HW- (Axial Port Type)

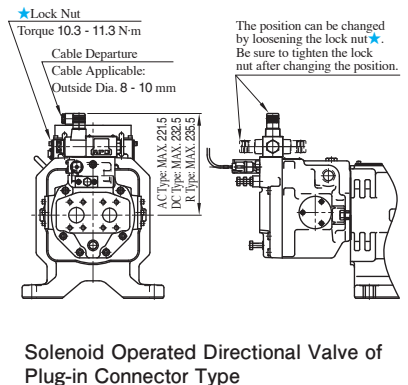
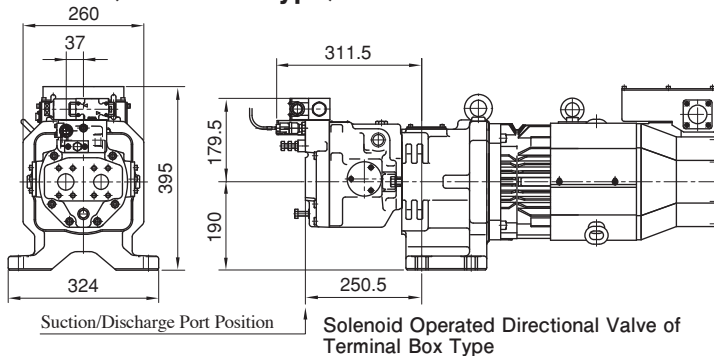

● For other dimensions, see the figures for the single displacement type and the dual displacement side port type.

ASR10-**-HXA- (Horizontal Type)

Single Displacement Type

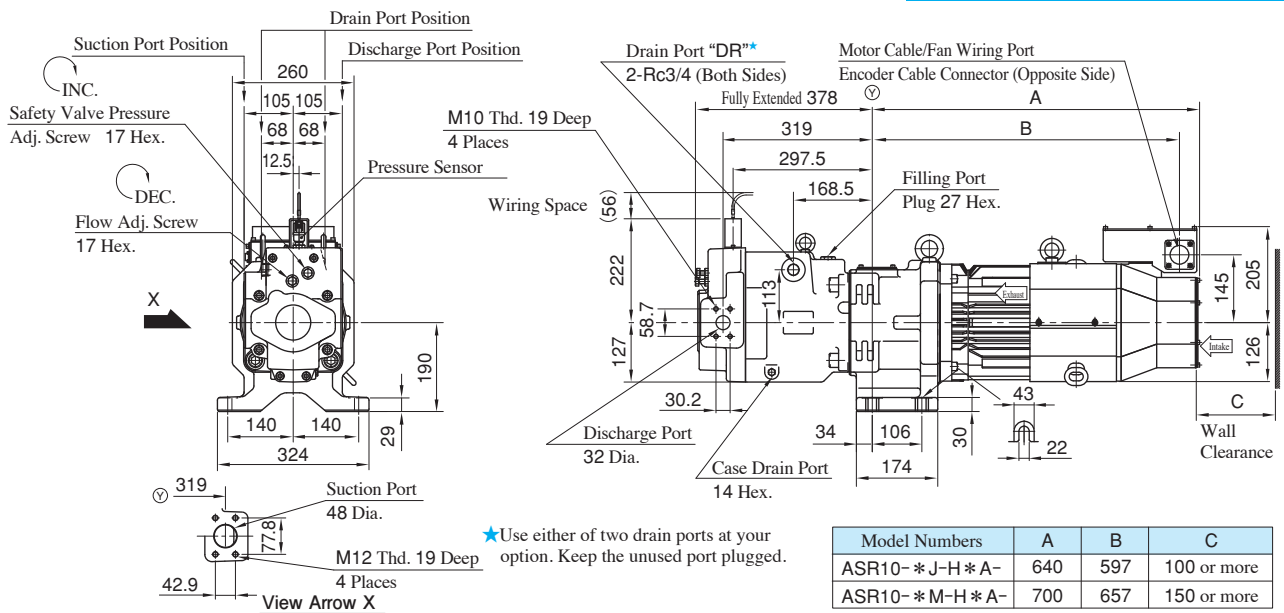

ASR10-**-HXB- (Vertical Type)

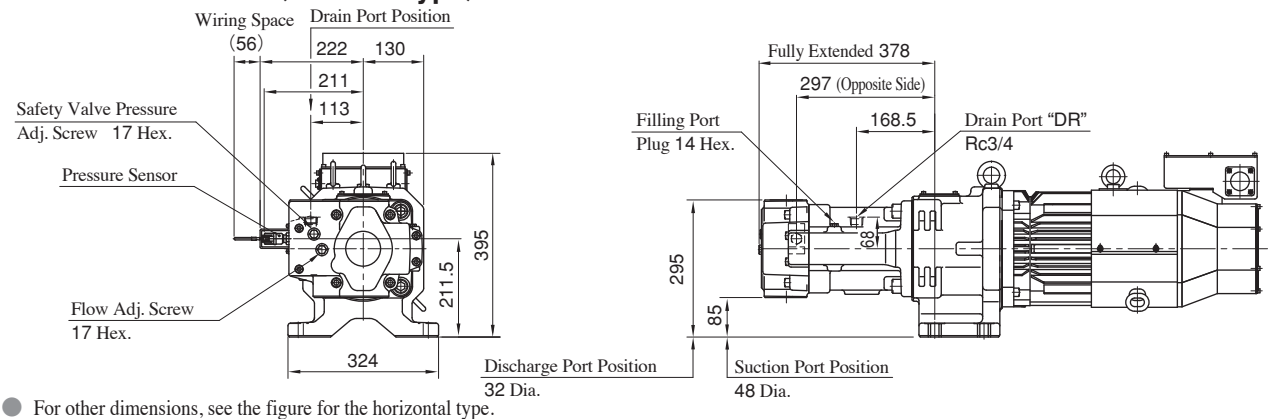

ASR10-**-HWA- (Horizontal Type)

● For other dimensions, see the figure for the single displacement type.

Dual Displacement Type

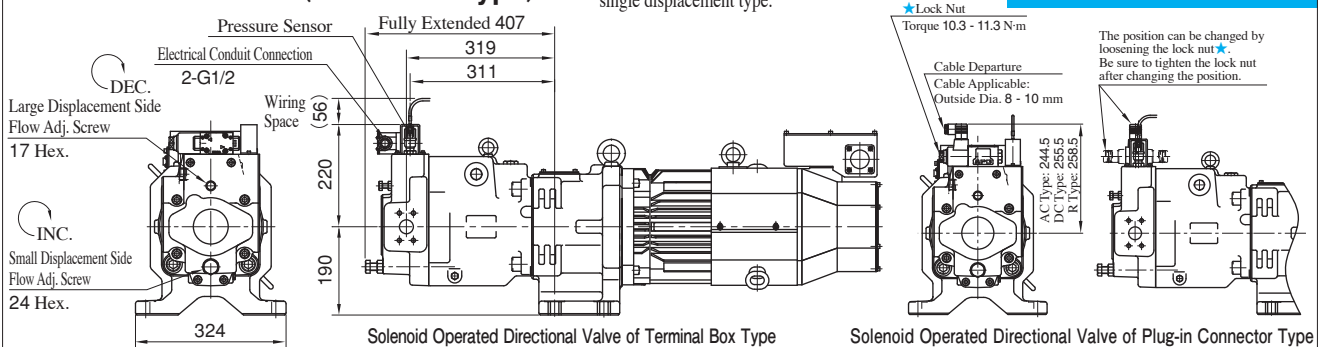

ASR10-**-HWB- (Vertical Type)

● For other dimensions, see the figures for the single displacement type and the dual displacement horizontal type.

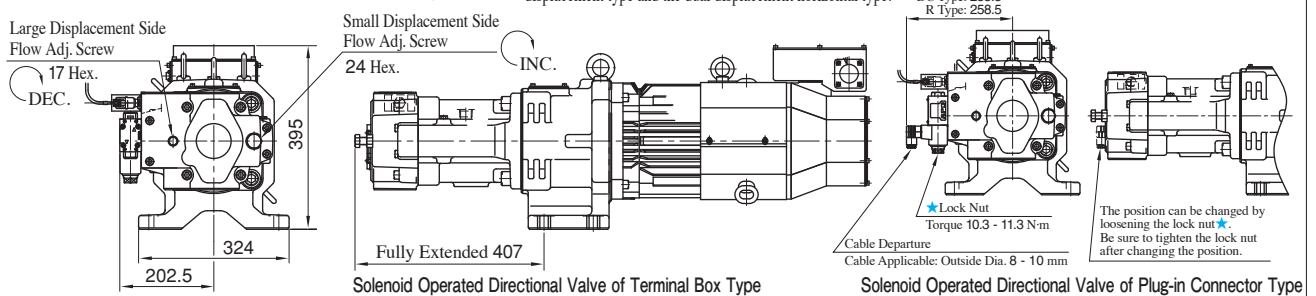

AMSR Controller

The AMSR controller is used to drive ASR series AC servo motor driven pumps. With an optimal design for the ASR pumps, the controller can maximize the pump performance. The AMSR controller is included with the ASR series pumps.



Specifications

Model Numbers		AMSR- *C- *00-10	AMSR-2DE- *00-10	AMSR- *FGI- *00-10	AMSR- *HJL- *00-10	AMSR- *KMO- *00-10
Control Unit Specifications	Command Signal Input Voltage	0 - +10 V DC				
	Command Signal Input Impedance	10 kΩ				
	Monitor Output Voltage	0 - +10 V DC				
	Sequence Input Signal	Photocoupler Input 8ch				
	Sequence Output Signal	Open Collector Output 6ch				
Main Circuit Power	Voltage/Frequency	200 V	200 to 230 V AC, 50/60 Hz, 3-Phase			
		400 V	380 to 480 V AC, 50/60 Hz, 3-Phase			
	Permissible Voltage Fluctuation	200 V	170 to 253 V AC, 3-Phase			
		400 V	323 to 528 V AC, 3-Phase			
Permissible Frequency Fluctuation	Within ±5%					
Power Supply Capacity		6.8 kVA	8.6 kVA	12 kVA	16 kVA	22 kVA
Regeneration Resister (Dynamic Brake)		Built-in		External Option		
Cooling System		Fan-cooling, Open (IP 00)				
Environmental Condition	Ambient Temperature	0 - +50 °C (No Freezing)				
	Ambient Humidity	90 %RH or less (No Condensation)				
Protective Functions		<ul style="list-style-type: none"> Overcurrent Shutdown Servo Motor Overheat Protection Undervoltage Protection Excess Error Protection 	<ul style="list-style-type: none"> Regenerative Overvoltage Shutdown Encoder Malfunction Protection Instantaneous Power Failure Protection 	<ul style="list-style-type: none"> Overload Shutdown Regeneration Malfunction Protection Overspeed Protection 		
Mass kg		4.6	6.2	18		19
Applicable Pump		ASR1- *C ASR2- *C	ASR3-E	ASR3- *G ASR5- *G	ASR5- *J ASR10- *J	ASR10- *M

Model Number Designation

AMSR	-2	C	-A	00	-10
Series Numbers	Power Supply Voltage	Amplifier Capacity kW	Function Selection	Parameter Number	Design Number
AMSR : AMSR Controller	2 : 200 V AC	DE : 7.0	A : Single B : Combination (Single Operation Allowed)	00 : Standard	10
	2 : 200 V AC	C : 5.0 FGI : 11.0 HJL : 15.0 KMO : 22.0			
	4 : 400 V AC				

AMSR- * C- * 00-10

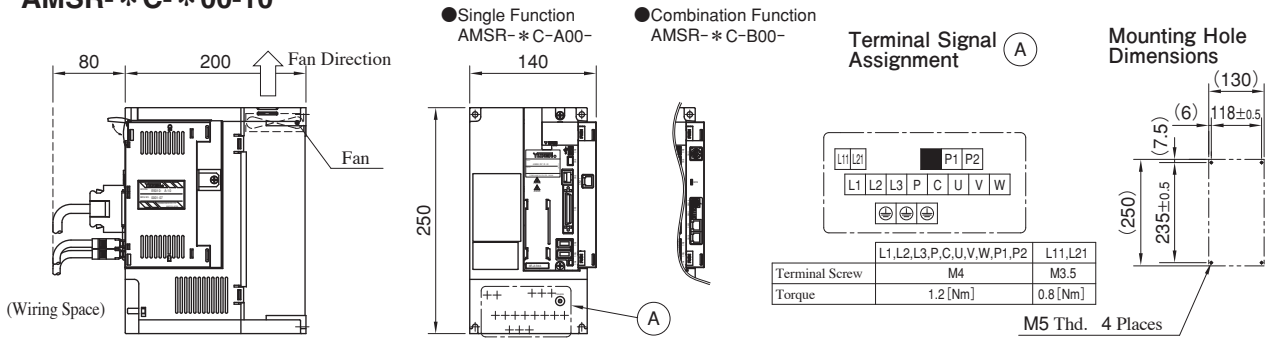

AMSR-2DE- * 00-10

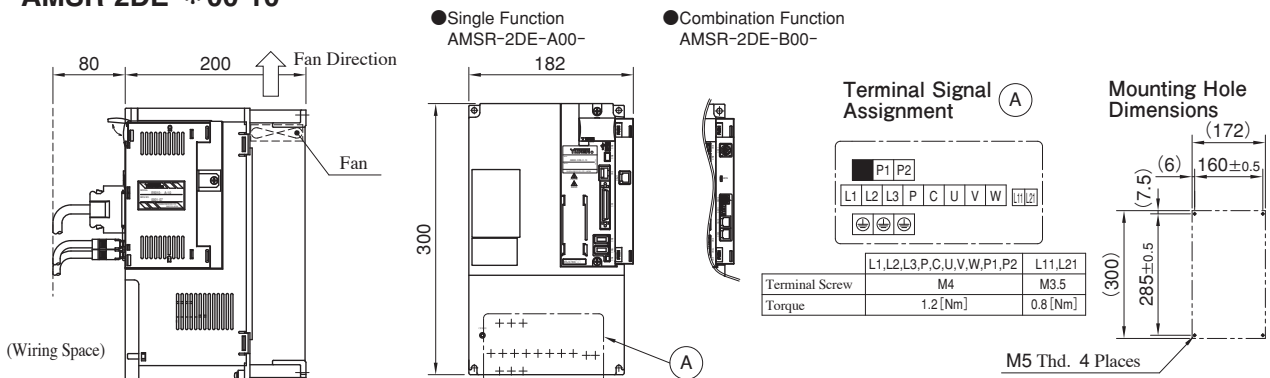

AMSR- * FGI/ * HJL/ * KMO- * 00-10

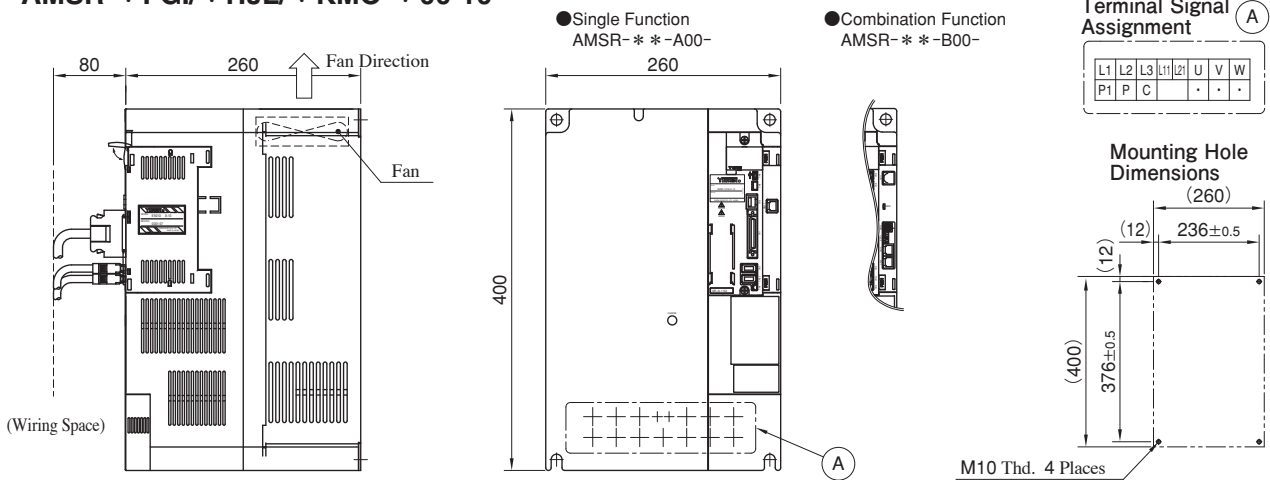

Terminal Symbol	L1-L3, U, V, W, P1, P, C	L11, L12
Terminal Screw Size/ Torque	AMSR- * FGI/ * HJL- * 00-10 AMSR- * KMO- * 00-10	M4/1.2

Installation Standard

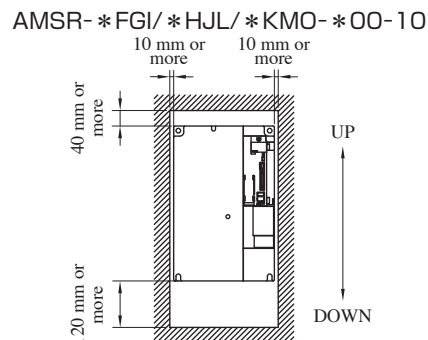
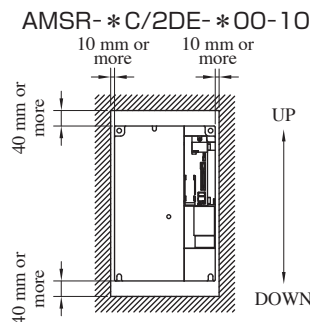

★ Consult us when installing multiple controllers next to each other.

Terminal Names/Appearance

AMSR- * C-A00- Single Function

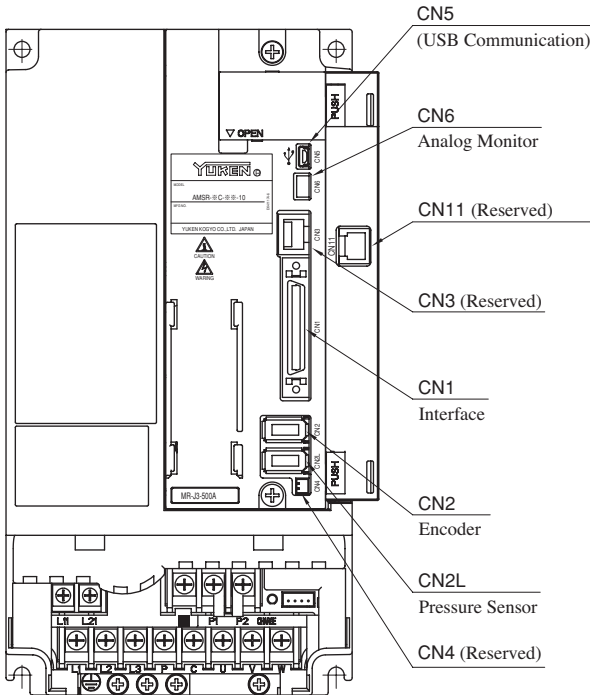

AMSR- * C-B00- Combination Function

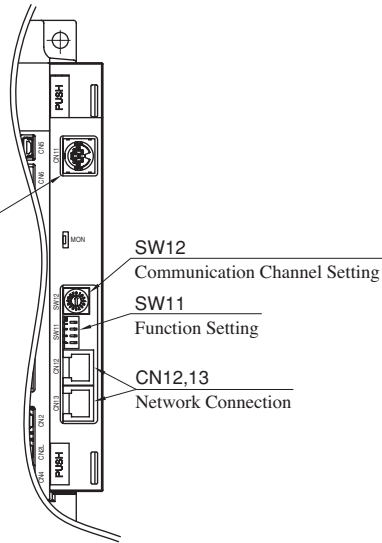

AMSR-2DE-

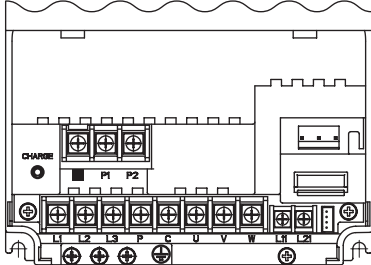

AMSR- * FGI/ * HJL/ * KMO-

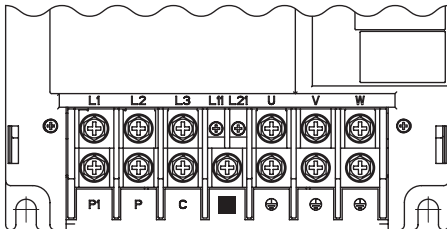

Function	Symbol	Terminal Name	Terminal Channel	Description
Single/ Combination	CN5	USB Communication	—	With the USB communication function, servo operation, parameter change, and monitor function can be performed on a PC. Recommended Cable USB Cable: Mini B Type
			1	For the manufacturer's setting. : Always OFF.
Combination	SW11	Function Selection	2	Reserved.
			3	For switching single and combination operations. OFF: Combination, ON: Single
			4	For network termination setting. OFF: None, ON: 150 Ω
	SW12	Communication Channel Selection	0	Master station
			1~F	Slave station
	CN12, CN13	Network Connection	—	For connection to the network based on the AMSR controller. Recommended Cable TFL-FST- * S (SANWA) MJ-FS * (ELECOM)

Terminal Block

Connection (Use)	Signal Name	Description	
		AMSR-2C/2DE/ 2FGI/2HJL/2KMO	AMSR-4C/4FGI/ 4HJL/4KMO
DC Reactor for Power Factor Improvement	P1	P1 - P2 is short-circuited by default (the DC reactor cannot be used).★1	
	P2		
Regenerative Converter Brake Unit	N	Not connected.★1	

★1 Contact us when connecting the units.

For the details of CN1, CN2L, and CN6, consult us separately.

Wire Connection Diagram

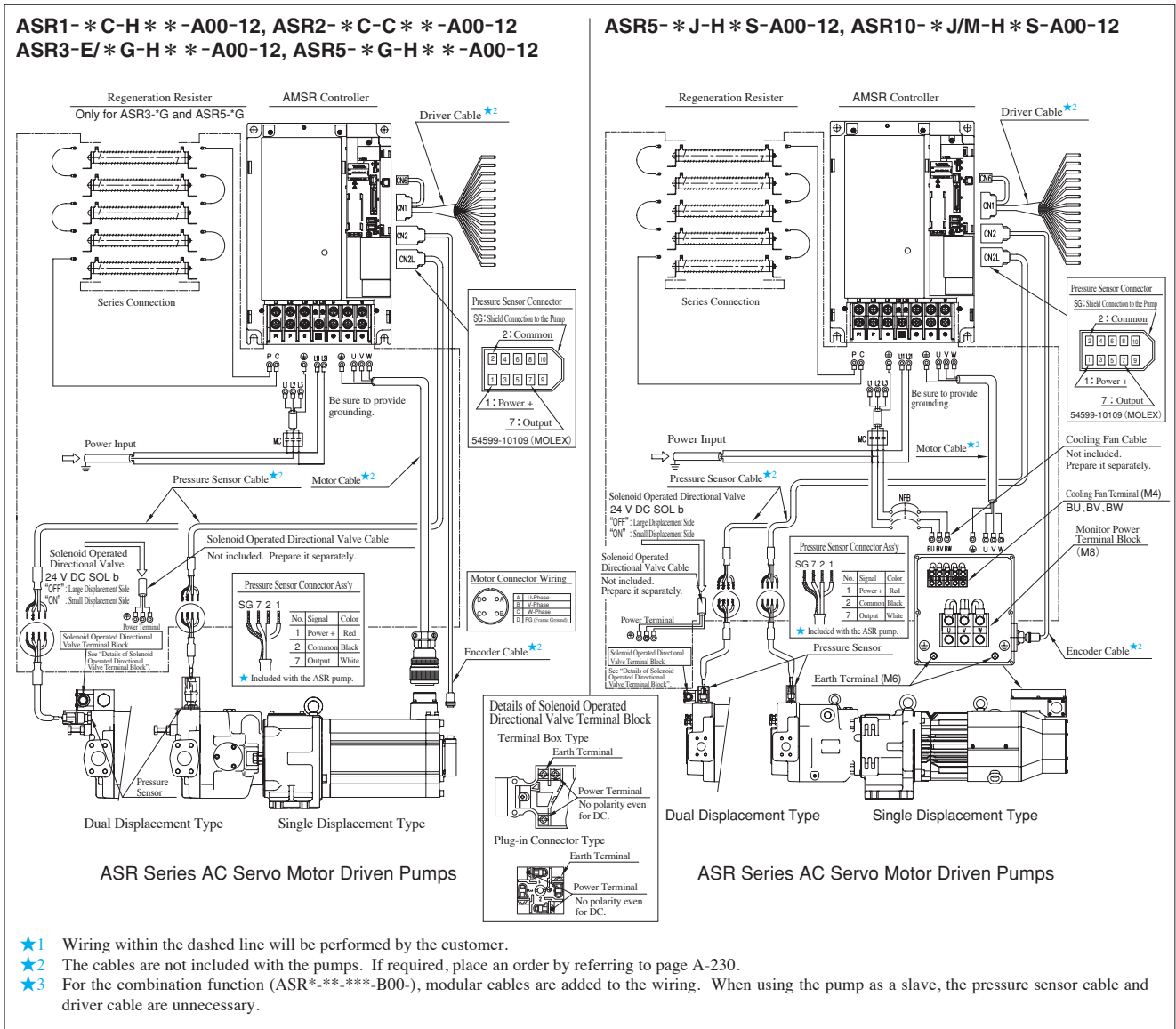

Connectors

	CN1	CN2L	CN6
Housing	10150-3000VE(3M)	54599-1019 (MOLEX)	51004-0300 (MOLEX)
Terminal	-----		-----
Case	10350-52F0-008(3M)		50011-8100 (MOLEX)
Cable	Core Size	AWG # 24 - # 30	AWG # 24 - # 34
	Covered Dia.	1.2-1.5 Dia.	0.8-1.4 Dia.
	Strip Length	2.0-2.5mm	1.2-2.0mm

Motor Cable Plug/Cable Clamp

Model Numbers	Motor Cable Plug		Cable Clamp
	Straight	L-shaped	
ASR 1/ASR 2	MS3106B22-22S	MS3108B22-22S	MS3057-12A
ASR 3- *G	MS3106B32-17S	MS3108B32-17S	MS3057-20A

DDK Ltd.

Wiring Types

Common Wiring

Terminals and Cables	Wiring mm ²
L11 · L21	1.25 (AWG16) *
Pressure Sensor Cable	0.5 (AWG20)

Regeneration Resistor Wiring : 5.5mm² (AWG10) *

Power Classification

Electric Source	Model Numbers	Wiring mm ²	
		Power Input L1, L2, L3 *	Motor Cable U, V, W *
200 V AC 3-Phase	ASR1/ASR2/ASR3-C	5.5 (AWG10)	5.5 (AWG10)
	ASR3-E	8 (AWG8)	8 (AWG8)
	ASR3/ASR5-G	14 (AWG6)	22 (AWG4)
	ASR5/ASR10-J	22 (AWG4)	22 (AWG4)
	ASR10-M	50 (AWG1/0)	30 (AWG2)
400 V AC 3-Phase	ASR1/ASR2/ASR3-4C	5.5 (AWG10)	5.5 (AWG10)
	ASR3/ASR5-4G	8 (AWG8)	8 (AWG8)
	ASR5/ASR10-4J	14 (AWG6)	8 (AWG8)
	ASR10-4M	14 (AWG6)	22 (AWG4)

* Use a 600 V vinyl-insulated cable.

Cable Numbers

The cables are not included with the ASR pumps. If required, place an order by referring to the list below. The cables other than the motor cable are common for all models.

Motor Cable

ASR Pump Model Numbers	Cable Model Numbers	Remarks
ASR 1-*C-H* *- *00-12	YSDC-M1-29-☆-★-10	☆ : Plug Type S : Straight, L : L-shaped ★ : Cable Length 03 : 3 m 05 : 5 m 10 : 10 m 15 : 15 m 20 : 20 m 30 : 30 m N : Plug and cable clamp only
ASR 2-*C-C* *- *00-12		
ASR 3-E-H* *- *00-12	YSDC-M1-44S-☆-★-10	
ASR 3-G-H* *- *00-12	YSDC-M1-1A-☆-★-10	
ASR 3-4G-H* *- *00-12	YSDC-M1-44S-☆-★-10	
ASR 5-G-H* *- *00-12	YSDC-M1-1A-☆-★-10	
ASR 5-4G-H* *- *00-12	YSDC-M1-44S-☆-★-10	

Driver Cable/Encoder Cable/Pressure Sensor Cable

Cable Type	Cable Model Numbers	Remarks
Driver Cable	YSDC-D14-00-★-10	★ : Cable Length 01 : 1 m 02 : 2 m 03 : 3 m 05 : 5 m 10 : 10 m 20 : 20 m
Encoder Cable	YSDC-E7-S-★-10	★ : Cable Length 02 : 2 m 05 : 5 m 10 : 10 m
Pressure Sensor Cable	Consult us separately.	

Regeneration Resister

Specifications

AMSR Controller Model Numbers	Regeneration Resister Model	Qty.	Permissible Regeneration W	Regeneration with Fan W	Resistance Ω	Mass kg
AMSR-2FGI-	GRZG400-1.5 Ω	4	500	800	6 (1.5 Ω ×4)	3.2 (0.8kg×4)
AMSR-2HJL-	GRZG400-0.9 Ω	5	850	1300	4.5 (0.9 Ω ×5)	4.0 (0.8kg×5)
AMSR-2KMO-	GRZG400-0.6 Ω				3 (0.6 Ω ×5)	
AMSR-4FGI-	GRZG400-5.0 Ω	4	500	800	20 (5.0 Ω ×4)	3.2 (0.8kg×4)
AMSR-4HJL-	GRZG400-2.5 Ω	5	850	1300	12.5 (2.5 Ω ×5)	4.0 (0.8kg×5)
AMSR-4KMO-	GRZG400-2.0 Ω				10 (2.0 Ω ×5)	

★1. Regeneration Resistors are included with the ASR pumps.

★2. Regeneration Resistors may become excessively heated. Use heat-resistant and fireproof wires and avoid their contact with the brakes.

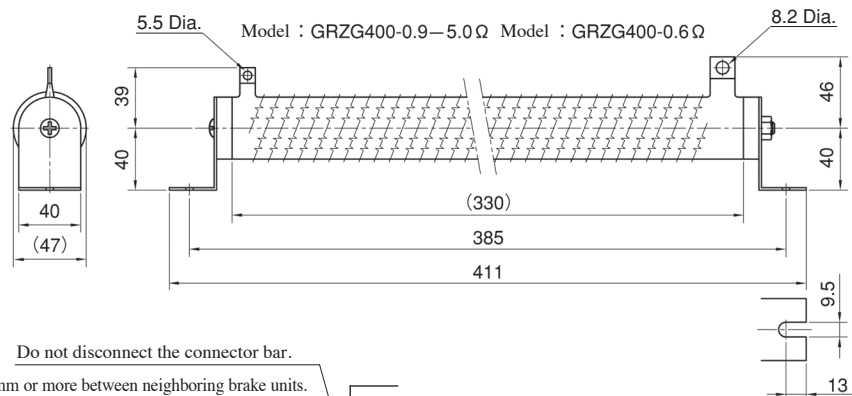

Connection

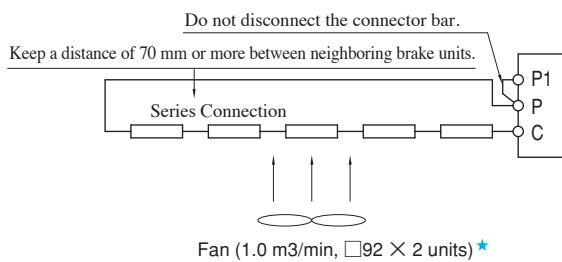

★Recommended fan capacity for fan cooling. In this case, change the setting of parameter No. PA02 from "0000" to "00FA".

По вопросам продаж и поддержки обращайтесь:

Алматы (7273)495-231
Ангарск (3955)60-70-56
Архангельск (8182)63-90-72
Астрахань (8512)99-46-04
Барнаул (3852)73-04-60
Белгород (4722)40-23-64
Благовещенск (4162)22-76-07
Брянск (4832)59-03-52
Владивосток (423)249-28-31
Владикавказ (8672)28-90-48
Владимир (4922)49-43-18
Волгоград (844)278-03-48
Вологда (8172)26-41-59
Воронеж (473)204-51-73
Екатеринбург (343)384-55-89
Иваново (4932)77-34-06
Ижевск (3412)26-03-58
Иркутск (395)279-98-46
Казань (843)206-01-48

Калининград (4012)72-03-81
Калуга (4842)92-23-67
Кемерово (3842)65-04-62
Киров (8332)68-02-04
Коломна (4966)23-41-49
Кострома (4942)77-07-48
Краснодар (861)203-40-90
Красноярск (391)204-63-61
Курган (3522)50-90-47
Курск (4712)77-13-04
Липецк (4742)52-20-81
Магнитогорск (3519)55-03-13
Москва (495)268-04-70
Мурманск (8152)59-64-93
Набережные Челны (8552)20-53-41
Нижний Новгород (831)429-08-12
Новокузнецк (3843)20-46-81
Новосибирск (383)227-86-73
Ноябрьск (3496)41-32-12

Омск (3812)21-46-40
Орел (4862)44-53-42
Оренбург (3532)37-68-04
Пенза (8412)22-31-16
Пермь (342)205-81-47
Петрозаводск (8142)55-98-37
Псков (8112)59-10-37
Ростов-на-Дону (863)308-18-15
Рязань (4912)46-61-64
Самара (846)206-03-16
Санкт-Петербург (812)309-46-40
Саранск (8342)22-96-24
Саратов (845)249-38-78
Севастополь (8692)22-31-93
Симферополь (3652)67-13-56
Смоленск (4812)29-41-54
Сочи (862)225-72-31
Ставрополь (8652)20-65-13
Сургут (3462)77-98-35

Сыктывкар (8212)25-95-17
Тамбов (4752)50-40-97
Тверь (4822)63-31-35
Тольятти (8482)63-91-07
Томск (3822)98-41-53
Тула (4872)33-79-87
Тюмень (3452)66-21-18
Улан-Удэ (3012)59-97-51
Ульяновск (8422)24-23-59
Уфа (347)229-48-12
Хабаровск (4212)92-98-04
Чебоксары (8352)28-53-07
Челябинск (351)202-03-61
Череповец (8202)49-02-64
Чита (3022)38-34-83
Якутск (4112)23-90-97
Ярославль (4852)69-52-93

Россия +7(495)268-04-70

Казахстан +7(7172)727-132

Киргизия +996(312)96-26-47

yne@nt-rt.ru || <https://yuken.nt-rt.ru>