

Power Packages

YUKEN's Power Packages have compactly integrated with compact high pressure vane pump, relief valve and oil tank etc., also be able to built-in O1 series solenoid operated directional valve (or manually operated directional valve) and modular valve.

It is easy to construct hydraulic circuit only by stacking solenoid operated valves and modular valves, so widely applicable as for compact hydraulic unit. There are two types of drive system, one is the pulley drive type with flow adjustment and another is the motor drive type (motor built-in type).

Features

- Because of using YUKEN vane pumps with good reputation, so that achieved good performance and long life.
- Only by adding or changing modular valves stacked on the power package, it is able to add or change hydraulic circuit easily and quickly.
- Can use immediately after hydraulic piping between the power package and actuators.

Motor Drive Type



Pulley Drive Type with Flow Adjustment



Specifications

Type	Descriptions	Model Numbers	Geometric Displacement of Pump cm ³ /rev	Max. Operating Pres. MPa	Rotational Speed r/min		Reservoir Capacity L	Mass *2 kg
					Max.	Min.		
Motor Drive Type	This power package is driven at the voltage of 200/220 V AC. Suitable for using on cargo handling machine or general industrial machine, etc.	PMR2- 6	5.8	14	4000	500 (1000)*1	3.4	(1.5 kW×6P) 50 (2.2 kW×4P) 51.5
		PMR2- 8	8.0					
		PMR2-10	9.4					
		PMR2-12	12.2					
		PMR2-14	13.7					
		PMR2-17	16.6					
Pulley Drive Type with Flow Adjustment	This type is equipped with flow adjustment system that can keep discharge volume of the package stable regardless of increase or decrease of engine rotational speed, so that is suitable for using as power steering pump.	PPF2- 6	5.8	10.5	3000	2800	3.4	(With V1S Type Pulley) 11.4 (With V1 Type Pulley) 11.8
		PPF2- 8	8.0					
		PPF2-10	9.4					
		PPF2-12	12.2					
		PPF2-14	13.7					
		PPF2-17	16.6					

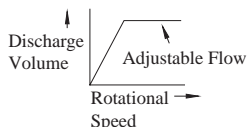

*1. Please set the minimum rotational speed on starting at the value in parenthesis.

*2. The values of mass are including hydraulic fluids in case of without control valves (circuit symbol "00"). In case of the mass with control valves, please add the additional mass of "standard circuit" on pages K-54 and K-55.

По вопросам продаж и поддержки обращайтесь:

Алматы (7273)495-231
Ангарск (3955)60-70-56
Архангельск (8182)63-90-72
Астрахань (8512)99-46-04
Барнаул (3852)73-04-60
Белгород (4722)40-23-64
Благовещенск (4162)22-76-07
Брянск (4832)59-03-52
Владивосток (423)249-28-31
Владикавказ (8672)28-90-48
Владимир (4922)49-43-18
Волгоград (844)278-03-48
Вологда (8172)26-41-59
Воронеж (473)204-51-73
Екатеринбург (343)384-55-89

Иваново (4932)77-34-06
Ижевск (3412)26-03-58
Иркутск (395)279-98-46
Казань (843)206-01-48
Калининград (4012)72-03-81
Калуга (4842)92-23-67
Кемерово (3842)65-04-62
Киров (8332)68-02-04
Коломна (4966)23-41-49
Кострома (4942)77-07-48
Краснодар (861)203-40-90
Красноярск (391)204-63-61
Курган (3522)50-90-47
Курск (4712)77-13-04
Липецк (4742)52-20-81

Магнитогорск (3519)55-03-13
Москва (495)268-04-70
Мурманск (8152)59-64-93
Набережные Челны (8552)20-53-41
Нижний Новгород (831)429-08-12
Новокузнецк (3843)20-46-81
Новосибирск (383)227-86-73
Ноябрьск (3496)41-32-12
Омск (3812)21-46-40
Орел (4862)44-53-42
Оренбург (3532)37-68-04
Пенза (8412)22-31-16
Пермь (342)205-81-47
Петрозаводск (8142)55-98-37
Псков (8112)59-10-37

Ростов-на-Дону (863)308-18-15
Рязань (4912)46-61-64
Самара (846)206-03-16
Санкт-Петербург (812)309-46-40
Саранск (8342)22-96-24
Саратов (845)249-38-78
Севастополь (8692)22-31-93
Симферополь (3652)67-13-56
Смоленск (4812)29-41-54
Сочи (862)225-72-31
Ставрополь (8652)20-65-13
Сургут (3462)77-98-35
Сыктывкар (8212)25-95-17
Тамбов (4752)50-40-97
Тверь (4822)63-31-35

Тольятти (8482)63-91-07
Томск (3822)98-41-53
Тула (4872)33-79-87
Тюмень (3452)66-21-18
Улан-Удэ (3012)59-97-51
Ульяновск (8422)24-23-59
Уфа (347)229-48-12
Хабаровск (4212)92-98-04
Чебоксары (8352)28-53-07
Челябинск (351)202-03-61
Череповец (8202)49-02-64
Чита (3022)38-34-83
Якутск (4112)23-90-97
Ярославль (4852)69-52-93

Россия +7(495)268-04-70

Казахстан +7(7172)727-132

Киргизия +996(312)96-26-47

yne@nt-rt.ru || <https://yuken.nt-rt.ru>

Model Number Designation

PMR2	-6	—	-70	—	-A	-01	-A200	—	—	-40
PPF2	-6	-3	-70	-R	—	-01	-A200	-V1	-F	-35
Series Number	Geometric Displacement of Pump cm ³ /rev	Adj. Flow L/min	Relief Valve Setting Pressure	Direction of Pump Rotation	Electric Motor Code	Circuit Symbol ^{★2}	Directional Valve Type ^{★3}	Pulley Type	Mounting Type	Design Number
PMR2 : Motor Drive Type		—	Please specify at the range of 3.5 - 14 MPa. ^{★1}	(Clockwise Viewed from the Motor Fan)	A : 1.5 kW×6 P B : 2.2 kW×4 P 200/220V AC N : Without Motor	00 01 02	M : Manually Operated Directional Valve Solenoid Operated Directional Valve :	—	—	40
PPF2 : Pulley Drive Type with Flow Adjustment	^{★4} 6 : 5.8 8 : 8.0 10 : 9.4 12 : 12.2 14 : 13.7 17 : 16.6	^{★4} 2, 3, 4 7, 8, 9 10, 12 15, 20 25	Please specify at the range of 3.5 - 10.5 MPa. ^{★1}	(Viewed from the Shaft End) R : Clockwise L : Anti-Clockwise	—	03 04 05 06 07 08	D12, D24 (AC) A100, A200 Circuit Symbol "00" or "08" : None	N : Without Pulley V1S : JIS 5 V Type 158.4 Dia. Single Pulley V1 : JIS 5 V Type 208.4 Dia. Single Pulley	F : Flange Mtg. Type L : Foot Mtg. Type	35

★ 1. Please specify the controlled pressure as of MPa×10.

(Ex.) ● In Case of 3.5 MPa..... Please specify as of 35.

★ 2. For details of circuit symbol, please refer to the standard circuit on pages K-54 and K-55. In case of "00", no control valves embedded.

★ 3. As for solenoid operated directional valves, we use the DSG-01 series solenoid operated directional valves. For details of coil type, please refer to page K-76. As for manually operated directional valves, we use the DMG-01 models.

★ 4. For the combination possibility between the geometric displacement of pump and the adjustment flow, see the table below.

Geometric Displacement of Pump	Adj. Flow L/min										
	2	3	4	7	8	9	10	12	15	20	25
6	○	○	○	○	○	○					
8	○	○	○	○	○	○	○	○			
10	○	○	○	○	○	○	○	○	○		
12			○	○	○	○	○	○	○	○	
14				○	○	○	○	○	○	○	○
17						○	○	○	○	○	○

Instructions

● Exchange Period of Hydraulic Fluid

Please exchange after having operated 100 hours at the first time. After then, please exchange every 500 hours or one year of operation.

● Fluid Supply and Oil Level Change

Please supply oil after the air breather removed. Confirm the amount of supplied oil by the oil gauge attached on the air breather. Please keep oil level between low limit and high limit mark at the range of 3.2 - 3.4 L. (Avoid over fluid supply that will cause the external oil leakage from the air breather with the oil level change.) The low limit fluid level is on the center axial line (2.1 L), so use within approx. 1.3 L of the oil level change by the actuator operation. If use as like as inclined oil level condition, please consult us separately because of the restriction of oil level change amount.

● Mounting Position

As for mounting, please mount horizontally with the air breather upward. (Avoid vertical mounting with the tank upward or downward.)

● Axial Load (Pulley Drive Type with Flow Adjustment)

As for the axial load, please keep less than 1000 N for radial load and less than 100 N for thrust load.

● Notice on Starting

On starting, please perform intermittent operation under unloaded condition.

● Please avoid long time operation under whole amount relieving condition that will waste energy and cause oil temperature rise.

● Relief Valve Setting Pressure

The discharge pressure on shipping is set by the "Relief Valve Setting Pressure" in the above table "Model Number Designation". Regardless of the designation, the relief valve setting pressure is able to adjust at the range of 3.5 - 14 MPa (3.5 - 10.5 MPa only for PPF2 type).

When pressure increasing, please pay enough attention to the motor/engine overload by power requirement increase.

Standard Circuit

The hydraulic circuit configuration is easy only by stacking DSG-01 series solenoid operated directional valve or manually operated directional valve and modular valves on this power package.

There are 15 types of standard circuits for power package as the chart below. If need non-standard circuits, please specify the power package with no control valves (circuit symbol “00”) and order DSG-01 series solenoid operated directional valve or manually operated directional valve and modular valves separately.

For details of DSG-01 series solenoid operated directional valve, manually operated directional valve and modular valves, please refer to the applicable pages on catalog of “E: DIRECTIONAL CONTROLS” and “F: MODULAR VALVES”.

With Solenoid Operated Directional Valve

Circuit Symbols	01	02	03	04
Graphic Symbols				
Dimensions				
Additional Mass	1.9 kg	3.3 kg	3.3 kg	3.5 kg
Circuit Symbols	05	06	07	08
Graphic Symbols				
Dimensions				
Additional Mass	3.2 kg	4.5 kg	4.7 kg	0.6 kg

● With Manually Operated Directional Valve

Circuit Symbols	01	02	03	04
Graphic Symbols				
Dimensions				
Additional Mass	1.8 kg		3.2 kg	3.4 kg
Circuit Symbols	05	06	07	08
Graphic Symbols				
Dimensions				
Additional Mass	3.1 kg	4.4 kg	4.6 kg	0.6 kg

Note) The lever position of manually operated directional valve can be changed. (See the drawing below)

● Change The Lever Position of Manually Operated Directional Valve

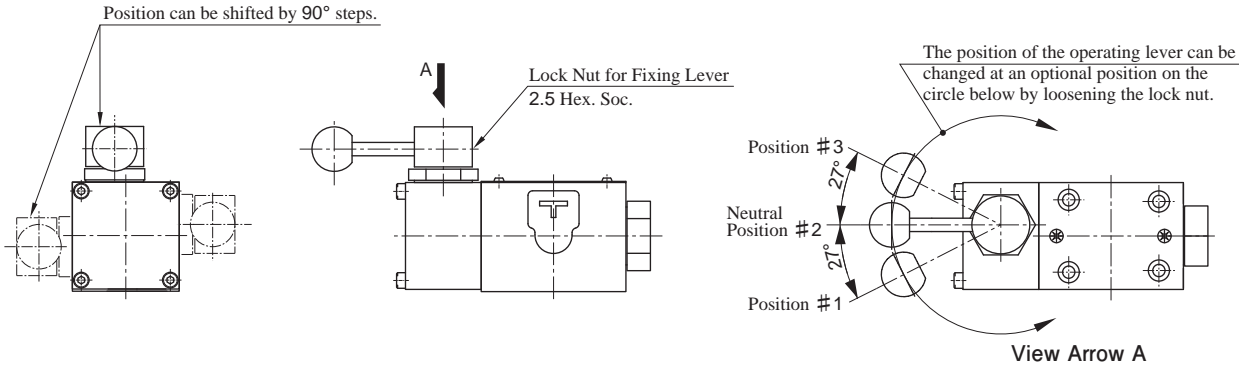

Characteristics of PMR2 Type The below charts show the representative characteristics of viscosity 20 mm²/s.

Pressure vs. Output Flow

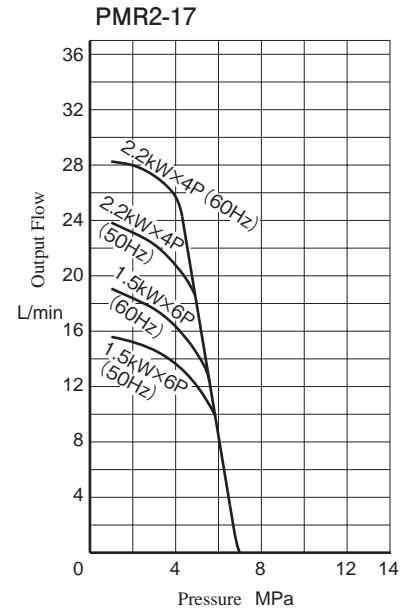
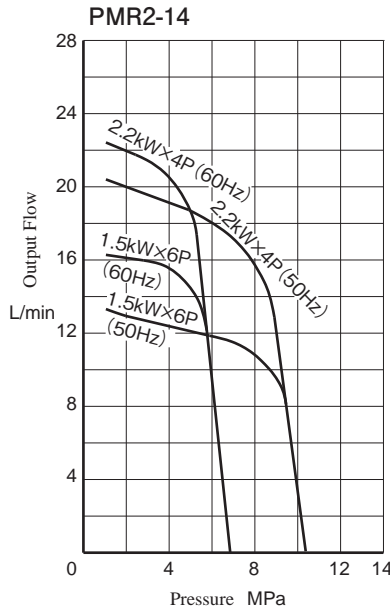
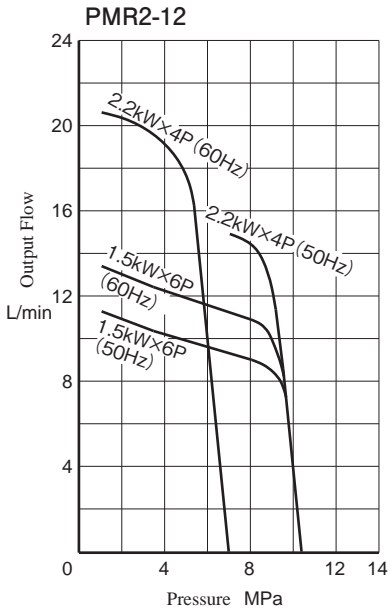
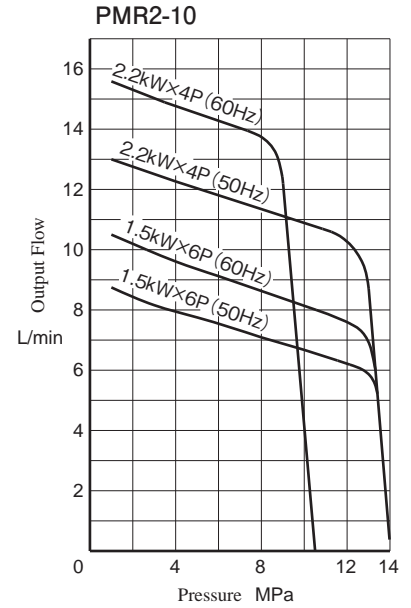
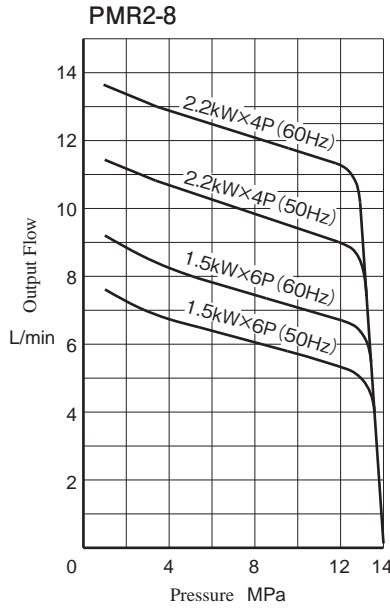
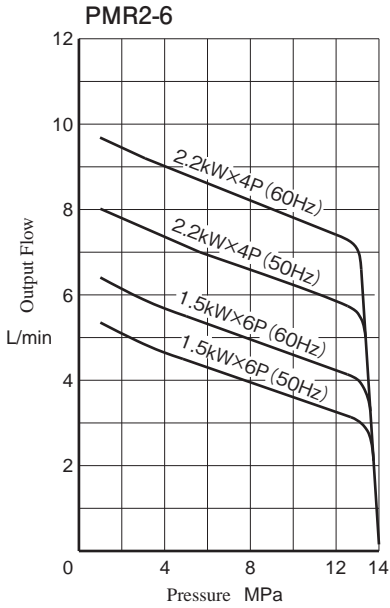

Max. Operating Pressure at Rated Motor Power

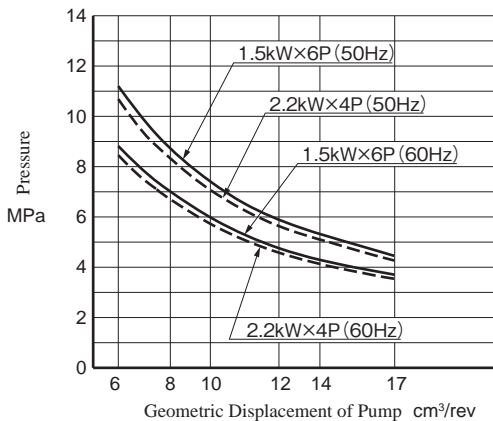

Note) The characteristics of pressure vs. output flow above indicate at the range of rated motor power 200% or less. For the max. operating pressure at rated motor power, see the left chart.

Characteristics of PPF2 Type

The below charts show the representative characteristics of viscosity 20 mm²/s.

Rotational Speed vs. Output Flow (Pressure 6 MPa)

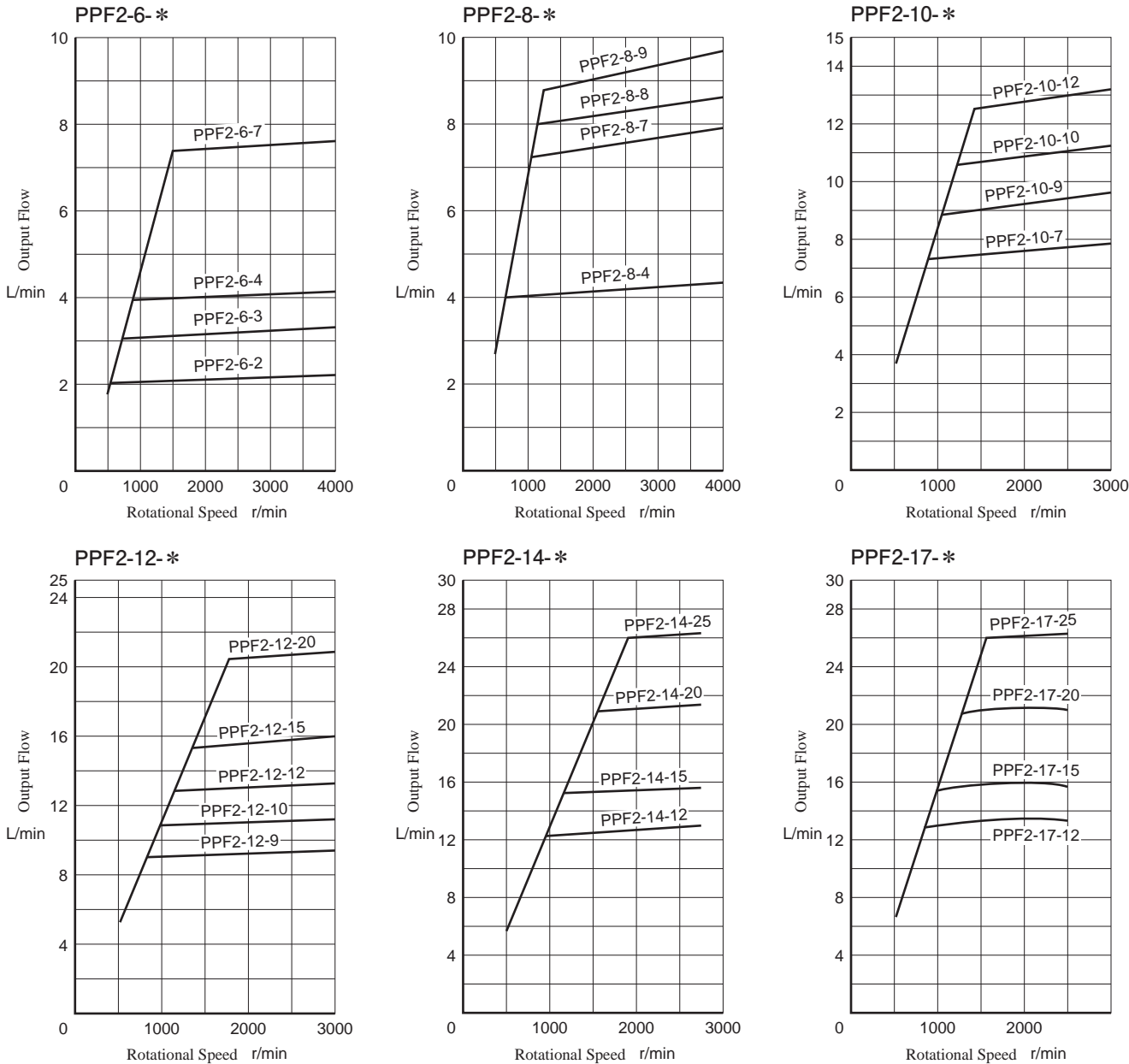

Pressure vs. Torque

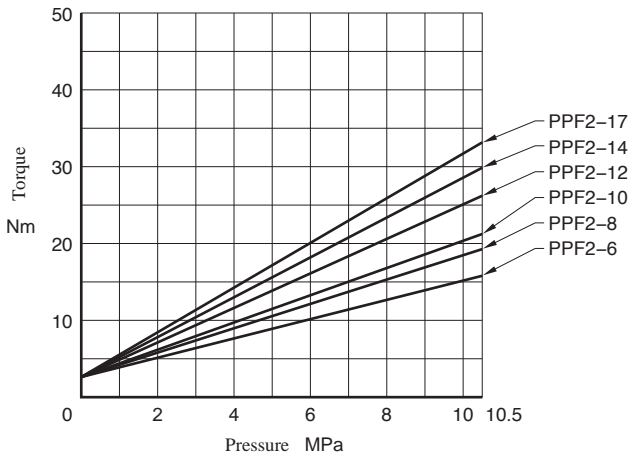

Axial Input

The requirement torque is determined by geometric displacement of pump and pressure regardless of the rotational speed. The axial input is calculated from the formula below.

$$L_i = \frac{2\pi TN}{60000}$$

- L_i : Axial Input kW
- T : Requirement Torque Nm
- N : Rotational Speed r/min

PMR2-*-A-B-00**

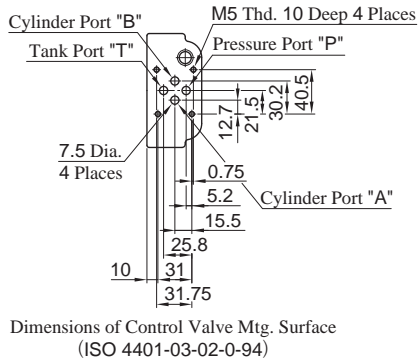
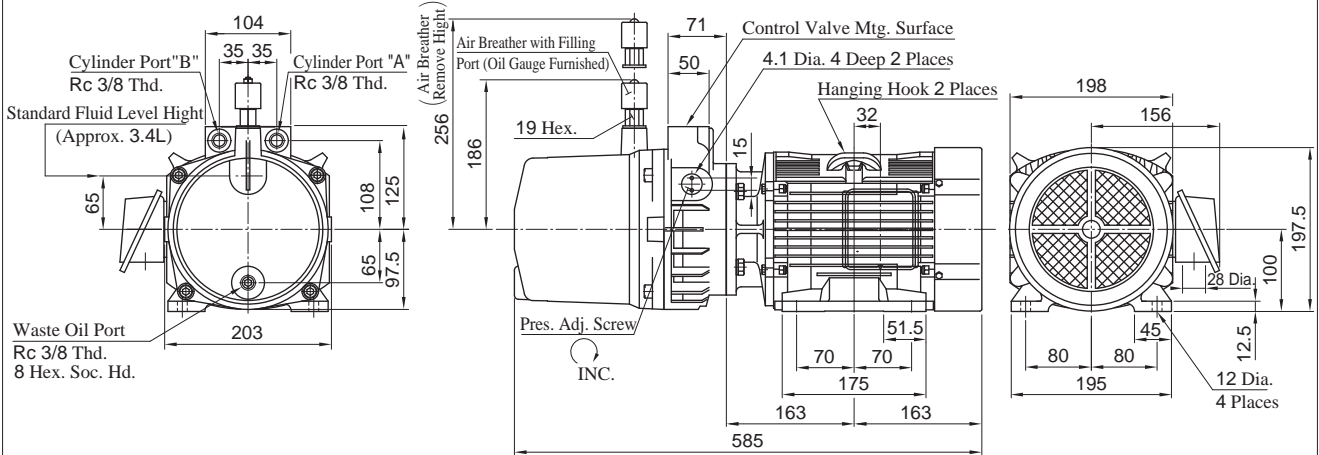

PMR2-*-N-00**

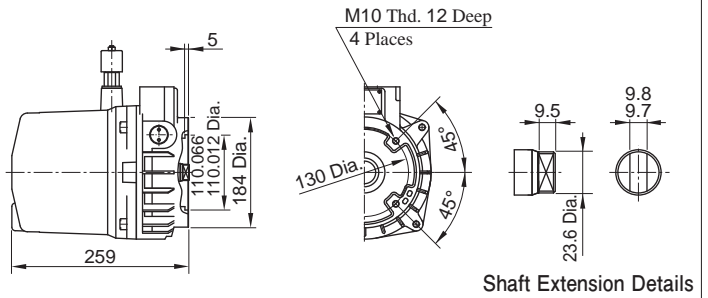

For other dimensions, refer to the drawing above.

PPF2-*-***-00**

Flange Mtg. Type

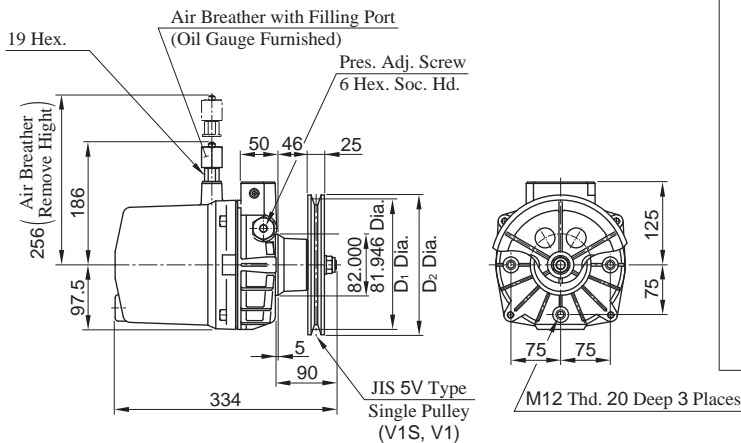

Foot Mtg. Type

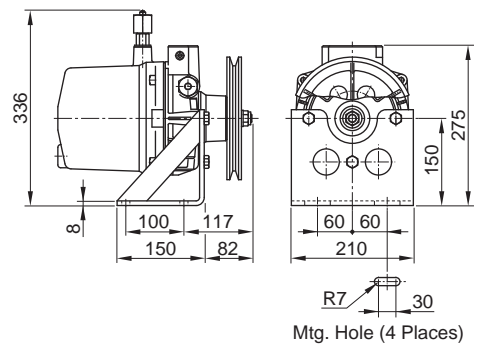

For other dimensions, refer to the flange mtg. type.

Pulley Type	D ₁	D ₂
V1S	158.4	161
V1	208.4	211

● For other dimensions, refer to the PMR2 type above.

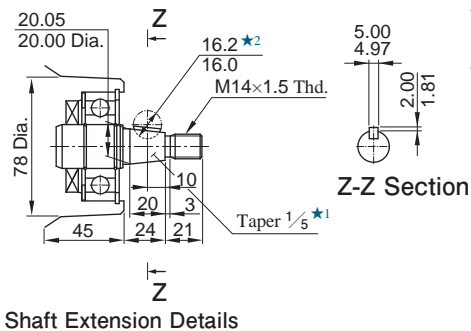

- ★1. Taper Angle Tolerance: : JIS B 0614 AT6
- ★2. Semilunar Key: : JIS B 1301 WA 5×16

Interchangeability between Current and New Models

■ PMR2,35 Design → 40 Design

● Major Changes

To conform to The Motor Top Runner Criteria, we changed the motor drive type power package PMR2 model.

- Motor efficiency class is changed to IE3, so the motor specifications improved generally.
- The sizes of the current and new motor are almost same, the mass increased (mass ratio 139,145%).

● Comparison of Motor Specifications

Output×Number of Poles	Voltage—Frequency V Hz	Rated Current A	Inrush Current A	Rotational Speed r/min	Insulation Class
1.5 kW×6P	200—50	8.0 (7.5)	63.9 (35.5)	965 (948)	F (E)
	200—60	7.0 (6.8)	53.3 (32.5)	1160 (1134)	
	220—60	7.0 (6.6)	58.6 (35.8)	1170 (1147)	
2.2 kW×4P	200—50	9.8 (9.9)	93.2 (58.0)	1460 (1448)	F (E)
	200—60	8.8 (8.9)	79.1 (53.0)	1755 (1730)	
	220—60	8.6 (8.6)	87.0 (58.5)	1765 (1744)	

Note 1) The difference between current and new design indicates in the parenthesis.

Without Parenthesis: New 40 Design, Within Parenthesis: Current 35 Design

2) The starting current of new 40 design is larger in comparison with current 35 design. Please pay attention to the power distribution design.

3) The rotational speed of new 40 design is faster in comparison with current 35 design by the improvement of slip down.

By the operating conditions, “Output Increase” or “Over Flow” is possible, so please pay attention.

* Because of the improvement in the flow rate characteristics of power package, actually the output increase.

● Interchangeability in Installation

There is interchangeability in installation, but the dimension from the center of motor to the end of terminal box (KL) is slightly longer.

● Comparison of Dimensions

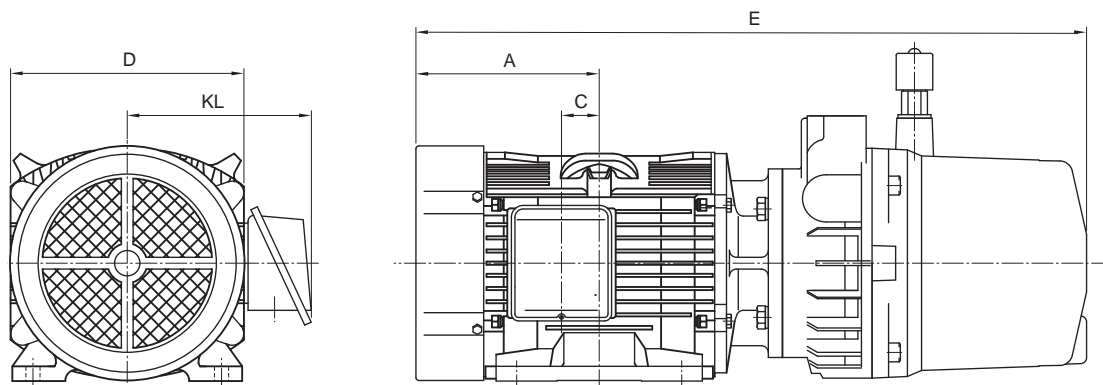

Model Numbers	Dimensions mm					Mass kg
	A	C	D	E	KL	
Current PMR2- * - * -A- * - * -35	163.5	46	199	585.5	153	36
New PMR2- * - * -A- * - * -40	163	32	198	585	156	50
Current PMR2- * - * -B- * - * -35	163.5	46	199	585.5	153	35.5
New PMR2- * - * -B- * - * -40	163	32	198	585	156	51.5

Note) The other dimensions are same, please refer to the drawing of dimensions.

List of Cartridge Kits, Seals and Bearings

PMR2

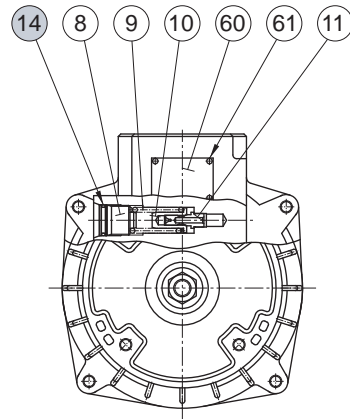
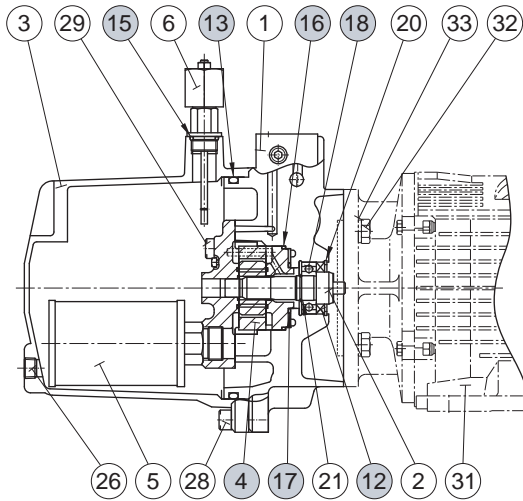

PPF2

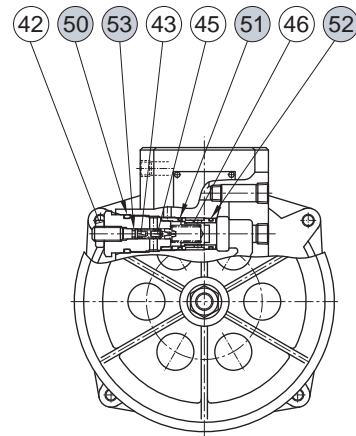
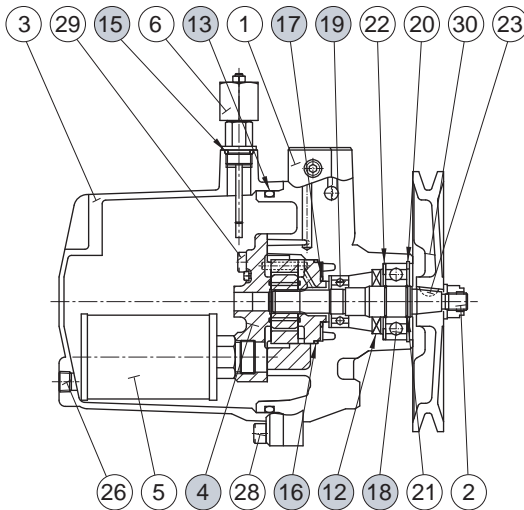

● List of Seals and Bearings

Item	Name of Parts	Part Numbers		Qty.
		PMR2	PPF2	
12	Oil Seal	ISD 26428	SC 25528	1
13	O-Ring	OR NBR-70-1 G170-N	OR NBR-70-1 G170-N	1
14	O-Ring	OR NBR-90 P21-N	—	1
15	O-Ring	OR NBR-90 P18-N	OR NBR-90 P18-N	1
16	O-Ring	AS568-144 (FKM-90)		(1)
17	O-Ring	AS568-125 (FKM-90)		(1)
50	O-Ring	—	OR NBR-90 P25-N	1
51	O-Ring	—	OR NBR-90 P22-N	1
52	O-Ring	—	OR NBR-90 P21-N	1
53	O-Ring	—	OR NBR-70-1 P5-N	1
18	Bearing	6004	6305DDU-D4M-K	1
19	Bearing	—	6004	1

● List of Cartridge Kits

Model Numbers	④ Cartridge Kit Numbers
PMR2-★	CP2-★-R-40
PPF2-★-*-*-R	CP2-★-R-40
PPF2-★-*-*-L	CP2-★-L-40

Note) ★ parts in the chart above are filled by the geometric displacement of pump.
(Refer to the model number designation on page K-53)

Note) O-Rings of item ⑬ and ⑭ are included in the cartridge kit ④.

По вопросам продаж и поддержки обращайтесь:

Алматы (7273)495-231	Калининград (4012)72-03-81	Омск (3812)21-46-40	Сыктывкар (8212)25-95-17
Ангарск (3955)60-70-56	Калуга (4842)92-23-67	Орел (4862)44-53-42	Тамбов (4752)50-40-97
Архангельск (8182)63-90-72	Кемерово (3842)65-04-62	Оренбург (3532)37-68-04	Тверь (4822)63-31-35
Астрахань (8512)99-46-04	Киров (8332)68-02-04	Пенза (8412)22-31-16	Тольятти (8482)63-91-07
Барнаул (3852)73-04-60	Коломна (4966)23-41-49	Пермь (342)205-81-47	Томск (3822)98-41-53
Белгород (4722)40-23-64	Кострома (4942)77-07-48	Петрозаводск (8142)55-98-37	Тула (4872)33-79-87
Благовещенск (4162)22-76-07	Краснодар (861)203-40-90	Псков (8112)59-10-37	Тюмень (3452)66-21-18
Брянск (4832)59-03-52	Красноярск (391)204-63-61	Ростов-на-Дону (863)308-18-15	Улан-Удэ (3012)59-97-51
Владивосток (423)249-28-31	Курган (3522)50-90-47	Рязань (4912)46-61-64	Ульяновск (8422)24-23-59
Владикавказ (8672)28-90-48	Курск (4712)77-13-04	Самара (846)206-03-16	Уфа (347)229-48-12
Владимир (4922)49-43-18	Липецк (4742)52-20-81	Санкт-Петербург (812)309-46-40	Хабаровск (4212)92-98-04
Волгоград (844)278-03-48	Магнитогорск (3519)55-03-13	Саранск (8342)22-96-24	Чебоксары (8352)28-53-07
Вологда (8172)26-41-59	Москва (495)268-04-70	Саратов (845)249-38-78	Челябинск (351)202-03-61
Воронеж (473)204-51-73	Мурманск (8152)59-64-93	Севастополь (8692)22-31-93	Череповец (8202)49-02-64
Екатеринбург (343)384-55-89	Набережные Челны (8552)20-53-41	Симферополь (3652)67-13-56	Чита (3022)38-34-83
Иваново (4932)77-34-06	Нижний Новгород (831)429-08-12	Смоленск (4812)29-41-54	Якутск (4112)23-90-97
Ижевск (3412)26-03-58	Новокузнецк (3843)20-46-81	Сочи (862)225-72-31	Ярославль (4852)69-52-93
Иркутск (395)279-98-46	Новосибирск (383)227-86-73	Ставрополь (8652)20-65-13	
Казань (843)206-01-48	Ноябрьск (3496)41-32-12	Сургут (3462)77-98-35	

Россия +7(495)268-04-70

Казахстан +7(7172)727-132

Киргизия +996(312)96-26-47

yne@nt-rt.ru || <https://yuken.nt-rt.ru>