

Instructions

- When using the rod push side output, make sure that the screw is tightened to the rod end face so that no force is applied to the threaded part of the piston rod.
- Since a lateral load (eccentric load) cannot be applied to the piston rod, be careful when adjusting it at the time of mounting.
- When operating the cylinder for the first time, be sure to bleed air from the piping section. After venting, operate the cylinder with the pressure lowered and gradually increase the pressure up to the working pressure.
Note: The CBY14 series does not have an air vent, so be sure to vent the air from the piping section.
- Use four socket head cap screws (JIS B1176, strength class 10.9 or higher) for mounting the cylinder.
- When mounting bolts are used, screw the bolts into the mounting member at least 80% of their thread diameter. Use a mounting material with a strength equivalent to SS400.
- When tightening mounting bolts with nuts, use steel nuts with a strength class of 6 or higher. (However, do not use a type 3 nut.)
- When fastening the cylinder body with mounting bolts, be sure to tighten them to the tightening torques shown in the table below.

Tightening Torque of Mounting Bolts

Cylinder Bore	Mounting Bolt Size	Tightening Torque Nm
32	M6×1	5.9
40	M8×1.25	14.0
50	M10×1.5	28.0
63	M12×1.75	49.0
80	M14×2	77.0
100	M16×2	120.0

- When tightening the piston rod end screws of double-acting double-rod type, be sure to use the hex. of the rod on the side to be tightened. Since the double-rod type piston rod is fastened with a screw, be careful not to apply a rotating force to the rod at both ends of the piston rod.

Disassembly and Assembly

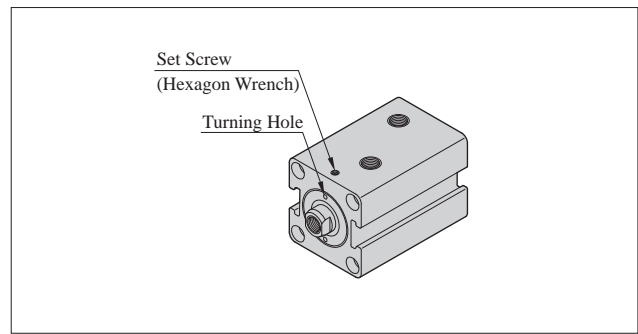

- After removing the set screw, remove the bush from the cylinder body using the turning hole in the bush. When removing the jig etc. of the rod end screw, remove any burrs on the rod hex. with a file, etc., and remove the bush afterward.
- The piston rod and piston cannot be disassembled.
- When disassembling the cylinder, replace all seals (packings and gaskets).
- When assembling the cylinder, be careful not to allow dust, iron powder, or other foreign matter to enter the cylinder.
- There is a copper rod under the set screw to protect the bush threads. Remove it before tightening the bush.
- After tightening the bush, insert the copper rod included in the packing set and tighten the set screw.
- When using a cylinder with a switch (CBY14L or CBY14LN), refer to instructions on page J-85.

Replacement of Packing

- Piston packings, rod packings, dust seals, and O-rings for bush can be replaced.
- O-rings for piston rods are not replaceable because they have been designed to prevent loosening of the piston and rod.
- Bush turning hole dimensions

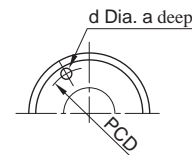

Cylinder Bore	a	d	PCD
32	5	4	32
40	7	4	38
50	8	5	46
63	9	5	58
80	10	8	70
100	12	10	85

Алматы (7273)495-231
Ангарск (3955)60-70-56
Архангельск (8182)63-90-72
Астрахань (8512)99-46-04
Барнаул (3852)73-04-60
Белгород (4722)40-23-64
Благовещенск (4162)22-76-07
Брянск (4832)59-03-52
Владивосток (423)249-28-31
Владикавказ (8672)28-90-48
Владимир (4922)49-43-18
Волгоград (844)278-03-48
Вологда (8172)26-41-59
Воронеж (473)204-51-73
Екатеринбург (343)384-55-89

Иваново (4932)77-34-06
Ижевск (3412)26-03-58
Иркутск (395)279-98-46
Казань (843)206-01-48
Калининград (4012)72-03-81
Калуга (4842)92-23-67
Кемерово (3842)65-04-62
Киров (8332)68-02-04
Коломна (4966)23-41-49
Кострома (4942)77-07-48
Краснодар (861)203-40-90
Красноярск (391)204-63-61
Курган (3522)50-90-47
Курск (4712)77-13-04
Липецк (4742)52-20-81

Магнитогорск (3519)55-03-13
Москва (495)268-04-70
Мурманск (8152)59-64-93
Набережные Челны (8552)20-53-41
Нижегород (831)429-08-12
Новокузнецк (3843)20-46-81
Новосибирск (383)227-86-73
Ноябрьск (3496)41-32-12
Омск (3812)21-46-40
Орел (4862)44-53-42
Оренбург (3532)37-68-04
Пенза (8412)22-31-16
Пермь (342)205-81-47
Петрозаводск (8142)55-98-37
Псков (8112)59-10-37

Ростов-на-Дону (863)308-18-15
Рязань (4912)46-61-64
Самара (846)206-03-16
Санкт-Петербург (812)309-46-40
Саранск (8342)22-96-24
Саратов (845)249-38-78
Севастополь (8692)22-31-93
Симферополь (3652)67-13-56
Смоленск (4812)29-41-54
Сочи (862)225-72-31
Ставрополь (8652)20-65-13
Сургут (3462)77-98-35
Сыктывкар (8212)25-95-17
Тамбов (4752)50-40-97
Тверь (4822)63-31-35

Тольятти (8482)63-91-07
Томск (3822)98-41-53
Тула (4872)33-79-87
Тюмень (3452)66-21-18
Улан-Удэ (3012)59-97-51
Ульяновск (8422)24-23-59
Уфа (347)229-48-12
Хабаровск (4212)92-98-04
Чебоксары (8352)28-53-07
Челябинск (351)202-03-61
Череповец (8202)49-02-64
Чита (3022)38-34-83
Якутск (4112)23-90-97
Ярославль (4852)69-52-93

"CBY14" Series Compact Type Hydraulic Cylinders

Compared to conventional cylinders, YUKEN's thin cylinder "CBY14 Series" is 1/3 the overall length, making it possible to mounting in places where conventional cylinders cannot be mounted due to lack of space.

- **Economical selection is possible**
Up to 16 MPa can be used by selecting the operating pressure and the number of times.
- **Lightweight and compact design**
The cylinder tube and cover are integrated into a single unit, allowing mounting in a small space, thus saving space. Also, it is a lightweight type using a special aluminum alloy for the main body.
- **Wide Variety**
A wide variety of models are available, including cylinder bore 32 to 100, mounting type, rod shape, and with switches. Select the one that best suits your application.
- **Highly durable rod bush and piston**
Rod bush and piston are made of a special copper alloy to anti-wear resistance.
- **Easy Maintenance**
Maintenance is extremely easy, as the packing can be replaced simply by loosening the rod bush without removing the main unit or piping.

Specifications

Model Numbers	Single Rod Type	Double Rod Type
Descriptions	CBY14*-***N***	CBY14*N-***N***
Cylinder Bore mm	32, 40, 50, 63, 80, 100	
Mounting Type	SD, LD, FA, FB	SD, LD, FA
Rated Pressure ^{★1}	Cylinder Bore 32, 40, 50 14MPa (fatigue endurance times 2.5×10^6) ^{★2} 12MPa (fatigue endurance times 1.0×10^7) Cylinder Bore 63, 80, 100 14MPa (fatigue endurance times 9.0×10^5) ^{★2} 10MPa (fatigue endurance times 1.0×10^7)	
Pressure Proof	20 MPa	
Minimum Working Pressure	0.3 MPa	
Operating Speed	8 - 100 mm/s	
Standard Stroke mm	Refer to next page "Model Number Designation"	
Tolerance of Stroke mm	0 - 0.8	
Tolerance of Thread	JIS B 0211-6H / 6 g	
Ambient Temperature Range (Ambient and Oil Temperature)	-10 - +70°C (No Freezing)	

- Approx. Mass may be obtained from the formula below.
 $[Mass] = [Basic Mass] + [Additional Mass by a unit stroke \text{ Imm} \times \text{Stroke (mm)}]$
 The basic mass and the additional mass per 1 mm stroke are shown in the external dimensional drawings, so please obtain them from the external dimensional drawing of the corresponding model numbers.
- ★1. For the relationship between rated pressure and fatigue endurance times, refer to the "Rated Pressure Diagram".
- ★2. Please consult us if you require a fatigue endurance times of 1.0×10^7 or higher at 14 MPa.

Double Acting Single Rod Cylinder

Graphic Symbols

Basic Type CBY14 With Switch CBY14L

Basic Type With Switch

Double Acting Double Rod Cylinder

Graphic Symbols

Basic Type CBY14N With Switch CBY14LN

Basic Type With Switch

Rated Pressure Diagram

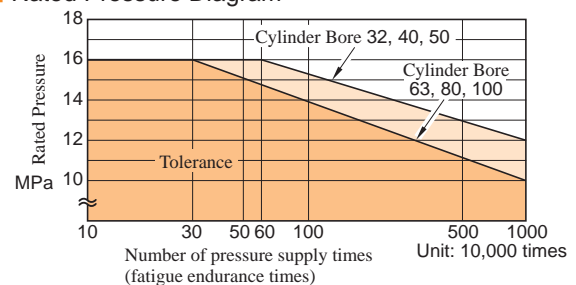

How to read a diagram

- The horizontal axis is the number of times the pressure is supplied to the cylinder.
- The pressure that rises vertically and intersects the limit line of each bore is the pressure (rated pressure) that can be used up to that number of supply times. (Probability of breakdown: 1%)

Examination Methods

To calculate the rated pressure, a fatigue test is conducted with reference to JFPS 1014: 2002 (Japan Fluid Power Industry Association Standard) "Guidelines for Selection and Use of Hydraulic Cylinders Appendix 2 Strength Test Methods for Hydraulic Cylinders".

Specifically, pressure is repeatedly applied to dozens of supply cylinders, the number of times they break is measured, and statistically processed to obtain the rated pressure.

Determining Rated Pressure Methods

- Fatigue life is determined by substantive fatigue testing as described in the test methods and by statistically processing the data.
 - The life distribution is obtained from actual fatigue test data, and the rating diagram is based on the value of 1% probability of fracture in the distribution.
- Note: There is no point of 0% in the statistical method.

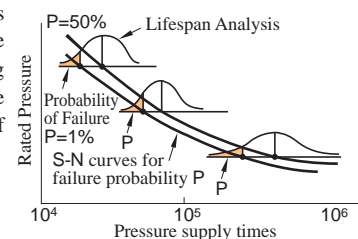

Model Number Designation

CBY14L	-6	SD	40	N	50	T	G	X1	2	-L
Series Number	Packing Material	Mounting Type	Cylinder Bore (mm)	Cushion Type	Stroke ^{★8} (mm)	Thread ^{★6}	Port	Switch Code	Switch Quantity	Lock Nut
CBY14 : 14 MPa Double Acting Single Rod Type		SD : Basic Type			Cylinder Bore 32 - 80 : 5,10,15,20,25,30, 35,40,45,50,60, 70,80,90,100			-	-	
CBY14L : 14 MPa Double Acting Single Rod Type (with switch) ^{★5}	3 : Fluoro Rubber	LD : Foot Mounting	32, 40, 50, 63, 80, 100	N : Without Cushion	Cylinder Bore 100 : 5,10,15,20,25, 30,35,40,45,50	None : Internal Thread	None : Rc Thread	10 ^{★3} codes	1, 2	None : None
CBY14N : 14 MPa Double Acting Double Rod Type	6 : Hydrogenated Nitrile Rubber (Standard)	FA : Rod Flange			5,10,15,20,25, 30,35,40,45,50	T : External Thread	G : ^{★2} G Thread	-	-	L : 1 Lock Nut ^{★4}
CBY14LN : 14 MPa Double Acting Double Rod Type (with switch) ^{★5}		FB ^{★1} : Cap Flange						10 ^{★3} codes	1, 2	

- ★1. Mounting type FB : Cap flange type is not available for double acting double rod cylinder (CBY 14N/CBY14LN).
- ★2. Port G : G thread is available only for mounting type SD : basic type.
- ★3. For the switch code, select one of the 10 codes shown in the table below. All switches are CE compliant.
- ★4. When lock nuts are required on both sides of a double rod cylinder, please arrange one lock nut separately by referring to page J-86.
- ★5. Switches are not mounted on the cylinder body, but are shipped in the same package as the cylinder body.
- ★6. Lock nut "-L" is not available for internal thread. If you need a lock nut, please arrange it separately.
In the case of double acting double rod cylinder, both sides are of internal thread or external thread.
- ★7. Refer to "Specifications of Switch" on the next page to determine the switch type. For switch types other than those shown on the next page, please consult us separately.
- ★8. For arbitrary stroke, please consult us separately.

Switch Code	Switch Type	Details		Indicator Light
N1	AX101CE	Contact Type	Lead Wire 1.5m	Light Emitting Diode (Red color lighting when switch is "ON".)
N5	AX105CE		Lead Wire 5m	
X1	AX111CE		Lead Wire 1.5m	
X5	AX115CE		Lead Wire 5m	
XA	AX11ACE		Plug-in Connector(AC)	
XB	AX11BCE		Plug-in Connector(DC)	
Y1	AX201CE-1	Contactless Type	Lead Wire 1.5m	Light Emitting Diode (2-lighting type Red/Green)
Y5	AX205CE-1		Lead Wire 5m	
M1	AX211CE-1		Lead Wire 1.5m	
M5	AX215CE-1		Lead Wire 5m	

Specification of Switch(All switches are CE-compliant)

		Contact Switch						Contactless Switch			
Type	Lead Wire 1.5m	AX101CE	—	AX111CE	—	—	—	AX201CE	—	AX211CE	—
	Lead Wire 5m	—	AX105CE	—	AX115CE	—	—	—	AX205CE	—	AX215CE
	Plug-in Connector (AC) ^{★3}	—	—	—	—	AX11ACE	—	—	—	—	—
	Plug-in Connector (DC) ^{★3}	—	—	—	—	—	AX11BCE	—	—	—	—
Load Voltage Range	5 to 120 V AC 5 to 30 V DC			5 to 120 V AC 5 to 30 V DC			5 to 30 V DC				
Load Current Range	5 to 20 mA AC 5 to 40 mA DC			5 to 20 mA AC 5 to 40 mA DC			5 to 40 mA DC				
Maximum Switching Capacity	2 VA : AC 1.5W : DC			2 VA			1.5 W				
Voltage Drop	TYP ; 2 V (at 10 mA) 3 V or less						4 V or less				
Current Leakage	10μA or less						0.1 A or less				
Operating Time	1 ms or less						10 ms or less				
Repeatability	1 ms or less						10 ms or less				
Insulation Resistance	100 MΩ or more (between case and cord) at 500 V DC mega										
Voltage Proof	1500 V AC for 1 minute (between case and cord)										
Shock Proof	294 m/s ² (Non-Repetitive)						490 m/s ² (Non-Repetitive)				
Vibration Proof	±0.75mm amplitude, 10 to 55 Hz (1 sweep, 1 minute) 2 hours in each direction X, Y, Z						±0.3mm amplitude, 10 to 200 Hz (Log sweep, 1 hour) X, Y, Z directions				
Ambient Temperature	-10 - +70°C (No Freezing)										
Wiring Method	0.3 mm ² 2-Core, outer diameter 4 mm oil-resistant cabtyre cord										
Protective Structure	IP67 (IEC standard), JIS C 0920 (dust and immersion proof)										
Contact Protection Circuit	Not available ^{★4}			Available							
Indicator Light	Light Emitting Diode (Red color lighting when switch is "ON".)									Light Emitting Diode (2-lighting type Red/Green)	
Allowable Length of Wire ^{★2}	10 m : AC 100 m : DC						10 m				
Compatible Load	Compact Relay Programmable Controller										

★1. In the case of DC power supply, pay attention to the polarity (color of the lead wires or position of the plus/minus terminals of the connector) and make sure that the wiring is correct.

★2. If the wiring length exceeds the allowable wiring length, please consult us.

★3. The connector used for the type with connector is NECA (Nippon Electric Control Equipment Industries Association standard) 4202 connector for FA sensors (M12 x 1).

★4. When using an inductive load (relay, etc.) without a contact protection circuit, be sure to attach a protection circuit to the load.

Minimum Stroke for Switch Mounting

Unit : mm

1 switch mounted	2 switch mounted
5	10 ^{★1,2}

Note: When using two contact switches on one side with 10 strokes, the switches may interfere with each other, so please adjust the switches.

★1. When using a contactless switch with 10 strokes, use two switch mounting slots.

★2. For two or more switches, please consult us separately.

Switch Additional Mass

Unit : kg

Lead Wire 1.5m	Lead Wire 5m	Plug-in Connector
0.05	0.13	0.04

Compatibility of Hydraulic Fluid and Packing Material

Packing Material	Hydraulic Fluid				
	Petroleum Base Oil	Water-Glycols	Phosphate Esters	Water in Oil Emulsion	Oil in Water Emulsion
"3" Fluoro Rubber	○	×	○	○	○
"6" Hydrogenated Nitrile Rubber	○	◎	×	◎	◎

Note 1. The mark ◎ and ○ are allowed, × is not allowed.

2. The mark ◎ is the recommended packing for anti-wear.

**Single Rod, Mounting SD :
Basic Type**

Standard CBY14- *SD
With Switch CBY14L- *SD

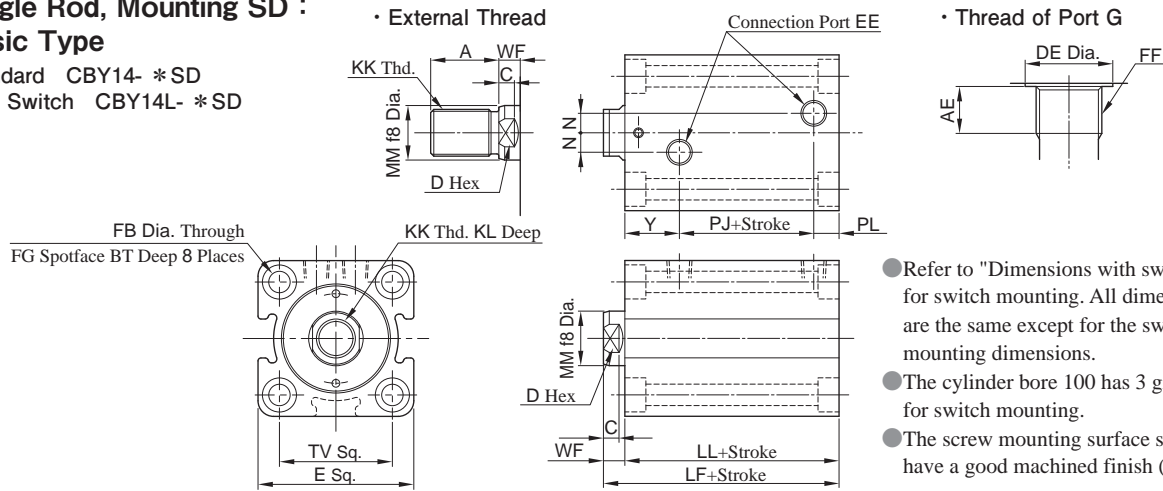

- Refer to "Dimensions with switch" for switch mounting. All dimensions are the same except for the switch mounting dimensions.
- The cylinder bore 100 has 3 grooves for switch mounting.
- The screw mounting surface should have a good machined finish (▽).

Bore	A	AE	BT	C	D	DE	E	EE	FB	FF	FG	KK		KL	LF	LL	MM	N		PJ		PL		TV	WF	Y		Mass kg		
												Internal Thread	External Thread					Rc Thd.	G Thd.	Rc Thd.	G Thd.	Rc Thd.	G Thd.			Rc Thd.	G Thd.	Rc Thd.	G Thd.	Basic Int. Thd.
32	25 (40)	8	6.5	7	14	17.2	62	Rc1/4	6.6	G1/8	11	M12×1.75	M16×1.5	15	64	54	18	10	10	14	14	12	12	47	10	28	28	0.64	0.009	0.05
40	30 (45)	8	8.6	7	19	17.2	70	Rc1/4	9	G1/8	14	M16×2	M20×1.5	20	65	55	22	10	10	16	16	12	12	52	10	27	27	0.85	0.011	0.10
50	35 (50)	12	10.8	8	24	21.5	80	Rc1/4	11	G1/4	17.5	M20×2.5	M24×1.5	24	71	60	28	10	14	19	13.5	13	18.5	58	11	28	28	1.28	0.015	0.18
63	45 (60)	12	13	9	30	21.5	94	Rc1/4	14	G1/4	20	M27×3	M30×1.5	33	80	67	36	10	16	24	20	13	17	69	13	30	30	2.00	0.021	0.40
80	60 (80)	12	15.2	14	41	21.5	114	Rc3/8	16	G1/4	23	M30×3.5	M39×1.5	36	95	78	45	15	19	25	24	18	18	86	17	35	36	3.72	0.031	0.76
100	75 (95)	12	17.5	22	50	25.5	138	Rc3/8	18	G3/8	26	M39×4	M48×1.5	45	122	96	56	15	18	26	26	28	28	106	26	42	42	7.03	0.046	1.50

Note: When using a lock nut, dimension A in parentheses is recommended (to be order-made). In this case, specify by adding a code at the end of the standard model numbers as shown in the example below.

Ex.) CBY14-6SD32N10T-L A00 (T) A-40
 Standard Model Numbers A length : indicated by the dimension in A- parentheses
 Rod end special shape: Code A00 (T) is common to all bore diameters

**Single Rod, Mounting LD :
Foot Mounting**

Standard CBY14- *LD
With Switch CBY14L- *LD

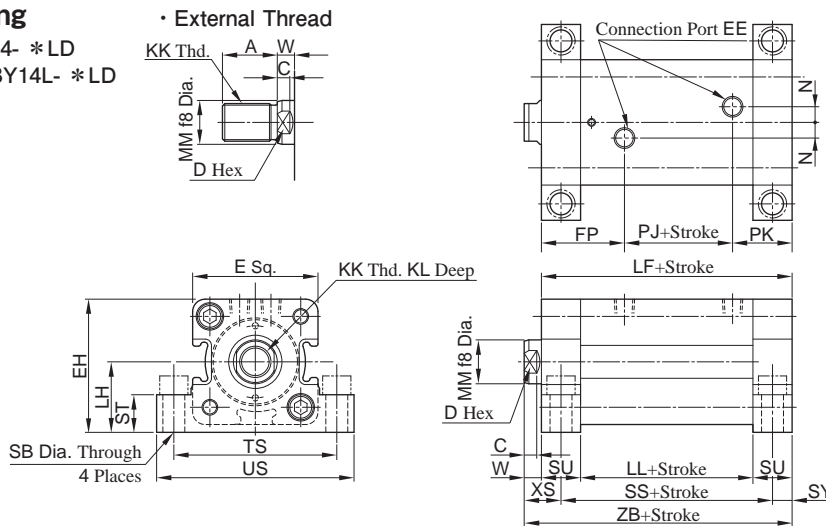

- Refer to "Dimensions with switch" for switch mounting. All dimensions are the same except for the switch mounting dimensions.
- Note: Socket head cap screws must be used for mounting bolts.
- The cylinder bore 100 has 3 grooves for switch mounting.

Bore	A	C	D	E	EE	EH	FP	KK		KL	LF	LH	LL	MM	N	PJ	PK	SB	SS	ST	SU	SY	TS	US	W	XS	ZB	Mass kg		
								Internal Thread	External Thread																			Basic Int. Thd.	Add. Unit St. 1 mm	Add. Ext. Thd.
32	25 (40)	7	14	62	Rc1/4	66	48	M12×1.75	M16×1.5	15	94	35±0.15	54	18	10	14	32	9	74	16	20	10	79	94	10	20	104	1.73	0.009	0.05
40	30 (45)	7	19	70	Rc1/4	72.5	47	M16×2	M20×1.5	20	95	37.5±0.15	55	22	10	16	32	11	75	20	20	10	90	108	10	20	105	2.27	0.011	0.10
50	35 (50)	8	24	80	Rc1/4	85	53	M20×2.5	M24×1.5	24	110	45±0.15	60	28	10	19	38	14	85	24	25	12.5	104	126	11	23.5	121	3.71	0.015	0.18
63	45 (60)	9	30	94	Rc1/4	97	55	M27×3	M30×1.5	33	117	50±0.15	67	36	10	24	38	16	92	30	25	12.5	121	146	13	25.5	130	5.30	0.021	0.40
80	60 (80)	14	41	114	Rc3/8	117	65	M30×3.5	M39×1.5	36	138	60±0.25	78	45	15	25	48	18	108	35	30	15	144	172	17	32	155	9.58	0.031	0.76
100	75 (95)	22	50	138	Rc3/8	140	77	M39×4	M48×1.5	45	166	71±0.25	96	56	15	26	63	22	131	43	35	17.5	174	208	26	43.5	192	17.02	0.046	1.50

Note: When using lock nuts, dimension A in parentheses is recommended (to be order-made). In this case, specify by adding a code to the end of the standard model numbers, referring to the "Basic Type" above.

Single Rod, Mounting FA : Rod Flange

Standard CBY14- *FA
With Switch CBY14L- *FA

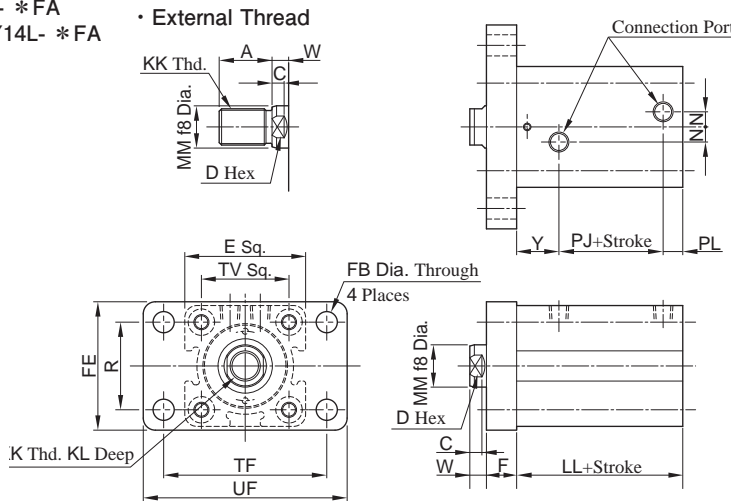

- Refer to "Dimensions with switch" for switch mounting. All dimensions are the same except for the switch mounting dimensions.
- The cylinder bore 100 has 3 grooves for switch mounting.

Bore	A	C	D	E	EE	F	FB	FE	KK		KL	LL	MM	N	PJ	PL	R	TF	TV	UF	W	Y	Mass kg		
									Internal Thread	External Thread													Basic Int. Thd.	Add. Unit St. 1 mm	Add. Ext. Thd.
32	25 (40)	7	14	62	Rc1/4	15	6.6	62	M12×1.75	M16×1.5	15	54	18	10	14	12	40	80	47	95	10	28	1.26	0.009	0.05
40	30 (45)	7	19	70	Rc1/4	20	11	70	M16×2	M20×1.5	20	55	22	10	16	12	46	96	52	118	10	27	2.01	0.011	0.10
50	35 (50)	8	24	80	Rc1/4	20	14	85	M20×2.5	M24×1.5	24	60	28	10	19	13	58	108	58	135	11	28	2.88	0.015	0.18
63	45 (60)	9	30	94	Rc1/4	20	14	98	M27×3	M30×1.5	33	67	36	10	24	13	65	124	69	150	13	30	4.02	0.021	0.40
80	60 (80)	14	41	114	Rc3/8	25	18	118	M30×3.5	M39×1.5	36	78	45	15	25	18	87	154	86	185	17	35	7.49	0.031	0.76
100	75 (95)	22	50	138	Rc3/8	30	22	150	M39×4	M48×1.5	45	96	56	15	26	28	109	190	106	230	26	42	14.26	0.046	1.50

Note: When using lock nuts, dimension A in parentheses is recommended (to be order-made). In this case, specify by adding a code to the end of the standard model numbers, referring to the "Basic Type" of the previous page.

Single Rod, Mounting FB : Cap Flange

Standard CBY14- *FB
With Switch CBY14L- *FB

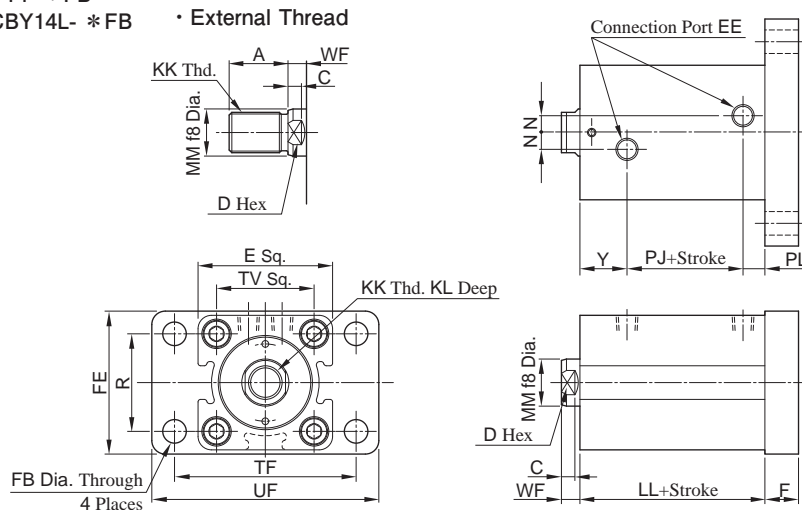

- Refer to "Dimensions with switch" for switch mounting. All dimensions are the same except for the switch mounting dimensions.
- The cylinder bore 100 has 3 grooves for switch mounting.

Bore	A	C	D	E	EE	F	FB	FE	KK		KL	LL	MM	N	PJ	PL	R	TF	TV	UF	WF	Y	Mass kg		
									Internal Thread	External Thread													Basic Int. Thd.	Add. Unit St. 1 mm	Add. Ext. Thd.
32	25 (40)	7	14	62	Rc1/4	15	6.6	62	M12×1.75	M16×1.5	15	54	18	10	14	12	40	80	47	95	10	28	1.26	0.009	0.05
40	30 (45)	7	19	70	Rc1/4	20	11	70	M16×2	M20×1.5	20	55	22	10	16	12	46	96	52	118	10	27	2.01	0.011	0.10
50	35 (50)	8	24	80	Rc1/4	20	14	85	M20×2.5	M24×1.5	24	60	28	10	19	13	58	108	58	135	11	28	2.88	0.015	0.18
63	45 (60)	9	30	94	Rc1/4	20	14	98	M27×3	M30×1.5	33	67	36	10	24	13	65	124	69	150	13	30	4.02	0.021	0.40
80	60 (80)	14	41	114	Rc3/8	25	18	118	M30×3.5	M39×1.5	36	78	45	15	25	18	87	154	86	185	17	35	7.49	0.031	0.76
100	75 (95)	22	50	138	Rc3/8	30	22	150	M39×4	M48×1.5	45	96	56	15	26	28	109	190	106	230	26	42	14.26	0.046	1.50

Note: When using lock nuts, dimension A in parentheses is recommended (to be order-made). In this case, specify by adding a code to the end of the standard model numbers, referring to the "Basic Type" of the previous page.

"CBY 14" Series

Double Rod, Mounting SD : Basic Type

Standard CBY14N- *SD
With Switch CBY14LN- *SD

• External Thread

• Thread of Port G

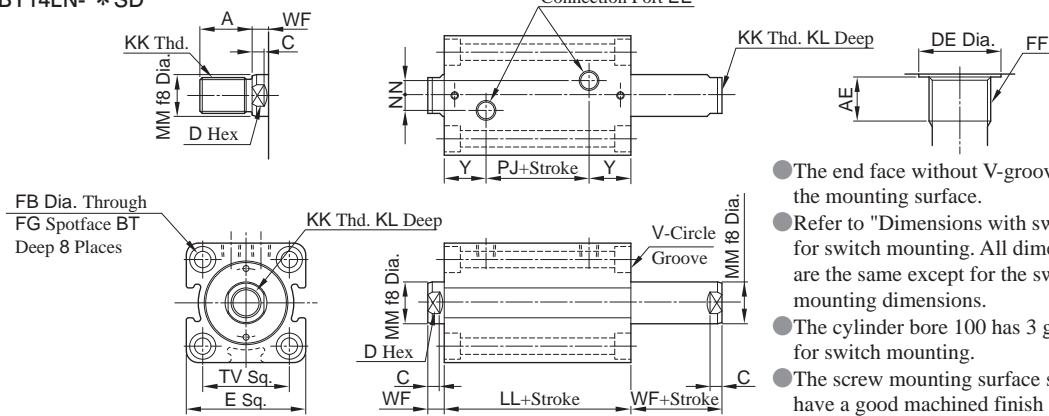

Bore	A	AE	BT	C	D	DE	E	EE	FB	FF	FG	KK		KL	LL	MM	N		PJ		TV	WF	Y		Mass kg		
												Internal Thread	External Thread				Rc Thd.	G Thd.	Rc Thd.	G Thd.			Rc Thd.	G Thd.	Basic Int. Thd.	Add. Unit St. 1 mm	Add. Ext. Thd.
32	25 (40)	8	6.5	7	14	17.2	62	Rc1/4	6.6	G1/8	11	M12×1.75	M16×1.5	15	72	18	10	10	16	16	47	10	28	28	1.01	0.011	0.10
40	30 (45)	8	8.6	7	19	17.2	70	Rc1/4	9	G1/8	14	M16×2	M20×1.5	20	72	22	10	10	18	18	52	10	27	27	1.30	0.014	0.20
50	35 (50)	12	10.8	8	24	21.5	80	Rc1/4	11	G1/4	17.5	M20×2.5	M24×1.5	24	75	28	10	14	19	19	58	11	28	28	1.90	0.020	0.36
63	45 (60)	12	13	9	30	21.5	94	Rc1/4	14	G1/4	20	M27×3	M30×1.5	33	82	36	10	16	22	22	69	13	30	30	2.89	0.029	0.80
80	60 (80)	12	15.2	14	41	21.5	114	Rc3/8	16	G1/4	23	M30×3.5	M39×1.5	36	95	45	15	19	25	23	86	17	35	36	5.36	0.043	1.52
100	75 (95)	12	17.5	22	50	25.5	138	Rc3/8	18	G3/8	26	M39×4	M48×1.5	45	108	56	15	18	24	24	106	26	42	42	9.83	0.065	3.00

Note: When using a lock nut, dimension A in parentheses is recommended (to be order-made). In this case, specify by adding a code at the end of the standard model numbers as shown in the example below. In this case, dimension A is the specified dimension only on the mounting side. If both sides need to be specified dimensions, please consult us separately.

Ex.) CBY14N-6SD32N10T-L A00 (T) A-40

Standard Model Numbers

A length : indicated by the dimension in A- parentheses

Rod end special shape: code A00 (T) is common to all bore diameters

Double Rod, Mounting LD : Foot Mounting

Standard CBY14N- *LD

With Switch CBY14LN- *LD

• External Thread

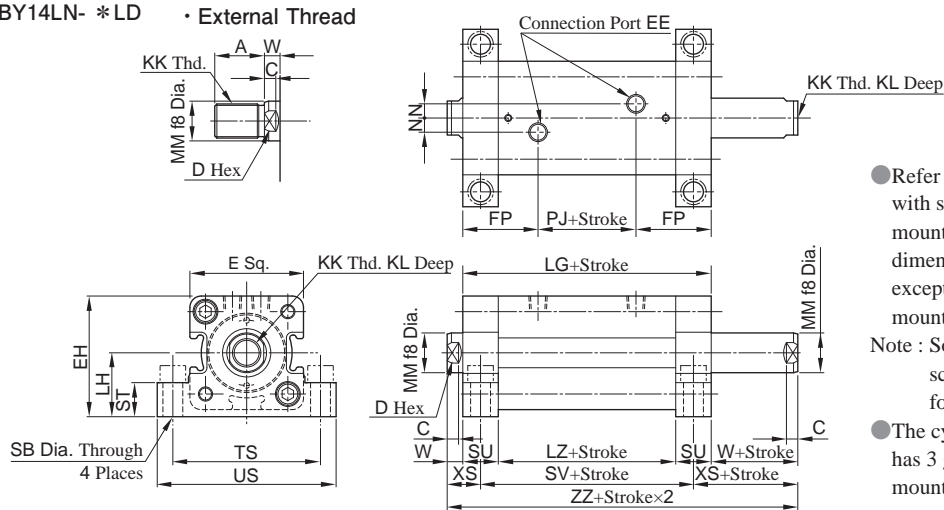

Bore	A	C	D	E	EE	EH	FP	KK		KL	LG	LH	LZ	MM	N	PJ	SB	ST	SU	SV	TS	US	W	XS	ZZ	Mass kg		
								Internal Thread	External Thread																	Basic Int. Thd.	Add. Unit St. 1 mm	Add. Ext. Thd.
32	25 (40)	7	14	62	Rc1/4	66	48	M12×1.75	M16×1.5	15	112	35±0.15	72	18	10	16	9	16	20	92	79	94	10	20	132	2.1	0.011	0.10
40	30 (45)	7	19	70	Rc1/4	72.5	47	M16×2	M20×1.5	20	112	37.5±0.15	72	22	10	18	11	20	20	92	90	108	10	20	132	2.72	0.014	0.20
50	35 (50)	8	24	80	Rc1/4	85	53	M20×2.5	M24×1.5	24	125	45±0.15	75	28	10	19	14	24	25	100	104	126	11	23.5	147	4.33	0.020	0.36
63	45 (60)	9	30	94	Rc1/4	97	55	M27×3	M30×1.5	33	132	50±0.15	82	36	10	22	16	30	25	107	121	146	13	25.5	158	6.19	0.029	0.80
80	60 (80)	14	41	114	Rc3/8	117	65	M30×3.5	M39×1.5	36	155	60±0.15	95	45	15	25	18	35	30	125	144	172	17	32	189	11.22	0.043	1.52
100	75 (95)	22	50	138	Rc3/8	140	77	M39×4	M48×1.5	45	178	71±0.15	108	56	15	24	22	43	35	143	174	208	26	43.5	230	19.82	0.065	3.00

Note: When using lock nuts, dimension A in parentheses is recommended (to be order-made). In this case, specify by adding a code to the end of the standard model numbers, referring to the "Basic Type" above.

Double Rod, Mounting FA : Rod Flange

Standrd CBY14N- *FA
With Switch CBY14LN- *FA

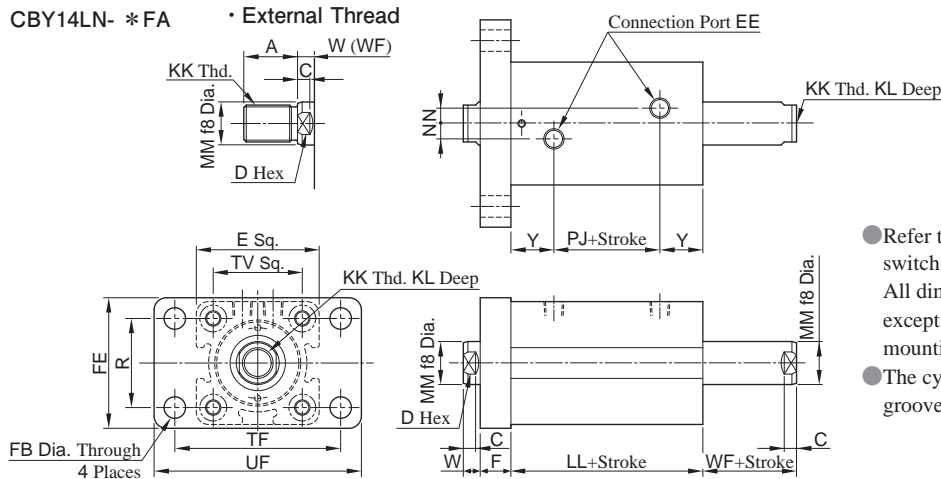

- Refer to "Dimensions with switch" for switch mounting. All dimensions are the same except for the switch mounting dimensions.
- The cylinder bore 100 has 3 grooves for switch mounting.

Bore	A	C	D	E	EE	F	FB	FE	KK		KL	LL	MM	N	PJ	R	TF	TV	UF	W	WF	Y	Mass kg		
									Internal Thread	External Thread													Basic Int. Thd.	Add. Unit St. 1 mm	Add. Ext. Thd.
32	25 (40)	7	14	62	Rc1/4	15	6.6	62	M12×1.75	M16×1.5	15	72	18	10	16	40	80	47	95	10	10	28	1.63	0.011	0.10
40	30 (45)	7	19	70	Rc1/4	20	11	70	M16×2	M20×1.5	20	72	22	10	18	46	96	52	118	10	10	27	2.46	0.014	0.20
50	35 (50)	8	24	80	Rc1/4	20	14	85	M20×2.5	M24×1.5	24	75	28	10	19	58	108	58	135	11	11	28	3.50	0.020	0.36
63	45 (60)	9	30	94	Rc1/4	20	14	98	M27×3	M30×1.5	33	82	36	10	22	65	124	69	150	13	13	30	4.91	0.029	0.80
80	60 (80)	14	41	114	Rc3/8	25	18	118	M30×3.5	M39×1.5	36	95	45	15	25	87	154	86	185	17	17	35	9.13	0.043	1.52
100	75 (95)	22	50	138	Rc3/8	30	22	150	M39×4	M48×1.5	45	108	56	15	24	109	190	106	230	26	26	42	17.06	0.065	3.00

Note: When using lock nuts, dimension A in parentheses is recommended (to be order-made). In this case, specify by adding a code to the end of the standard model numbers, referring to the "Basic Type" of the previous page.

With Switch : CBY14L(N)

Single Rod

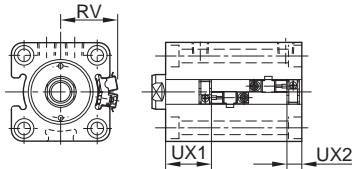

- The cylinder bore 100 has 3 grooves for switch mounting.

Double Rod

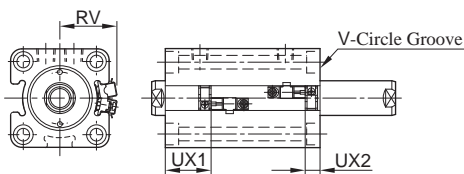

- The cylinder bore of 100 has 3 grooves for switch mounting.
- The one without V-circle groove on the end face is UX1.

Dimensions

Unit : mm

Code	RV	UX1		UX2	
		Single Rod	Double Rod	Single Rod	Double Rod
32	37	19	19	17	35
40	41	20	20	17	34
50	46	22	22	20	35
63	54	24	24	25	40
80	63	30	30	30	47
100	75	36	36	42	53

Operating Range and Diff. of Response

Unit : mm

Bore	Contact		Contactless	
	Operating range	Diff. of Response	Operating range	Diff. of Response
32				
40				
50	10 - 17	2 or less	4 - 8	1 or less
63				
80				
100	6 - 14	2 or less	6 - 9	1 or less

Note: UX dimensions are for reference only. For details, refer to minimum stroke for switch mounting on page J-81.

Adjust the Switch Detection Position

Tightening torque for bracket fixing screw :
Approx. 0.4Nm

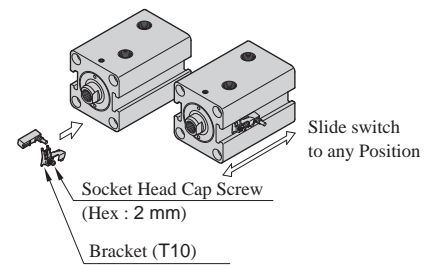

1. Loosen the bracket fixing screw and fit the bracket into the center of the switch.
2. With the switch and bracket combined, insert them into the switch mounting area of the cylinder body.
3. Slide the switch to the desired position. The detection is most stable when mounted in the center of the operating range.
4. For cylinder stroke end detection, install to UX dimension (optimum setting position).
5. Tighten the bracket fixing screw after sliding it to the detection position.

Note: Incorrect tightening torque may cause misalignment of the switch or damage to the switch itself.

Lock Nut

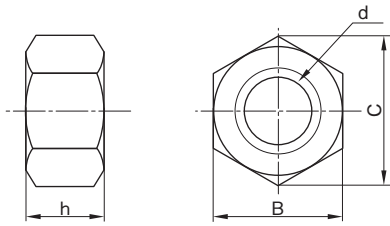

Dimensions

Bore	Parts Numbers	d	B	C	h
32	LNH-16F-H	M16×1.5	22	25.4	10
40	LNH-20F-H	M20×1.5	27	31.2	12
50	LNH-24F-H	M24×1.5	32	37.0	14
63	LNH-30F-H	M30×1.5	41	47.3	17
80	LNH-39F-H	M39×1.5	55	68.5	20
100	LNH-48F-H	M48×1.5	70	80.8	26

Structure Diagram / Packing List

Single Rod Standard Type : CBY14

● Bore 32

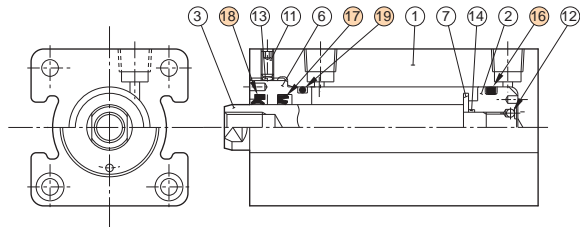

Single Rod with Switch Type : CBY14L

● Bore 32

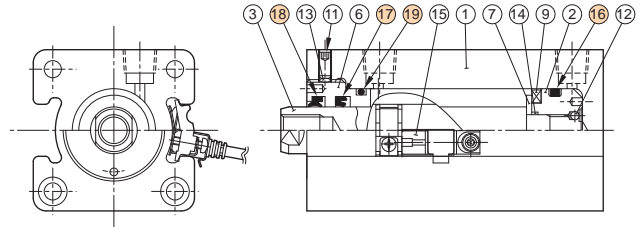

● Bore 40 - 100

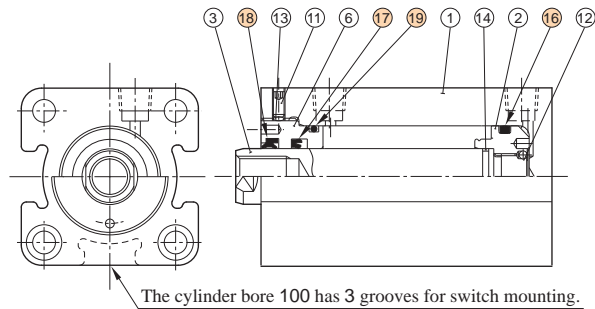

● Bore 40 - 100

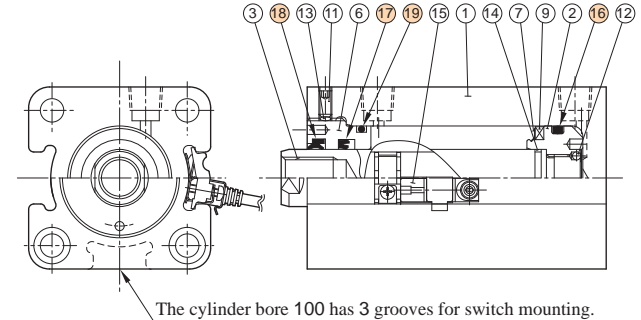

Packing Material "6" Hydrogenated Nitrile Rubber / CBY14 (L) -6

Item	Name	Material	Q'ty	Parts Numbers					
				32	40	50	63	80	100
16	Piston Packing	Hydrogenated Nitrile Rubber	1	NCHY-32	NCHY-40	NCHY-50	NCHY-63	NCHY-80	NCHY-100
17	Rod Packing	Hydrogenated Nitrile Rubber	1	UHR-18	UHR-22	UHR-28A	UHR-36	UHR-45	UHR-56
18	Dust Seal	Hydrogenated Nitrile Rubber	1	DHS-18	DHS-22	DHS-28	DHS-36	DHS-45	DHS-56
19	O-Ring for Bush★	Hydrogenated Nitrile Rubber	1	G-25	G-35	G-45	G-58 (Special)	G-75	G-95

★O-ring is OR HNBR-90 G**-N. O-ring for cylinder bore 63 is a special size.

Packing Material "3" Fluoro Rubber / CBY14 (L) -3

Item	Name	Material	Q'ty	Parts Numbers					
				32	40	50	63	80	100
16	Piston Packing	Fluoro Rubber	1	P-26	P-34	P-44	P-53	P-70	P-90
17	Rod Packing	Fluoro Rubber	1	UHR-18	UHR-22	UHR-28A	UHR-36	UHR-45	UHR-56
18	Dust Seal	Fluoro Rubber	1	DHS-18	DHS-22	DHS-28	DHS-36	DHS-45	DHS-56
19	O-Ring for Bush★	Fluoro Rubber	1	G-25	G-35	G-45	G-58 (Special)	G-75	G-95

★O-ring is OR FKM-90 G * *-N. O-ring for cylinder bore 63 is a special size.

Structure Diagram / Packing List

Double Rod Standard Type : CBY14N

● Bore 32

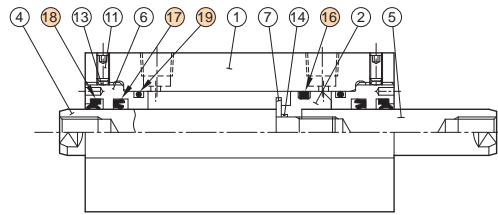
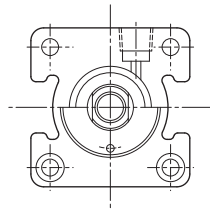

● Bore 40 - 100

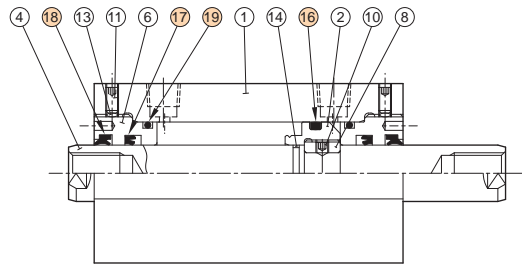
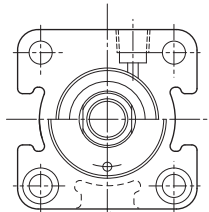

The cylinder bore 100 has 3 grooves for switch mounting.

Double Rod with Switch Type : CBY14LN

● Bore 32

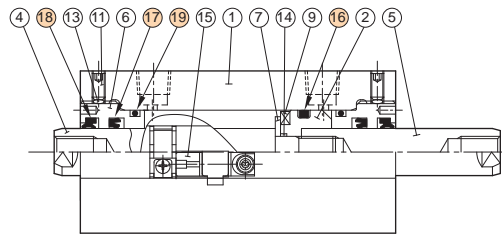
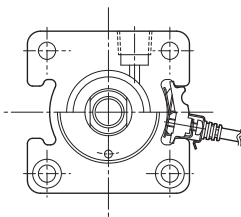

● Bore 40 - 100

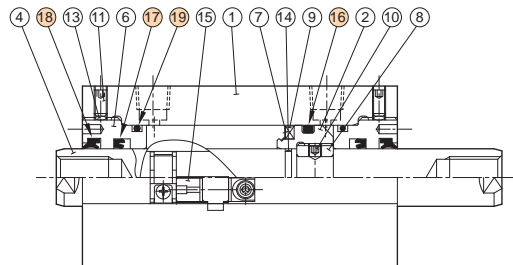
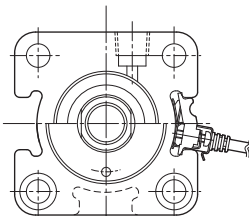

The cylinder bore 100 has 3 grooves for switch mounting.

■ Packing Material "6" Hydrogenated Nitrile Rubber / CBY14 (L) N-6

Item	Name	Material	Q'ty	Parts Numbers					
				32	40	50	63	80	100
16	Piston Packing	Hydrogenated Nitrile Rubber	1	NCHY-32	NCHY-40	NCHY-50	NCHY-63	NCHY-80	NCHY-100
17	Rod Packing	Hydrogenated Nitrile Rubber	2	UHR-18	UHR-22	UHR-28A	UHR-36	UHR-45	UHR-56
18	Dust Seal	Hydrogenated Nitrile Rubber	2	DHS-18	DHS-22	DHS-28	DHS-36	DHS-45	DHS-56
19	O-Ring for Bush★	Hydrogenated Nitrile Rubber	2	G-25	G-35	G-45	G-58 (Special)	G-75	G-95

★O-ring is OR HNBR-90 G * *-N. O-ring for cylinder bore 63 is a special size.

■ Packing Material "3" Fluoro Rubber / CBY14 (L) N-3

Item	Name	Material	Q'ty	Parts Numbers					
				32	40	50	63	80	100
16	Piston Packing	Fluoro Rubber	1	P-26	P-34	P-44	P-53	P-70	P-90
17	Rod Packing	Fluoro Rubber	2	UHR-18	UHR-22	UHR-28A	UHR-36	UHR-45	UHR-56
18	Dust Seal	Fluoro Rubber	2	DHS-18	DHS-22	DHS-28	DHS-36	DHS-45	DHS-56
19	O-Ring for Bush★	Fluoro Rubber	2	G-25	G-35	G-45	G-58 (Special)	G-75	G-95

★O-ring is OR FKM-90 G * *-N. O-ring for cylinder bore 63 is a special size.

"CBY 14" Series

"CJT70PS/140PS" Series Position Sensing Type Hydraulic Cylinders

Magnetostrictive mechanism provides highly accurate position detection.

High Accuracy

The magnetostrictive position sensor enables high-accuracy detection of absolute position. Industrial displacement sensors that apply the magnetostrictive phenomenon caused by the Wiedemann effect are used as position sensors.

Various Output Methods

Either analog or digital output can be selected to accommodate various outputs of machinery equipment.

Easy Replacement

The CJT70PS/140PS Series Position Sensing Type Hydraulic Cylinders are interchangeable with the CJT 70/140 Series standard hydraulic cylinders, allowing easy replaceable in machinery equipment. (Except for the mounting types SD/LA/LB)

Amplifier built-in type is available

The GYcAT type has an amplifier built into the sensor head, so a high-accuracy analog output can be obtained simply by supplying a 24 V DC power supply.

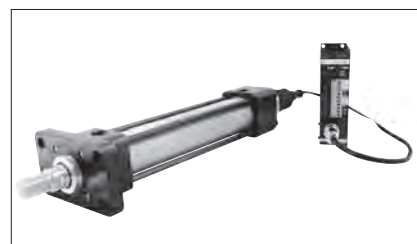

Specifications

Model Numbers	CJT ¹⁴⁰ ₇₀ PS- * * * *N- *N* - * * * -10	
Rod Size	B	C
Cylinder Bore mm	50, 63, 80, 100, 125, 140, 150, 160, 180	100, 125, 140, 150, 160, 180
Nominal Pressure MPa	7/14	
Maximum Stroke mm	Bore 50 : 1200 Bore 100,125,140 : 1500	Bore 63,80 : 1300 Bore 150,160,180 : 2000
Minimum Stroke mm	15	
Minimum Resolution	1 μm	
Linearity	0.01 %	
Repetitive Precision	0.001 %	
Applicable Standard	Compliant with former JIS B8354	

Mounting Type

Code	Name	Illustration of Mounting Type	Code	Name	Illustration of Mounting Type
SD	Basic Type		FY	Flange Type	
LA	Foot Mounting (For 7MPa Only)		FC		
LB			TA	Intermediate Trunnion	
FA	Flange Type		TC		

— Please consult us separately for details on position sensing type hydraulic cylinders. —

Mini Series Hydraulic Cylinders

The Mini Series Hydraulic Cylinders are hydraulic cylinders developed to meet the needs for miniaturization, such as for space-saving small machine tools and medical equipment. A wide range of mounting types and other variations are available to suit your application.

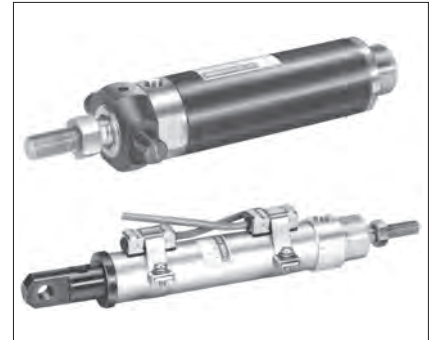

Graphic Symbols

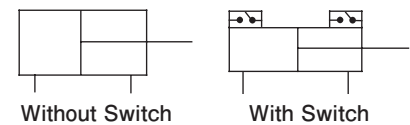

Specifications

Descriptions	Model Numbers	SW-1 * * * *	KM * - * * * * *	KW - * * * * *
		- * * - * - * - * -00	- * * - * - * - * -01	- * * - * - * - * -01
Cylinder Bore	mm	20, 25, 30		
Mounting Type		ST, LB, FA, CA, TA, TB		
Operating Maximum Pressure	MPa	3.5	7	
Allowable Surge Pressure ^{★1}	MPa	5.3	10.5	
Pressure Proof (inspection pressure)	MPa	5.3	10.5	
Minimum Working Pressure	MPa	0.3	0.3 or less ^{★3}	
Ambient Temperature (oil temperature)		-10 - +60	-10 - +80	-10 - +60
Operating Maximum Speed		300 mm/s		
Operating Minimum Speed		10 mm/s		
Maximum Cylinder Stroke ^{★2}		300 mm		

★1. The pressure generated in the cylinder due to load inertia should be within the above allowable surge pressure.

★2. It may be limited to even lower values from the buckling strength. Please consult us for details.

★3. The minimum working pressure for double rod types is 0.5 MPa or less.

По вопросам продаж и поддержки обращайтесь:

Алматы (7273)495-231
 Ангарск (3955)60-70-56
 Архангельск (8182)63-90-72
 Астрахань (8512)99-46-04
 Барнаул (3852)73-04-60
 Белгород (4722)40-23-64
 Благовещенск (4162)22-76-07
 Брянск (4832)59-03-52
 Владивосток (423)249-28-31
 Владикавказ (8672)28-90-48
 Владимир (4922)49-43-18
 Волгоград (844)278-03-48
 Вологда (8172)26-41-59
 Воронеж (473)204-51-73
 Екатеринбург (343)384-55-89
 Иваново (4932)77-34-06
 Ижевск (3412)26-03-58
 Иркутск (395)279-98-46
 Казань (843)206-01-48

Калининград (4012)72-03-81
 Калуга (4842)92-23-67
 Кемерово (3842)65-04-62
 Киров (8332)68-02-04
 Коломна (4966)23-41-49
 Кострома (4942)77-07-48
 Краснодар (861)203-40-90
 Красноярск (391)204-63-61
 Курган (3522)50-90-47
 Курск (4712)77-13-04
 Липецк (4742)52-20-81
 Магнитогорск (3519)55-03-13
 Москва (495)268-04-70
 Мурманск (8152)59-64-93
 Набережные Челны (8552)20-53-41
 Нижний Новгород (831)429-08-12
 Новокузнецк (3843)20-46-81
 Новосибирск (383)227-86-73
 Ноябрьск (3496)41-32-12

Омск (3812)21-46-40
 Орел (4862)44-53-42
 Оренбург (3532)37-68-04
 Пенза (8412)22-31-16
 Пермь (342)205-81-47
 Петрозаводск (8142)55-98-37
 Псков (8112)59-10-37
 Ростов-на-Дону (863)308-18-15
 Рязань (4912)46-61-64
 Самара (846)206-03-16
 Санкт-Петербург (812)309-46-40
 Саранск (8342)22-96-24
 Саратов (845)249-38-78
 Севастополь (8692)22-31-93
 Симферополь (3652)67-13-56
 Смоленск (4812)29-41-54
 Сочи (862)225-72-31
 Ставрополь (8652)20-65-13
 Сургут (3462)77-98-35

Сыктывкар (8212)25-95-17
 Тамбов (4752)50-40-97
 Тверь (4822)63-31-35
 Тольятти (8482)63-91-07
 Томск (3822)98-41-53
 Тула (4872)33-79-87
 Тюмень (3452)66-21-18
 Улан-Удэ (3012)59-97-51
 Ульяновск (8422)24-23-59
 Уфа (347)229-48-12
 Хабаровск (4212)92-98-04
 Чебоксары (8352)28-53-07
 Челябинск (351)202-03-61
 Череповец (8202)49-02-64
 Чита (3022)38-34-83
 Якутск (4112)23-90-97
 Ярославль (4852)69-52-93