

Алматы (7273)495-231
 Ангарск (3955)60-70-56
 Архангельск (8182)63-90-72
 Астрахань (8512)99-46-04
 Барнаул (3852)73-04-60
 Белгород (4722)40-23-64
 Благовещенск (4162)22-76-07
 Брянск (4832)59-03-52
 Владивосток (423)249-28-31
 Владикавказ (8672)28-90-48
 Владимир (4922)49-43-18
 Волгоград (844)278-03-48
 Вологда (8172)26-41-59
 Воронеж (473)204-51-73
 Екатеринбург (343)384-55-89

Иваново (4932)77-34-06
 Ижевск (3412)26-03-58
 Иркутск (395)279-98-46
 Казань (843)206-01-48
 Калининград (4012)72-03-81
 Калуга (4842)92-23-67
 Кемерово (3842)65-04-62
 Киров (8332)68-02-04
 Коломна (4966)23-41-49
 Кострома (4942)77-07-48
 Краснодар (861)203-40-90
 Красноярск (391)204-63-61
 Курган (3522)50-90-47
 Курск (4712)77-13-04
 Липецк (4742)52-20-81

Магнитогорск (3519)55-03-13
 Москва (495)268-04-70
 Мурманск (8152)59-64-93
 Набережные Челны (8552)20-53-41
 Нижний Новгород (831)429-08-12
 Новокузнецк (3843)20-46-81
 Новосибирск (383)227-86-73
 Ноябрьск (3496)41-32-12
 Омск (3812)21-46-40
 Орел (4862)44-53-42
 Оренбург (3532)37-68-04
 Пенза (8412)22-31-16
 Пермь (342)205-81-47
 Петропавловск (8142)55-98-37
 Псков (8112)59-10-37

Ростов-на-Дону (863)308-18-15
 Рязань (4912)46-61-64
 Самара (846)206-03-16
 Санкт-Петербург (812)309-46-40
 Саранск (8342)22-96-24
 Саратов (845)249-38-78
 Севастополь (8692)22-31-93
 Симферополь (3652)67-13-56
 Смоленск (4812)29-41-54
 Сочи (862)225-72-31
 Ставрополь (8652)20-65-13
 Сургут (3462)77-98-35
 Сыктывкар (8212)25-95-17
 Тамбов (4752)50-40-97
 Тверь (4822)63-31-35

Тольятти (8482)63-91-07
 Томск (3822)98-41-53
 Тула (4872)33-79-87
 Тюмень (3452)66-21-18
 Улан-Удэ (3012)59-97-51
 Ульяновск (8422)24-23-59
 Уфа (347)229-48-12
 Хабаровск (4212)92-98-04
 Чебоксары (8352)28-53-07
 Челябинск (351)202-03-61
 Череповец (8202)49-02-64
 Чита (3022)38-34-83
 Якутск (4112)23-90-97
 Ярославль (4852)69-52-93

Россия +7(495)268-04-70

Казахстан +7(7172)727-132

Киргизия +996(312)96-26-47

yne@nt-rt.ru || <https://yuken.nt-rt.ru>

Proportional Electro-Hydraulic Relief Valves

This valve is derived by combining a small, high-performance 1/8 proportional electro-hydraulic pilot relief valve with a specially developed low-noise relief valve.

With this valve, it is possible to regulate the system pressure in proportion to the input current. Note that this valve is used in conjunction with the applicable power amplifier.

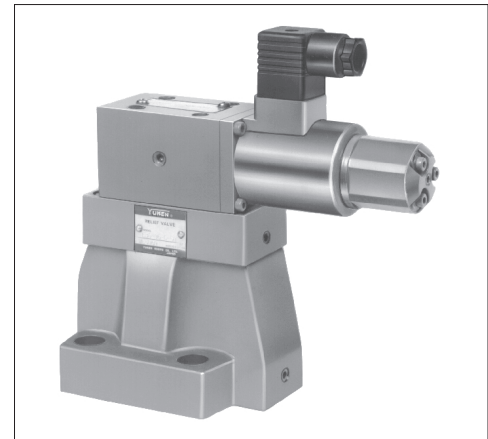

Specifications

Model Numbers		EBG-03	EBG-06	EBG-10
Descriptions				
Max. Operating Pres.	MPa	24.5	24.5	24.5
Max. Flow	L/min	100	200	400
Min. Flow	L/min	3	3	3
Pressure Adjustment Range	MPa	Refer to Model Number Designation		
Rated Current	mA	C: 770	C: 750	C: 730
		H: 820	H: 800	H: 780
Coil Resistance	Ω	10	10	10
Hysteresis		3% or less	3% or less	3% or less
Repeatability		1% or less	1% or less	1% or less
Approx. Mass	kg	5.6	6.3	10

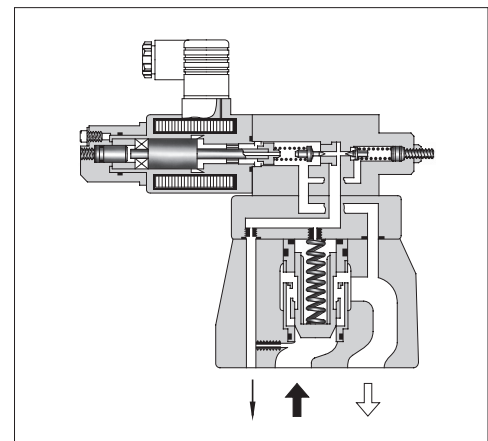

Graphic Symbols

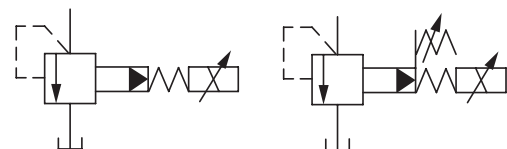

Without Safety Valve

With Safety Valve

Model Number Designation

EB	G	-03	-C	-T	-51
Series Number	Type of Mounting	Valve Size	Pressure Adj. Range MPa	Safety Valve	Design Number
EB: Proportional Electro-Hydraulic Relief Valve	G: Sub-Plate Mounting	03	C: * -15.7* ¹ H: * -24.5* ¹	None: With Safety Valve T: Without Safety Valve	51
		06			
		10			

*1. Min. adjustment pressure shall be referred to the curves on page H-103.

Accessories

Mounting Bolts

Valve Model Numbers	Socket Head Cap Screw	Qty.
EBG-03	M12 × 40 L	4
EBG-06	M16 × 50 L	4
EBG-10	M20 × 60 L	4

Applicable Power Amplifiers

For stable performance, it is recommended that Yuken's applicable power amplifiers be used (for details see pages H-173, H-177 and H-183).

- Model Numbers : AME-D-10- *-20 SK1022- *- *-11
- AME-D2-1010-11 SK1015-11 (For DC power supply)
- AMN-D-10 (For DC power supply)

Sub-Plates

Valve Model Numbers	Sub-Plate Model Numbers	Thread Size Rc	Approx. Mass kg
EBG-03	BGM-03-20	3/8	2.4
	BGM-03X-20	1/2	3.1
EBG-06	BGM-06-20	3/4	4.7
	BGM-06X-20	1	5.7
EBG-10	BGM-10-20	1-1/4	8.4
	BGM-10X-20	1-1/2	10.3

- Sub-plates are available. Specify the sub-plate model number from the table above. When sub-plates are not used, the mounting surface should have a good machined finish. ($\frac{1}{16}$)
- Sub-plates are those for pilot operated relief valves. For dimensions, see page H-18.

Instructions

A flow rate of 3 L/min or higher should be used to avoid preselected pressure instability.

Safety Valve

At shipment, the pressure of safety valves is set to the upper limits of the adjustable pressure ranges plus the extra as shown below.

Additional Pressures for Safety Valves at Shipment

Valve Model Numbers	Additional Pressures at Shipment MPa
EBG-03	2.0 (at 50 L/min)
EBG-06	3.5 (at 100 L/min)
EBG-10	4.0 (at 200 L/min)

In case where the upper limit of operating pressure is low or the upper limit of flow rate to be used is different from the specified maximum flow, please adjust and determine the setting pressure of the safety valve at the value calculated from the following formula.

Setting pressure = (Operating pressure upper limit) + (Additional pressure indicated below)

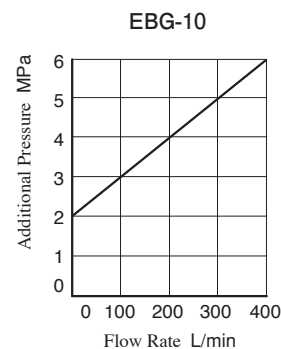
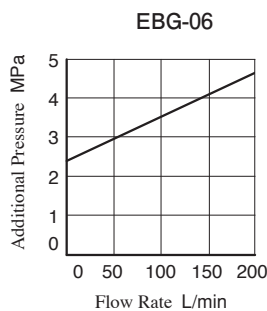
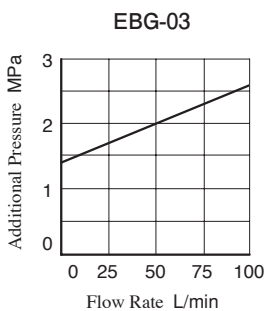

To lower the setting pressure, turn the safety valve pressure adjustment screw anti-clockwise. After adjustment, be sure to tighten the lock nut.



EBG-03 06 -*51

With Safety Valve

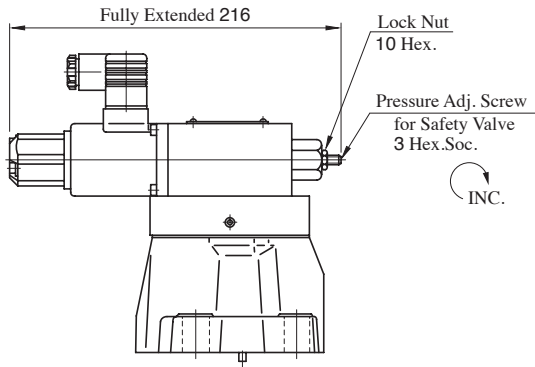

● For other dimensions, refer to the without safety valve.

Mounting Surface
 EBG-03 : ISO 6264-06-09-1-97
 EBG-06 : ISO 6264-08-13-1-97

EBG-03 06 -*T-51

Without Safety Valve

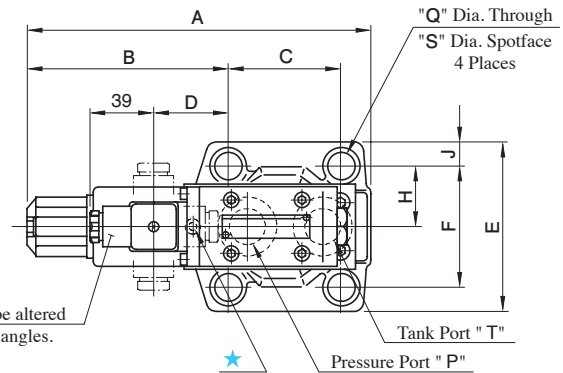

★ This port is not used. It is provided because of the common use of the body with the low-noise type pilot operated relief valve. On the sub-plate, plug the port which corresponds to this port.

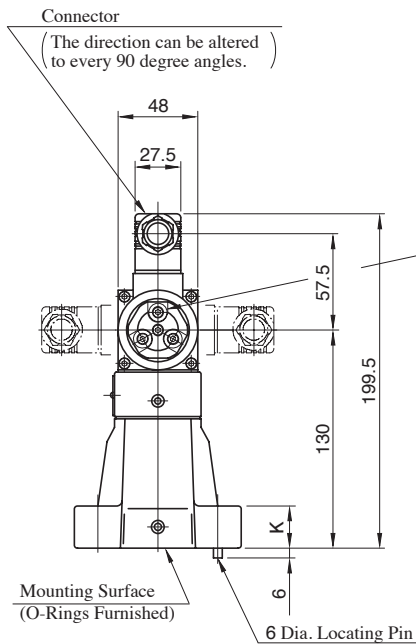

Cable Departure
 Cable Applicable:
 Outside Dia. ... 8-10 mm
 Conductor Area ... Not Exceeding 0.75-1.5 mm²

Model Numbers	Dimensions mm												
	A	B	C	D	E	F	H	J	K	L	N	Q	S
EBG-03	197.5	117.6	53.8	40.2	76	53.8	26.9	11.1	21.5	106	26.1	13.5	21
EBG-06	205.5	119.5	66.7	42.1	98	70	35	14	26	122	36	17.5	26

Note: For valve mounting surface dimensions, see the dimensional drawings of sub-plates (page H-18) in common use.

EBG-10- *-51

With Safety Valve

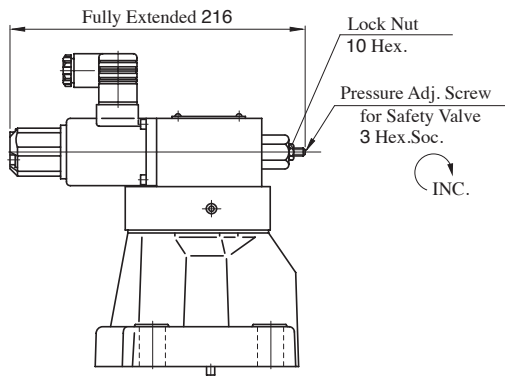

● For other dimensions, refer to the without safety valve.

EBG-10- *-T-51

Without Safety Valve

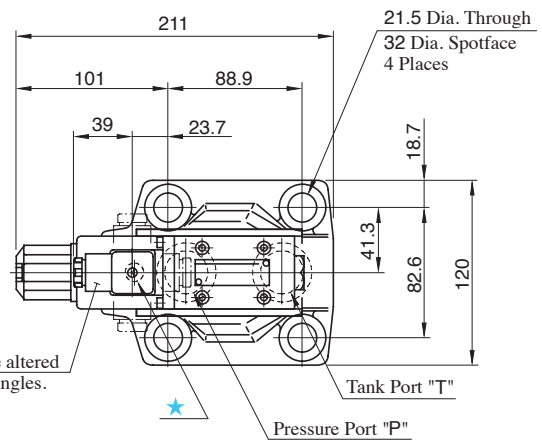

The direction can be altered to every 90 degree angles.

★ This port is not used. It is provided because of the common use of the body with the low-noise type pilot operated relief valve. On the sub-plate, plug the port which corresponds to this port.

Connector

(The direction can be altered to every 90 degree angles.)

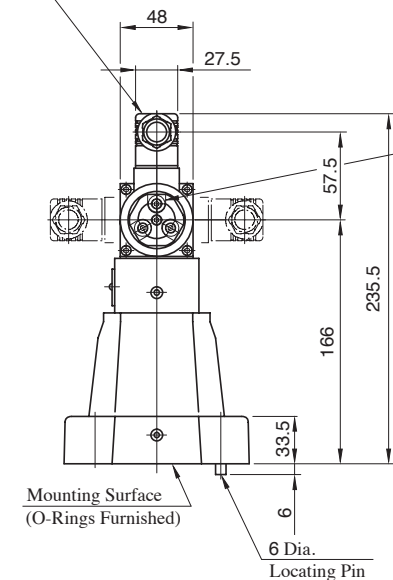

Cable Departure

Cable Applicable:
Outside Dia. ... 8-10 mm
Conductor Area
... Not Exceeding 0.75-1.5 mm²

Manual Pressure Adj. Screw 3 Hex.Soc.

INC.

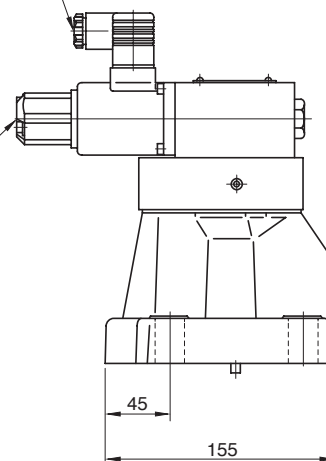

Note: For valve mounting surface dimensions, see the dimensional drawings of sub-plates (page H-18) in common use.



Min. Adjustment Pressure

Viscosity : 30 mm²/s

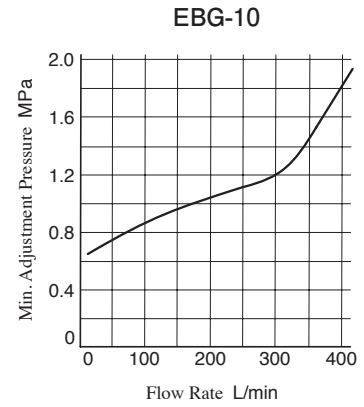
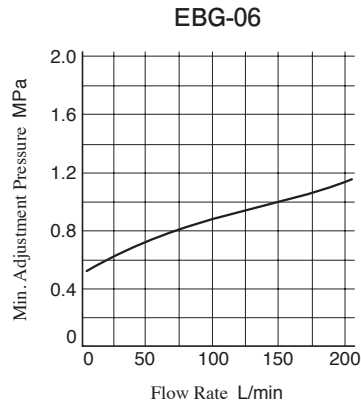
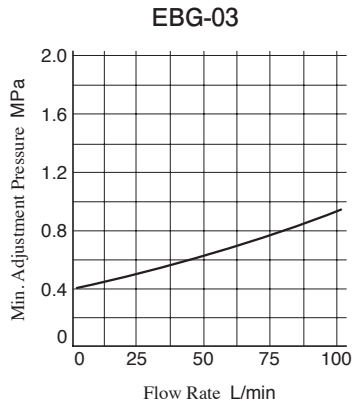

Step Response (Example)

These Characteristics have been obtained by measuring on each valve. Therefore, they may vary according to a hydraulic circuit to be used.

Trapped Oil Volume : 1 L
Viscosity : 30 mm²/s

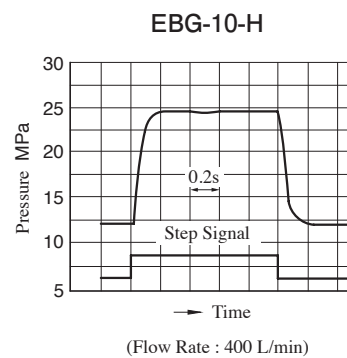
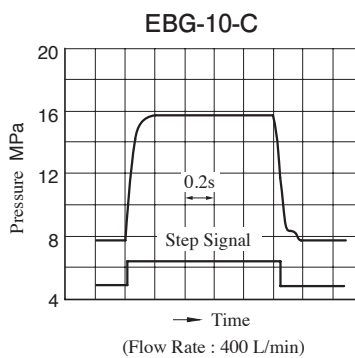
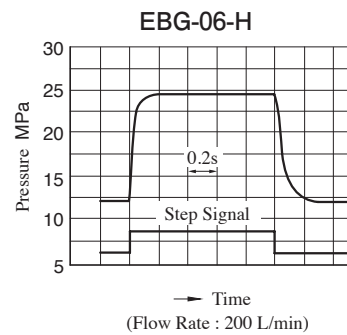
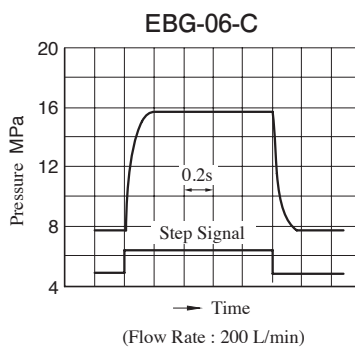
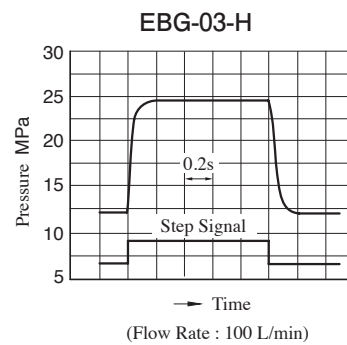
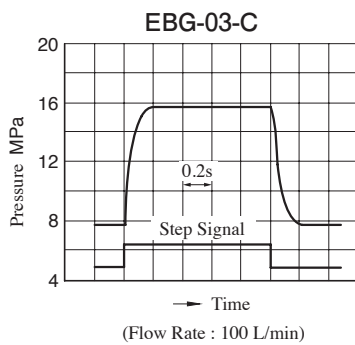

Input Current vs. Pressure

Viscosity : 30 mm²/s

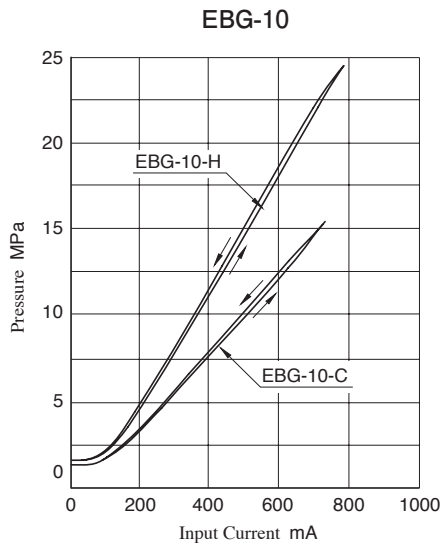
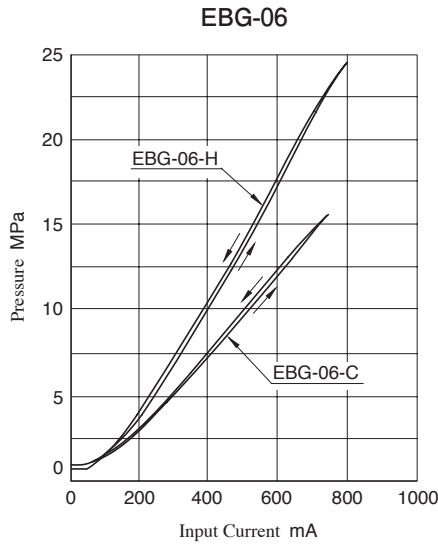
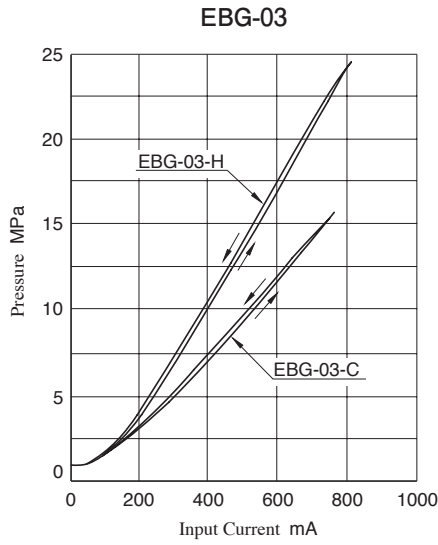

Frequency Response

Trapped Oil Volume : 1 L

Viscosity : 30 mm²/s

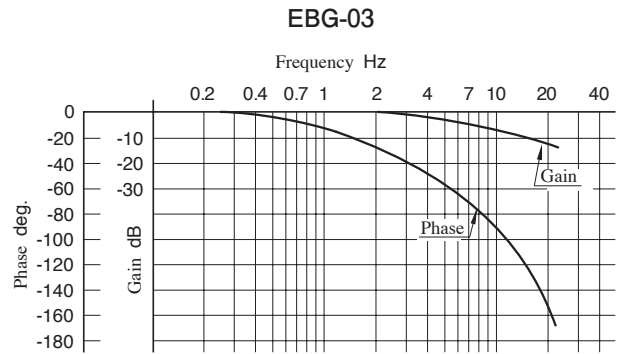

Pressure : 7.8 ± 1.6 MPa
Flow Rate : 100 L/min

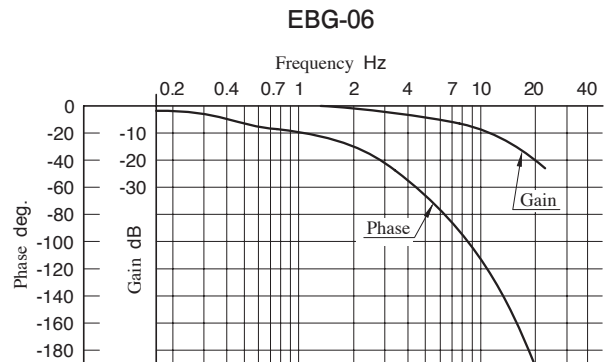

Pressure : 7.8 ± 1.6 MPa
Flow Rate : 200 L/min

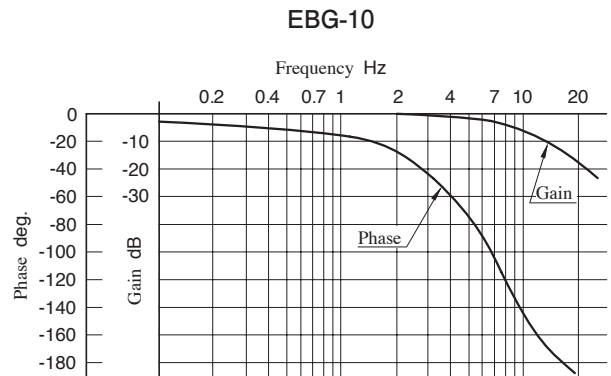

Pressure : 7.8 ± 1.6 MPa
Flow Rate : 400 L/min



Viscosity vs. Pressure

Oil : ISO VG 46

Flow Rate vs. Pressure

Viscosity : 30 mm²/s

EBG-03

Flow Rate : 100 L/min

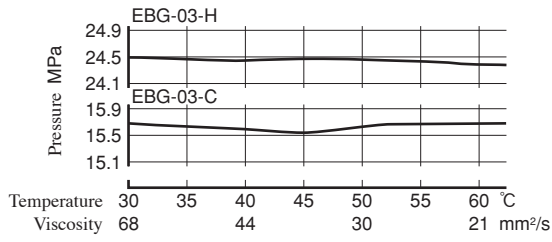

EBG-03

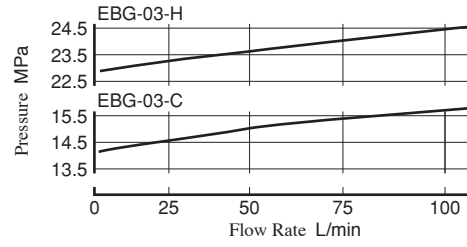

EBG-06

Flow Rate : 200 L/min

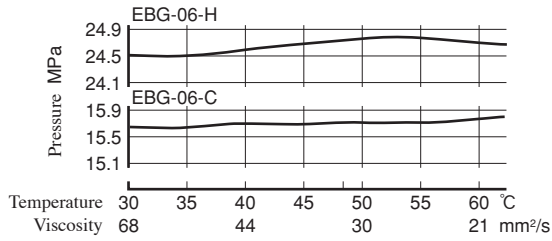

EBG-06

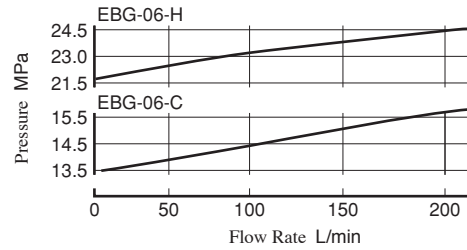

EBG-10

Flow Rate : 400 L/min

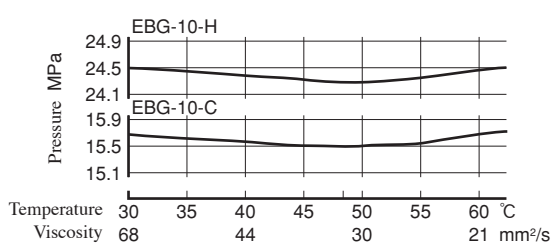

EBG-10

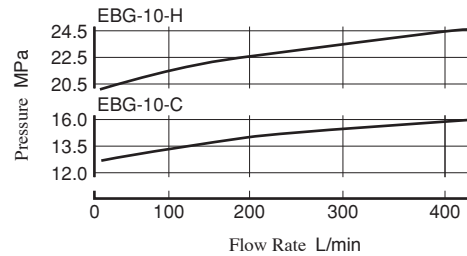

List of Seals and Pilot Valves

EBG-03, 06, 10

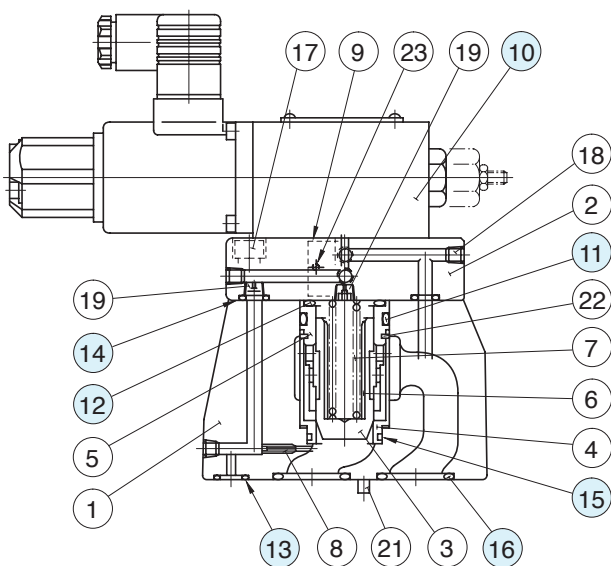

● Pilot Valves

Valve Model Numbers	⑩ Pilot Valve Model Numbers
EBG-03-C-51	EDG-01V-C-1-PNT09-51
EBG-03-H-51	EDG-01V-H-1-PNT09-51
EBG-03-C-T-51	EDG-01V-C-PNT09-51
EBG-03-H-T-51	EDG-01V-H-PNT09-51
EBG-06-C-51	EDG-01V-C-1-PNT10-51
EBG-06-H-51	EDG-01V-H-1-PNT10-51
EBG-06-C-T-51	EDG-01V-C-PNT10-51
EBG-06-H-T-51	EDG-01V-H-PNT10-51
EBG-10-C-51	EDG-01V-C-1-PNT11-5103
EBG-10-H-51	EDG-01V-H-1-PNT11-5103
EBG-10-C-T-51	EDG-01V-C-PNT11-5103
EBG-10-H-T-51	EDG-01V-H-PNT11-5103

Note: For the details of pilot valves, refer to "Pilot Relief Valves" on page H-97.

● List of Seals

Item	Name of Parts	Part Numbers			Qty.
		EBG-03	EBG-06	EBG-10	
11	O-Ring	OR NBR-90 P32-N	OR NBR-90 P32-N	OR NBR-90 P42-N	1
12	O-Ring	OR NBR-90 P28-N	OR NBR-90 P28-N	OR NBR-90 P28-N	1
13	O-Ring	OR NBR-90 P9-N	OR NBR-90 P11-N	OR NBR-90 P9-N	1
14	O-Ring	OR NBR-90 P9-N	OR NBR-90 P9-N	OR NBR-90 P9-N	2
15	O-Ring	AS568-024(NBR-90)	AS568-024(NBR-90)	AS568-128(NBR-90)	1
16	O-Ring	OR NBR-90 P18-N	OR NBR-90 P28-N	OR NBR-90 P32-N	2

Interchangeability between Current and New Design

EBG-03/06/10 series valves have changed model from 50 to 51 design in line with the model change of pilot valve (EDG-01).

Specifications and Characteristics

Input current-pressure characteristics differ between current and new design. Please inquire separately for details.

Other specifications remain unchanged.

Mounting Interchangeability

There is an interchangeability in the mounting dimensions, however, the outside shape and dimensions are changed as shown below due to pilot valve improvement and other modifications.

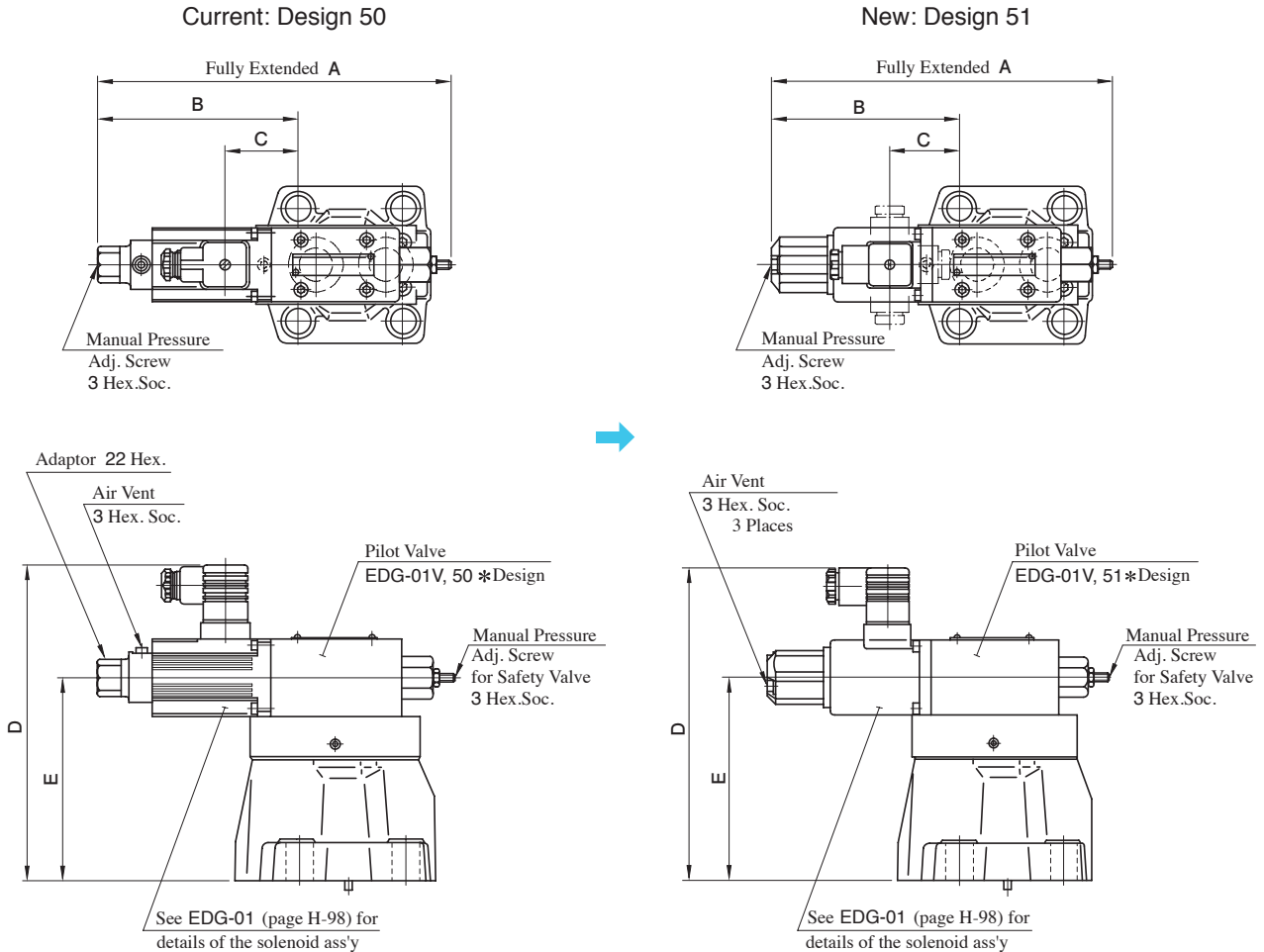

Model Numbers		A	B	C	D	E
Current	EBG-03- *- *-50	217	118.6	40.2	199.5	130
New	EBG-03- *- *-51	216	117.6	40.2		
Current	EBG-06- *- *-50	217	120.5	42.1	199.5	130
New	EBG-06- *- *-51	216	119.5	42.1		
Current	EBG-10- *- *-50	217	102	23.6	235.5	166
New	EBG-10- *- *-51	216	101	23.6		

По вопросам продаж и поддержки обращайтесь:

Алматы (7273)495-231
 Ангарск (3955)60-70-56
 Архангельск (8182)63-90-72
 Астрахань (8512)99-46-04
 Барнаул (3852)73-04-60
 Белгород (4722)40-23-64
 Благовещенск (4162)22-76-07
 Брянск (4832)59-03-52
 Владивосток (423)249-28-31
 Владикавказ (8672)28-90-48
 Владимир (4922)49-43-18
 Волгоград (844)278-03-48
 Вологда (8172)26-41-59
 Воронеж (473)204-51-73
 Екатеринбург (343)384-55-89

Иваново (4932)77-34-06
 Ижевск (3412)26-03-58
 Иркутск (395)279-98-46
 Казань (843)206-01-48
 Калининград (4012)72-03-81
 Калуга (4842)92-23-67
 Кемерово (3842)65-04-62
 Киров (8332)68-02-04
 Коломна (4966)23-41-49
 Кострома (4942)77-07-48
 Краснодар (861)203-40-90
 Красноярск (391)204-63-61
 Курган (3522)50-90-47
 Курск (4712)77-13-04
 Липецк (4742)52-20-81

Магнитогорск (3519)55-03-13
 Москва (495)268-04-70
 Мурманск (8152)59-64-93
 Набережные Челны (8552)20-53-41
 Нижний Новгород (831)429-08-12
 Новокузнецк (3843)20-46-81
 Новосибирск (383)227-86-73
 Ноябрьск (3496)41-32-12
 Омск (3812)21-46-40
 Орел (4862)44-53-42
 Оренбург (3532)37-68-04
 Пенза (8412)22-31-16
 Пермь (342)205-81-47
 Петрозаводск (8142)55-98-37
 Псков (8112)59-10-37

Ростов на Дону (863)308-18-15
 Рязань (4912)46-61-64
 Самара (846)206-03-16
 Санкт-Петербург (812)309-46-40
 Саранск (8342)22-96-24
 Саратов (845)249-38-78
 Севастополь (8692)22-31-93
 Симферополь (3652)67-13-56
 Смоленск (4812)29-41-54
 Сочи (862)225-72-31
 Ставрополь (8652)20-65-13
 Сургут (3462)77-98-35
 Сыктывкар (8212)25-95-17
 Тамбов (4752)50-40-97
 Тверь (4822)63-31-35

Тольятти (8482)63-91-07
 Томск (3822)98-41-53
 Тула (4872)33-79-87
 Тюмень (3452)66-21-18
 Улан-Удэ (3012)59-97-51
 Ульяновск (8422)24-23-59
 Уфа (347)229-48-12
 Хабаровск (4212)92-98-04
 Чебоксары (8352)28-53-07
 Челябинск (351)202-03-61
 Череповец (8202)49-02-64
 Чита (3022)38-34-83
 Якутск (4112)23-90-97
 Ярославль (4852)69-52-93

Россия +7(495)268-04-70

Казахстан +7(7172)727-132

Киргизия +996(312)96-26-47

yne@nt-rt.ru || <https://yuken.nt-rt.ru>