

# "CJT 21 MPa" Series Hydraulic Cylinders

YUKEN's "CJT 21 MPa" Series Hydraulic Cylinders are higher nominal pressure for use in a wide range of general-purpose industrial machinery.

## Specifications

Model Numbers		CJT210-*****-***-30
Cylinder Bore mm		40, 50, 63, 80, 100, 125, 140, 160
Mounting Type		LA, FA, FB, CA, TC <sup>★3</sup>
Nominal Pressure <sup>★1</sup>		21 MPa
Maximum Allowable Pressure <sup>★1</sup>	Cap Side	24.5 MPa
	Rod Side	26.5 MPa
Proof Test Pressure <sup>★1</sup>		31.5 MPa
Minimum Working Pressure		Rod Side 0.45 MPa Cap Side 0.3 MPa
Operating Maximum Speed		Cylinder Bore 40 - 63 400 mm/s Cylinder Bore 80 - 125 300 mm/s Cylinder Bore 140, 160 200 mm/s
Operating Minimum Speed		8 mm/s
Maximum Stroke <sup>★2</sup> mm	Cylinder Bore 40	1600
	50 - 160	2000
Tolerance of Stroke		Refer to the table "Tolerance of Stroke" <sup>★4</sup>
Tolerance of Thread		JIS B 0211-6g (JIS grade 2 or equivalence)
Ambient Temperature Range		-10 - +80°C
Applicable Standard		Compliant with former JIS B8354

★1. Refer to page J-7 for definition of pressure terms.

★2. May be limited to even lower value in accordance with the buckling strength. Refer to page J-57 for strokes above buckling strength.

★3. Mounting Type SD(basic) is not available. If SD type is required, please select from "CJT 21MPa" series compact type (page J-41)

★4. Tolerance of Stroke

Stroke mm	Tolerance mm
100 or less	+0.8 0
More Than 100 to 250	+1.0 0
More Than 250 to 630	+1.25 0
More Than 630 to 1000	+1.4 0
More Than 1000 to 1600	+1.6 0
More Than 1600 to 2000	+1.8 0

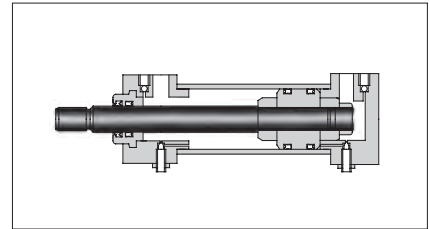
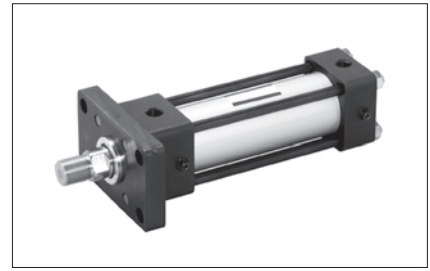

## Intermediate Trunnion (TC Type) Minimum Stroke Fabrication Range

Cylinder Bore mm	Minimum Stroke mm
63	15
80	31
100	39
125	34
140	32
160	54

По вопросам продаж и поддержки обращайтесь:

Алматы (7273)495-231  
Ангарск (3955)60-70-56  
Архангельск (8182)63-90-72  
Астрахань (8512)99-46-04  
Барнаул (3852)73-04-60  
Белгород (4722)40-23-64  
Благовещенск (4162)22-76-07  
Брянск (4832)59-03-52  
Владивосток (423)249-28-31  
Владикавказ (8672)28-90-48  
Владимир (4922)49-43-18  
Волгоград (844)278-03-48  
Вологда (8172)26-41-59  
Воронеж (473)204-51-73  
Екатеринбург (343)384-55-89

Иваново (4932)77-34-06  
Ижевск (3412)26-03-58  
Иркутск (395)279-98-46  
Казань (843)206-01-48  
Калининград (4012)72-03-81  
Калуга (4842)92-23-67  
Кемерово (3842)65-04-62  
Киров (8332)68-02-04  
Коломна (4966)23-41-49  
Кострома (4942)77-07-48  
Краснодар (861)203-40-90  
Красноярск (391)204-63-61  
Курган (3522)50-90-47  
Курск (4712)77-13-04  
Липецк (4742)52-20-81

Магнитогорск (3519)55-03-13  
Москва (495)268-04-70  
Мурманск (8152)59-64-93  
Набережные Челны (8552)20-53-41  
Нижний Новгород (831)429-08-12  
Новокузнецк (3843)20-46-81  
Новосибирск (383)227-86-73  
Ноябрьск (3496)41-32-12  
Омск (3812)21-46-40  
Орел (4862)44-53-42  
Оренбург (3532)37-68-04  
Пенза (8412)22-31-16  
Пермь (342)205-81-47  
Петрозаводск (8142)55-98-37  
Псков (8112)59-10-37

Ростов-на-Дону (863)308-18-15  
Рязань (4912)46-61-64  
Самара (846)206-03-16  
Санкт-Петербург (812)309-46-40  
Саранск (8342)22-96-24  
Саратов (845)249-38-78  
Севастополь (8692)22-31-93  
Симферополь (3652)67-13-56  
Смоленск (4812)29-41-54  
Сочи (862)225-72-31  
Ставрополь (8652)20-65-13  
Сургут (3462)77-98-35  
Сыктывкар (8212)25-95-17  
Тамбов (4752)50-40-97  
Тверь (4822)63-31-35

Тольятти (8482)63-91-07  
Томск (3822)98-41-53  
Тула (4872)33-79-87  
Тюмень (3452)66-21-18  
Улан-Удэ (3012)59-97-51  
Ульяновск (8422)24-23-59  
Уфа (347)229-48-12  
Хабаровск (4212)92-98-04  
Чебоксары (8352)28-53-07  
Челябинск (351)202-03-61  
Череповец (8202)49-02-64  
Чита (3022)38-34-83  
Якутск (4112)23-90-97  
Ярославль (4852)69-52-93

Россия +7(495)268-04-70

Казахстан +7(7172)727-132

Киргизия +996(312)96-26-47

yne@nt-rt.ru || <https://yuken.nt-rt.ru>

## Model Number Designation

F—	CJT210	—LA	50	B	100	B	—A	B	D	—F	—30
Packing Material	Series Number	Mounting Type	Cylinder Bore mm	Rod Size	Cylinder Stroke mm	Cushion Type	Port Position <sup>★2</sup>	Cushion Adj. Valve Position <sup>★2</sup>	Air Vent Valve Position <sup>★2</sup>	Options <sup>★1</sup>	Design Number
None : Nitrile Rubber Rubber (Standard)	CJT210 : 21MPa Series Standard Cylinder	LA, FA, FB, CA, TC	40, 50, 63, 80, 100, 125, 140, 160	B : Rod Size (Strong)	Cylinder Stroke	B : With Cushion on Both ends  R : With Cushion on the Rod side  H : With Cushion on the Cap side  N : Without Cushion	(Viewed from Rod End) A : Upper (Standard)  B : Right  C : Under  D : Left	B : Right (Standard)  A : Upper  C : Under  D : Left  N : No Cushion; adj. valve (Standard)	D : Left (Standard)  A : Upper  B : Right  C : Under	E : With Long Rod End Thread  F : With Dust Cover (Material: Nylon Tarpaulin, Heat resistant up to 80°C)  G : With Dust Cover (Material: Chloroprene , Heat resistant up to 130°C)  H : With Dust Cover (Material: Conex, Heat resistant up to 200°C)  K : With Lock Nut (E : Used in combination with long rod end thread)  L : With T-End <sup>★4</sup> (Rod End Eye)  M : With Y-End <sup>★4</sup> (Rod End Clevis)	30

★1. Using the options in combination is available.  
Please specify the option code in the alphabet.  
Ex.: EKL

★2. As for each direction of port, cushion adjustable valve and air vent valve, please select from (A)(B)(C)(D) viewed from rod end (see the figure on the below).  
However, the direction of port, cushion adjusting valve, and air vent valve are subject to the restrictions in the table below.

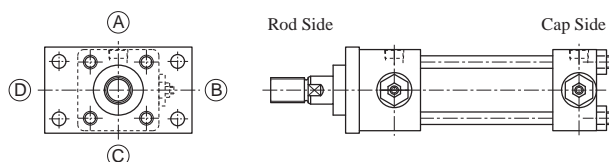

★3. Material of standard packings is Nitrile Rubber.  
F: Fluoro rubber, 6: Hydrogenated nitrile rubber are also available.

★4. Rod end attachment are fixed differently with and without lock nuts.

① With Lock Nut

Lock the rod end attachment with a lock nut since a set screw for fixing is not included.

② Without Lock Nut

Locked by set screw for fixing. Rod threads have pointings (drill holes). Please consult us separately for without pointing.

★5. Mounting Type SD is not available for CJT210. If SD type is required, please select from "CJT 21MPa" series compact type.

Port Position	Cushion Adjusting Valve Position	Air Vent Valve Position
A, B, C, D	Except port position	Except port position and cushion adjusting valve position

**Mounting Type**

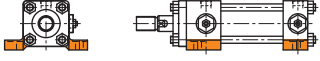
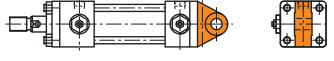
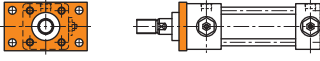
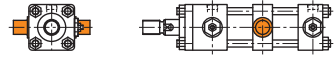
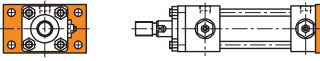
Code	Name	Illustration of Mounting Type	Code	Name	Illustration of Mounting Type
LA	Foot Mounting Side Lugs		CA	Cap Detachable Eye	
FA	Rod Rectangular Flange		TC	Intermediate Trunnion	
FB	Cap Rectangular Flange				

**Syllabus Table**

Rod Size Code	Cylinder Bore mm	Rod Size mm	Push/Pull	Pressurized Area cm <sup>2</sup>	Output kN				Velocity by a unit flow rate 10L/min mm/s	Flow rate by a unit velocity 10mm/s L/min
					1 MPa	7 MPa	14 MPa	21 MPa		
B	40	22	Push Pull	12.6 8.8	1.26 0.88	8.79 6.13	17.58 12.27	26.37 18.39	132 189	0.8 0.5
	50	28	Push Pull	19.6 13.5	1.96 1.35	13.74 9.43	27.48 18.86	41.20 28.28	85 123	1.2 0.8
	63	36	Push Pull	31.2 21.0	3.12 2.10	21.81 14.69	43.62 29.38	65.41 44.05	53 79	1.9 1.3
	80	45	Push Pull	50.3 34.3	5.03 3.43	35.17 24.04	70.34 48.08	105.50 72.11	33 49	3.0 2.1
	100	56	Push Pull	78.5 53.9	7.85 5.39	54.95 37.72	109.90 75.44	164.85 113.14	21 31	4.7 3.2
	125	70	Push Pull	122.7 84.2	12.27 8.42	85.86 58.93	171.72 117.87	257.46 176.79	14 20	7.4 5.1
	140	80	Push Pull	153.9 103.6	15.39 10.36	107.70 72.53	215.40 145.07	322.98 217.56	10.8 16	9.2 6.2
	160	90	Push Pull	201.0 137.4	20.10 13.74	140.67 96.16	281.34 192.33	421.89 288.33	8.3 12	12.1 8.2

**Mass Table**

Approx. Mass may be obtained from the formula below.

$$\text{Mass} = \text{A} + [\text{B} \times \text{Stroke}(\text{mm}) / 100] + \text{C} + \text{D}$$

Cylinder Bore mm	A Basic Mass	B Additional Mass By A Unit Stroke 100mm	C Basic Mass (Each Mounting)							D Additional Mass		
			LA	FA	FB	CA	CB	TA	TC	T-End (Rod End Eye) L	Y-End (Rod End Clevis) M	Lock Nut K
40	4.13	1.05	0.80	0.59	1.00	0.56	0.77	0.32	0.74	1.0	1.2	0.03
50	7.04	1.57	1.24	1.04	1.78	0.93	1.28	0.34	1.04	1.4	2.2	0.05
63	10.46	2.40	2.51	1.91	3.15	1.45	2.18	0.70	1.71	2.2	3.7	0.11
80	17.35	3.63	3.99	3.16	5.35	4.17	5.04	1.34	2.99	4.2	7.7	0.24
100	26.04	5.39	5.40	6.12	9.97	7.95	9.51	3.76	6.79	8.0	14.6	0.52
125	47.40	8.38	9.84	12.99	19.59	15.46	18.57	5.42	13.25	20.8	31.7	1.10
140	67.60	10.87	7.85	11.30	21.95	21.30	25.02	8.03	18.75	24.4	38.4	1.44
160	95.44	14.10	11.29	15.42	31.28	31.43	37.60	18.86	24.28	38.9	57.0	1.93

## Maximum stroke limited by buckling strength

### Calculation of Maximum Stroke

1. Calculate rod end coefficient  $n$  from the table on the right.
2. Calculate the maximum installation length  $L$  by applying various values such as cylinder bore, rod size, pressure, and rod end coefficient to the figure below.
3. Refer to the external dimensions and calculate the mounting length  $L_0$  when retracted.

Use the formula  $S=L-L_0$  and calculate the maximum stroke  $S$ .

(Example) Cylinder bore 100 mm, rod size 56 mm, mounting type TC (intermediate trunnion type) standard cylinder operated at 8 MPa pressure. Calculate the maximum stroke. The rod end attachment dimension when calculating the installation length  $L_0$  shall be 180 mm.

From the table on the right  $n=1$

From the figure below  $L \approx 1980$

From Dimensional Drawing (J-60) and Rod End Attachment (J-61)

$$L_0 = (181 + 180) + \frac{S}{2}$$

$$\text{therefore } S = L - L_0 = 1980 - \left[ (181 + 180) + \frac{S}{2} \right]$$

$$\text{hence } S \approx 1080 \text{ mm}$$

Mounting Type	Type	Rod End Coefficient $n$	Mounting Type	Type	Rod End Coefficient $n$
LA		1/4	FB		1/4
		2			2
		4			4
FA		1/4	TC		1
		2		CA	
		4			

$S=L-L_0$   
 $S$  : Stroke mm  
 $L$  : Mounting Length at extension mm  
 $L_0$  : Mounting Length at contraction mm  
 Note: For  $L_0$  dimensions, refer to dimensional drawing and add the dimensions of rod end attachment.

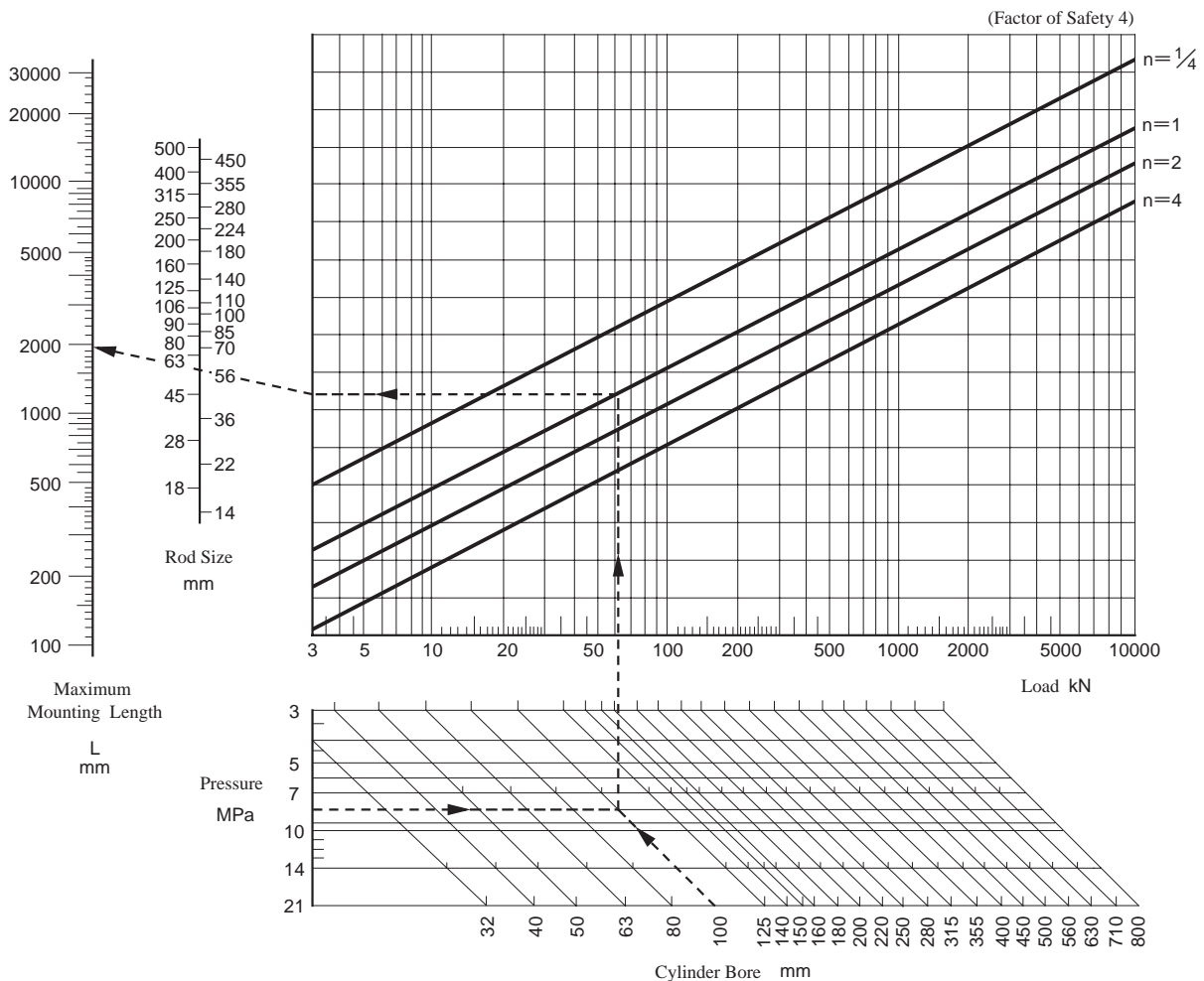

**LA : Foot Mounting Side Lugs**

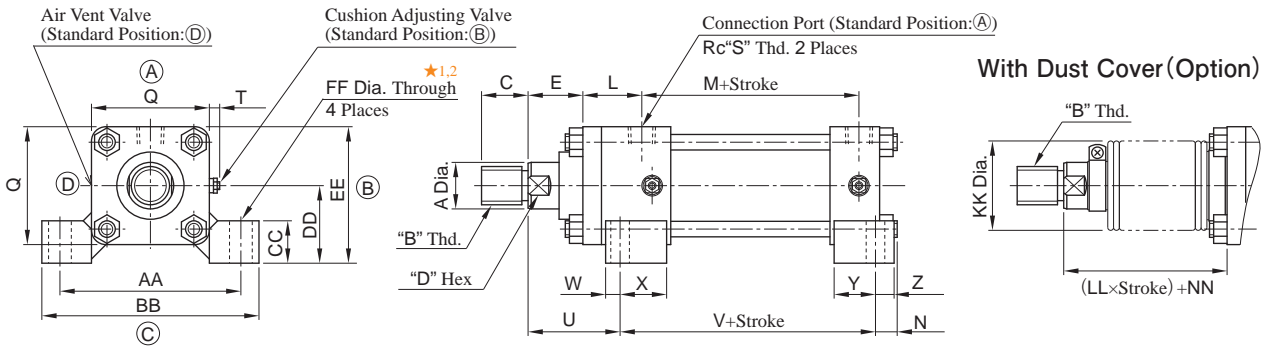

- ★1. The socket head cap screw shall be used as a mounting bolt.
- ★2. As for cylinder bore size 40-100, in case the port direction is ③ or ①, pipe fittings may interfere with cylinder mounting bolts. Refer to instructions on page J-4 for details.
- ★3. Long rod end thread type : the dimension "C" is the value marked in parentheses.

Cylinder Bore	A	B	C★3	D	E	L	M	N	Q	S	T	U	V	W	X	Y	Z	AA	BB	CC	DD	EE	FF	KK	LL		NN
																									Nylon Tarpaulin, Chloroprene	Conex	
40	22	M20×1.5	25 (45)	19	36	38	94	22	65	3/8	Max.13	59	111	12	38	25	11	98	122	19	42±0.15	74.5	11	50	1/3.5	1/2.5	53
50	28	M24×1.5	30 (50)	24	36	42	102	28	80	1/2	Max.13	63	120	14	36	30	15	118	145	24	55±0.15	95	14	63			56
63	36	M30×1.5	35 (60)	30	38	47	106	20	94	1/2	Max.13	71	132	18	41	39	18	140	175	35	63±0.15	110	18	71	1/4	1/3	64
80	45	M39×1.5	45 (80)	41	44	57	110	15	114	3/4	Max.13	80	152	18	49	49	18	175	210	41	75±0.25	132	22	80			64
100	56	M48×1.5	55 (95)	50	46	58	116	5	135	3/4	Max.13	89	162	23	43	59	23	215	260	40	85±0.25	152.5	26	100	1/5	1/3.5	66
125	70	M64×2	75 (125)	65	54	73	130	15	165	1	Max.13	106	182	28	54	64	28	270	330	47	105±0.25	187.5	33	125			78
140	80	M72×2	80 (140)	75	54	81	138	22	192	1	Max.13	114	187	28	54	61	28	280	335	45	112±0.25	208	33	125	1/4	1/4	74
160	90	M80×2	90 (155)	85	59	86	156	14	218	1	Max.13	127	212	31	56	76	31	315	375	50	125±0.25	234	36	140			74

**FA : Rod Rectangular Flange**

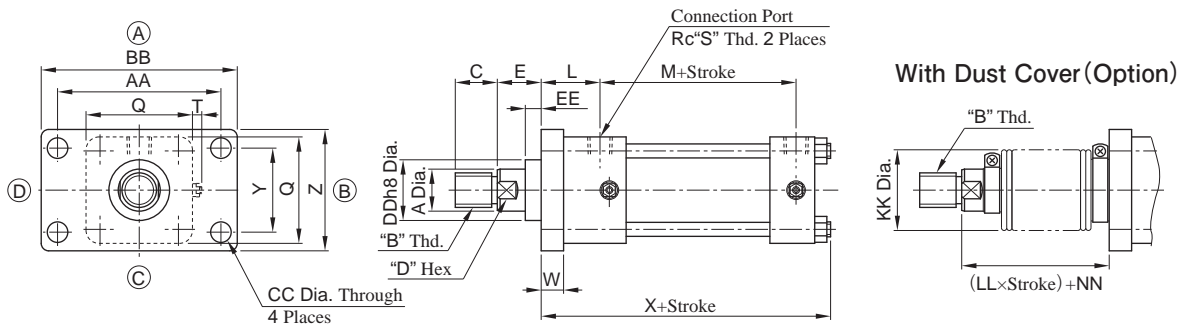

- ★ Long rod end thread type : the dimension "C" is the value marked in parentheses.

Cylinder Bore	A	B	C★	D	E	L	M	Q	S	T	W	X	Y	Z	AA	BB	CC	DD	EE	KK	LL		NN
																					Nylon Tarpaulin, Chloroprene	Conex	
40	22	M20×1.5	25 (45)	19	28	43	94	65	3/8	Max.13	16	161	50	73	98	122	11	40	11	50	1/3.5	1/2.5	45
50	28	M24×1.5	30 (50)	24	25	49	102	80	1/2	Max.13	20	182	60	88	118	145	14	46	9	63			45
63	36	M30×1.5	35 (60)	30	29	56	106	94	1/2	Max.13	24	194	73	106	140	175	18	55	6	71	1/4	1/3	55
80	45	M39×1.5	45 (80)	41	35	66	110	114	3/4	Max.13	27	212	90	130	175	210	22	65	9	80			55
100	56	M48×1.5	55 (95)	50	35	69	116	135	3/4	Max.13	31	221	115	165	215	260	26	80	6	100	1/5	1/3.5	55
125	70	M64×2	75 (125)	65	41	88	130	165	1	Max.13	39	264	145	205	270	330	33	95	4	125			65
140	80	M72×2	80 (140)	75	45	90	138	192	1	Max.13	41	278	160	218	280	335	33	105	6	125	1/4	1/4	65
160	90	M80×2	90 (155)	85	50	95	156	218	1	Max.13	46	303	180	243	315	375	36	120	6	140			65

**FB : Cap Rectangular Flange**

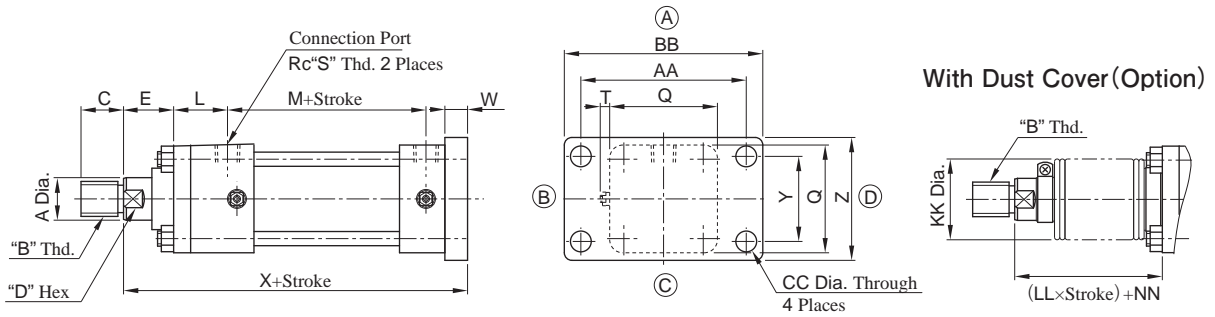

★ Long rod end thread type : the dimension "C" is the value marked in parentheses.

Cylinder Bore	A	B	C★	D	E	L	M	Q	S	T	W	X	Y	Z	AA	BB	CC	KK	LL		NN
																			Nylon Tarpaulin, Chloroprene	Conex	
40	22	M20×1.5	25 (45)	19	40	38	94	65	3/8	Max.13	16	201	50	73	98	122	11	50	1/3.5	1/2.5	57
50	28	M24×1.5	30 (50)	24	40	42	102	80	1/2	Max.13	20	222	60	88	118	145	14	63			60
63	36	M30×1.5	35 (60)	30	51	47	106	94	1/2	Max.13	24	246	73	106	140	175	18	71	1/4	1/3	77
80	45	M39×1.5	45 (80)	41	63	57	110	114	3/4	Max.13	27	277	90	130	175	210	22	80			83
100	56	M48×1.5	55 (95)	50	78	58	116	135	3/4	Max.13	31	301	115	165	215	260	26	100	1/5	1/3.5	98
125	70	M64×2	75 (125)	65	82	73	130	165	1	Max.13	39	349	145	205	270	330	33	125			106
140	80	M72×2	80 (140)	75	81	81	138	192	1	Max.13	41	366	160	218	280	335	33	125	1/4	1/1	101
160	90	M80×2	90 (155)	85	92	86	156	218	1	Max.13	46	405	180	243	315	375	36	140			107

**CA : Cap Detachable Eye**

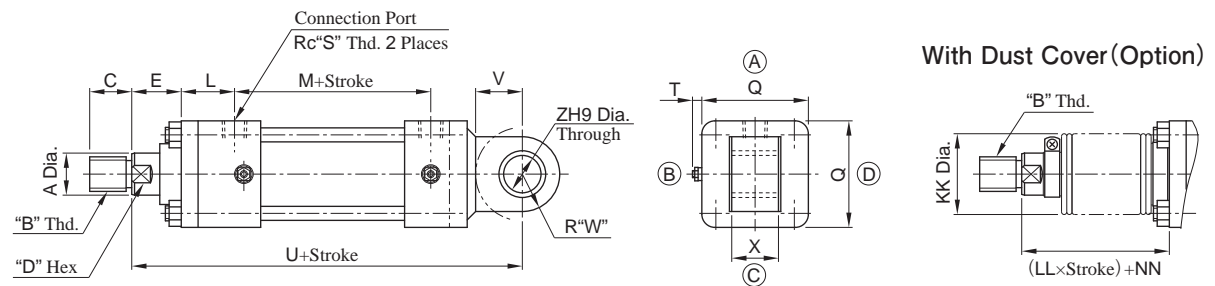

★ Long rod end thread type : the dimension "C" is the value marked in parentheses.

Cylinder Bore	A	B	C★	D	E	L	M	Q	S	T	U	V	W	X	Z	KK	LL		NN
																	Nylon Tarpaulin, Chloroprene	Conex	
40	22	M20×1.5	25 (45)	19	45	38	94	65	3/8	Max.13	221	25	25	32 <sup>-0.1</sup> <sub>-0.4</sub>	20	50	1/3.5	1/2.5	62
50	28	M24×1.5	30 (50)	24	47	42	102	80	1/2	Max.13	247	32	30	36 <sup>-0.1</sup> <sub>-0.4</sub>	25	63			67
63	36	M30×1.5	35 (60)	30	59	47	106	94	1/2	Max.13	277	40	35	40 <sup>-0.1</sup> <sub>-0.4</sub>	31.5	71	1/4	1/3	85
80	45	M39×1.5	45 (80)	41	58	57	110	114	3/4	Max.13	323	50	40	50 <sup>-0.1</sup> <sub>-0.4</sub>	40	80			78
100	56	M48×1.5	55 (95)	50	61	58	116	135	3/4	Max.13	350	63	50	63 <sup>-0.1</sup> <sub>-0.4</sub>	50	100	1/5	1/3.5	81
125	70	M64×2	75 (125)	65	67	73	130	165	1	Max.13	417	79	63	80 <sup>-0.1</sup> <sub>-0.6</sub>	63	125			91
140	80	M72×2	80 (140)	75	57	81	138	192	1	Max.13	440	89	71	80 <sup>-0.1</sup> <sub>-0.6</sub>	71	125	1/4	1/1	77
160	90	M80×2	90 (155)	85	66	86	156	218	1	Max.13	484	100	80	100 <sup>-0.1</sup> <sub>-0.6</sub>	80	140			81

**TC : Intermediate Trunnion**

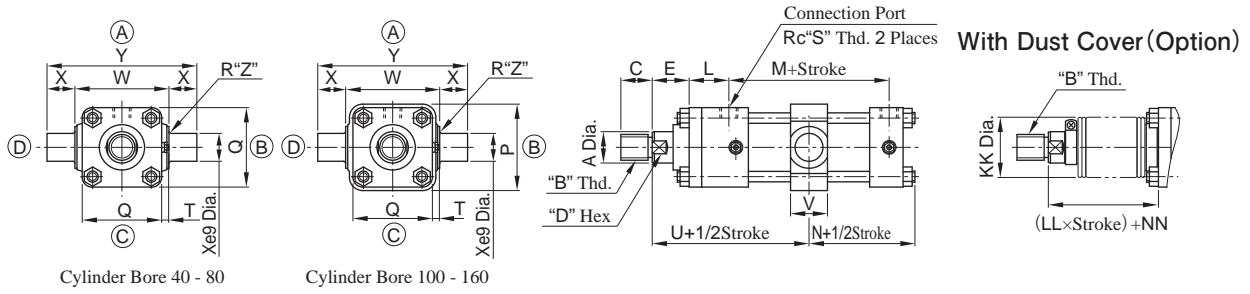

★ Long rod end thread type : the dimension "C" is the value marked in parentheses.

Cylinder Bore	A	B	C★	D	E	L	M	N	P	Q	S	T	U	V	W	X	Y	Z	KK	LL		NN
																				Nylon Tarpaulin, Chloroprene	Conex	
40	22	M20×1.5	25 (45)	19	30	38	94	64	—	65	3/8	Max.13	122	33	73 <sup>0</sup> <sub>-0.3</sub>	25	123	2.5	50	1/3.5	1/2.5	47
50	28	M24×1.5	30 (50)	24	33	42	102	77	—	80	1/2	Max.13	131	33	88 <sup>0</sup> <sub>-0.35</sub>	25	138	2.5	63			53
63	36	M30×1.5	35 (60)	30	36	47	106	73	—	94	1/2	Max.13	148	43	106 <sup>0</sup> <sub>-0.35</sub>	31.5	169	2.5	71	1/4	1/3	62
80	45	M39×1.5	45 (80)	41	41	57	110	75	—	114	3/4	Max.13	169	53	128 <sup>0</sup> <sub>-0.4</sub>	40	208	3	80			61
100	56	M48×1.5	55 (95)	50	47	58	116	76	146	135	3/4	Max.13	181	63	170 <sup>0</sup> <sub>-0.4</sub>	50	270	3	100	1/5	1/3.5	67
125	70	M64×2	75 (125)	65	60	73	130	101	185	165	1	Max.13	208	78	205 <sup>0</sup> <sub>-0.46</sub>	63	331	4	125			84
140	80	M72×2	80 (140)	75	60	81	138	111	210	192	1	Max.13	218	88	225 <sup>0</sup> <sub>-0.46</sub>	71	367	4	125	1/4	1/4	80
160	90	M80×2	90 (155)	85	60	86	156	112	230	218	1	Max.13	242	98	255 <sup>0</sup> <sub>-0.52</sub>	80	415	4	140			75

## Options

### Lock Nut : Option Code "K"

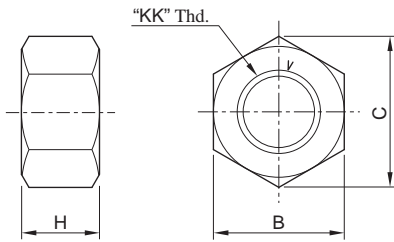

KK	H	B	C
M20×1.5	12	27	31.2
M24×1.5	14	32	37.0
M30×1.5	17	41	47.3
M39×1.5	20	55	63.5
M48×1.5	26	70	80.8
M64×2	35	90	104
M72×2	38	100	115
M80×2	43	110	127

### Rod End Attachment

#### T-End (Rod End Eye) : Option Code "L"

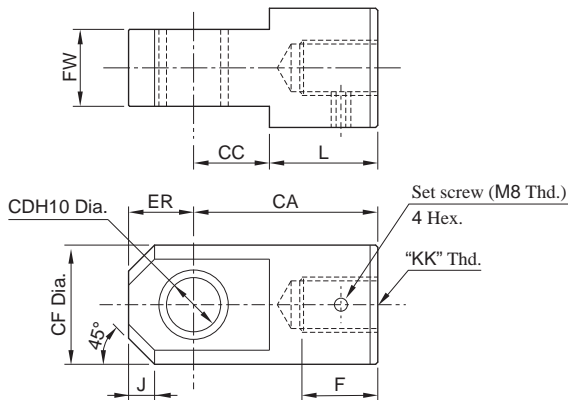

Cylinder Bore	KK	F	CA	CC	CD	CF	ER	FW	J	L
40	M20×1.5	32	70	28	20	49	25	31.5 <sup>-0.1</sup> <sub>-0.4</sub>	10	42
50	M24×1.5	35	85	35	25	55	30	35.5 <sup>-0.1</sup> <sub>-0.4</sub>	12	50
63	M30×1.5	47	115	43	31.5	62	35	40 <sup>-0.1</sup> <sub>-0.4</sub>	15	72
80	M39×1.5	62	145	55	40	79	40	50 <sup>-0.1</sup> <sub>-0.4</sub>	20	90
100	M48×1.5	77	180	65	50	100	50	63 <sup>-0.1</sup> <sub>-0.4</sub>	30	115
125	M64×2	82	225	85	63	130	65	80 <sup>-0.1</sup> <sub>-0.6</sub>	40	140
140	M72×2	97	240	90	71	140	70	80 <sup>-0.1</sup> <sub>-0.6</sub>	45	150
160	M80×2	112	280	100	80	160	80	100 <sup>-0.1</sup> <sub>-0.6</sub>	50	180

#### Y-End (Rod End Clevis) : Option Code "M"

Cylinder Bore 40, 63, 80

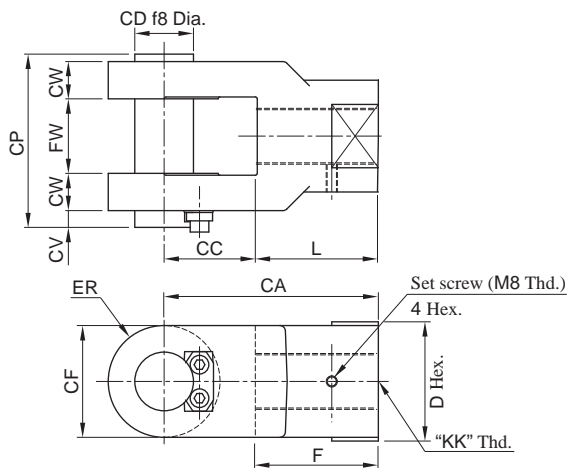

Cylinder Bore 50, 100 - 160

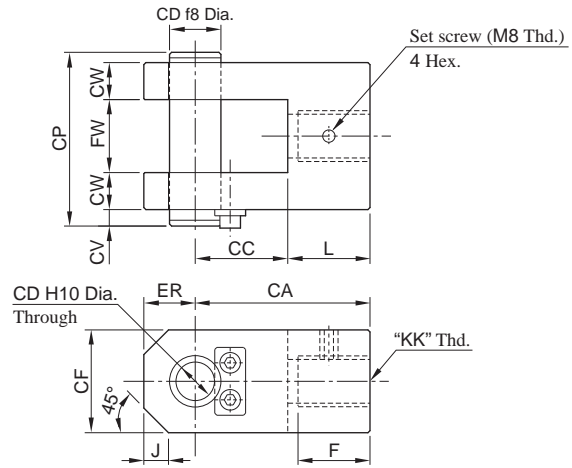

Cylinder Bore	KK	F	CA	CC	CD	CF	ER	FW	CW	CV	CP	D	J	L
40	M20×1.5	38	70	32	20	40	R20	31.5 <sup>+0.4</sup> <sub>+0.1</sub>	16	8	76.5	41	-	38
50	M24×1.5	35	85	45	25	50	25	35.5 <sup>+0.4</sup> <sub>+0.1</sub>	18	8	84.5	-	12	40
63	M30×1.5	65	115	50	31.5	60	R30	40 <sup>+0.4</sup> <sub>+0.1</sub>	20	8	93	60	-	65
80	M39×1.5	85	145	60	40	80	R40	50 <sup>+0.4</sup> <sub>+0.1</sub>	25	12	117	80	-	85
100	M48×1.5	77	180	70	50	100	50	63 <sup>+0.4</sup> <sub>+0.1</sub>	31.5	12	143	-	30	110
125	M64×2	82	225	90	63	120	65	80 <sup>+0.6</sup> <sub>+0.1</sub>	40	18	183	-	30	135
140	M72×2	97	240	100	71	140	70	80 <sup>+0.6</sup> <sub>+0.1</sub>	40	18	183	-	40	140
160	M80×2	112	280	110	80	160	80	100 <sup>+0.6</sup> <sub>+0.1</sub>	40	24	210	-	40	170



## List of Seals

### CJT 210

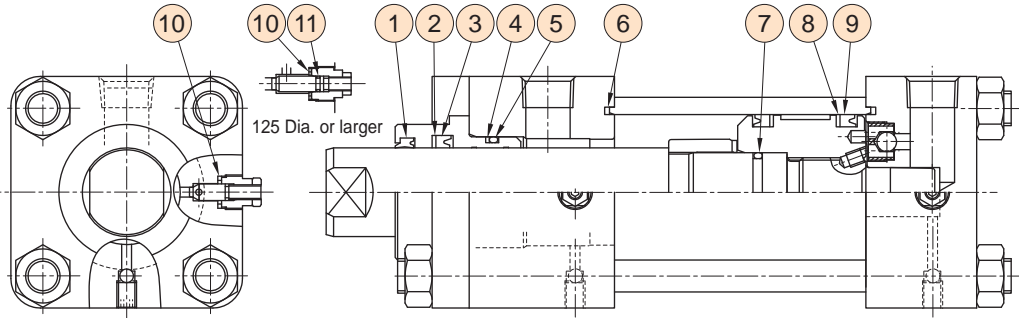

Cylinder Bore	Model Numbers <sup>★1</sup> for Seal Kit	Dust Seal <sup>①</sup>	Backup Ring for Rod Packing <sup>②</sup>	Rod Packing <sup>③</sup>	Backup Ring for Bush <sup>④</sup>	O-Ring for Bush <sup>★2</sup> <sup>⑤</sup>
40	KS-CJT210-40B-30	LBH-22	22×30×1	IUH-22A	BUR-G25	G25
50	KS-CJT210-50B-30	LBH-28	28×35.5×1	IUH-28	BUR-G31 <sup>★3</sup>	G30
63	KS-CJT210-63B-30	LBH-36	36×46×1.5	IUH-36	BUR-G40	G40
80	KS-CJT210-80B-30	LBH-45	45×56×1.5	IUH-45A	BUR-G55	G55
100	KS-CJT210-100B-30	LBH-56	56×66×1.5	IUH-56	BUR-G65	G65
125	KS-CJT210-125B-30	LBH-70	70×80×1.5	IUH-70	BUR-G80	G80
140	KS-CJT210-140B-30	LBH-80	80×90×1.5	IUH-80	BUR-G90	G90
160	KS-CJT210-160B-30	LBH-90	90×105×2	IUH-90	BUR-G100	G100

Cylinder Bore	Model Numbers <sup>★1</sup> for Seal Kit	Cover Seal <sup>⑥</sup>	O-Ring for Piston <sup>★2</sup> <sup>⑦</sup>	Backup Ring for Piston Packing <sup>⑧</sup>	Piston Packing <sup>⑨</sup>	Cushion Valve Seal <sup>⑩</sup>	O-Ring for Cushion <sup>★2</sup> <sup>⑪</sup>	Item	Qty
40	KS-CJT210-40B-30	TT-40	P16	40×30×1.5	OUHR-40	CX-12H	—	①	1
50	KS-CJT210-50B-30	TT-50	P21	50×40×1.5	OUHR-50	CX-12H	—	②	1
63	KS-CJT210-63B-30	TT-63	G25	63×53×1.5	OUHR-63	CX-12H	—	③	1
80	KS-CJT210-80B-30	TT-80	G35	80×71×2	OUHR-80A	CX-14H	—	④	1
100	KS-CJT210-100B-30	TT-100	G45	100×85×3	OUHR-100	CX-14H	—	⑤	1
125	KS-CJT210-125B-30	TT-125	G55	125×112×3	OUHR-125	CR-18H	S7	⑥	2
140	KS-CJT210-140B-30	TT-140	G65	140×125×3	OUHR-140	CR-18H	S7	⑦	1
160	KS-CJT210-160B-30	TT-160	G75	160×145×3	OUHR-160	CR-18H	S7	⑧	2
								⑨	2
								⑩	2
								⑪	2

★1. Please specify the seal kit numbers above when ordering the seals.

★2. O-rings are the following standards.

Model Numbers	Standard
⑤ O-Ring for Bush	OR NBR-70-1 P(G)**-N
⑦ O-Ring for Piston	OR NBR-90 P(G)**-N
⑪ O-Ring for Cushion	Special Standard

★3. Backup rings are made to our standard

★4. Material of standard packings is Nitrile Rubber. For Fluorocarbon Rubber and Hydrogenated Nitrile Rubber materials, specify the following code after "KS-".

Fluoro rubber: F-, Hydrogenated nitrile rubber: 6-

Note : The packing code changes without notice.

## Tie Rod Tightening

When tightening tie rod, do not tighten only one tie rod tightly at a time, but gradually tighten the tie rods in the order of the numbers shown in the figure on the right. Note that one-sided tightening of tie rods may cause operation failure or chattering.

### Mounting Type (SD·LA·FA·FB·CA)

Bore mm	40	50	63	80	100	125	140	160
Tightening Torque Nm	41	70	120	170	280	500	880	1100

### Mounting Type (TC)

Bore mm	Rod Size	40	50	63	80	100	125	140	160
Tightening Torque Nm	A	41	70	120	200	330	600	1050	1300
	B	41	70	120	170	280	500	880	1100

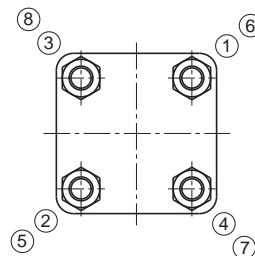

## Installation between Current and New Design

"CJT 21 MPa" Series Hydraulic Cylinders undergone the following model changes.

### Major Changes

① Overall length shortened

② Structural Change

- The cushion structure has been changed for more stable cushioning performance.
- The conventional structure with a check valve on the outer surface of the cover has been eliminated, and a cushion ring that doubles as a check valve has been adopted on the rod side.  
A check valve directly connected to the bottom hole of the port is used on the cap side.
- An air vent valve is installed separately from the check valve to prevent the check valve from being exposed to the outside surface.
- All cushion adjusting valves have been commonized.
- Basically, internal parts of current and new products are not interchangeable.

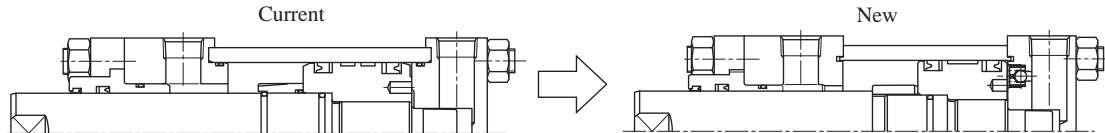

### Design Number

Series Number	Change Design
CJT210	20 Design to 30 Design

### Mounting Type

Mounting type "SD" has been eliminated in the 30 design.

If mounting type "SD" is required, please select from "CJT 21MPa" series compact type.

### Interchangeability in Installation

The distance between ports and the total length have been changed, but there is no change in the basic installation.

Series Number	Change of port-to-port distance.
CJT210	Pages J-65 to J-67, dimension M.

★Please consult us separately for dimensions in "CA" and "TC" Series.

### Air Vent Valve

The shape has been changed and unified.

Current	New
<p>Cylinder Bore 40 - 80</p> <p>Valve Seal</p> <p>Tightening Torque : 8 - 10 Nm</p>	<p>Hex. Socket Set Screw</p> <p>Rigid Ball</p> <p>Tightening Torque : 3 - 5 Nm</p>
<p>Cylinder Bore 100 - 160</p> <p>Valve Seal</p> <p>Tightening Torque : 8 - 10 Nm</p>	

### Cushion Adjusting Valve

Current	New
<p>Cushion Adjusting Screw</p> <p>Cushion Plug</p> <p>Tightening Torque : 12 - 15 Nm</p> <p>Cushion Adjusting Valve Seal</p>	<p>Lock Nut</p> <p>Cushion Plug</p> <p>Cushion Adjusting Screw</p> <p>Cushion Adjusting Valve Seal</p> <p>Tightening Torque : 7 - 8 Nm</p>
<p>Prescribed lift: from fully closed to 3 turns.</p>	<p>Prescribed lift: from fully closed to end of stroke.</p>

●Cushion

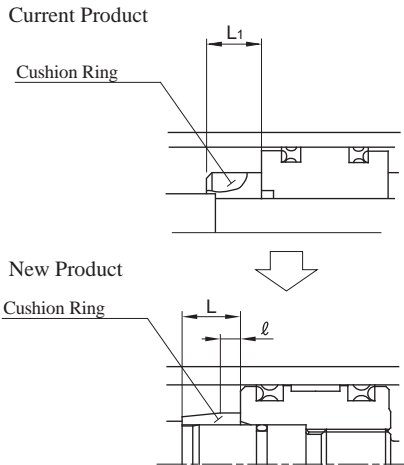

Cushion Length

Cylinder Bore mm	Current	New	
	Cushion Ring Length L1 mm	Cushion Ring Length L mm	Cushion Ring Parallel Part Length ℓ mm
40	20	26	10
50	20	28	10
63	20	28	10
80	25	30	12
100	25	30	12
125	25	33	15
140	25	33	15
160	25	33	15

Note : The cushioning effect will weaken if the cushion ring is not used at the end of the stroke and is stopped more than 5mm before the end of the stroke.

●Specifications

The new and current are identical except for the following.

Cylinder Bore mm	Maximum Stroke	
	Current mm	New mm
40	1500	1600

●Model Number Designation

The notes have been changed along with the design numbers. Refer to page J-55 for the changed notes.

●Mass Table

Mass has been changed in general. Refer to page J-56 for changed mass.

●List of Seals

Seals have been added, changed and deleted. Refer to page J-62 for changes.

●Foot Mounting Side Lugs (LA Type) Piping Precautions

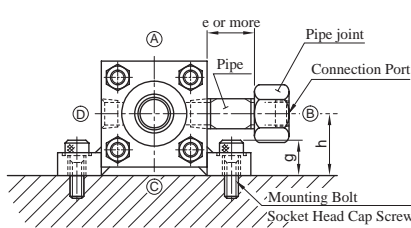

Cylinder Bore	e		g		h	
	Current	New	Current	New	Current	New
40	26	28.5	25	29	42	47
50	30	32.5	32	36	55	61
63	38	41	41	51	63	69
80	43	48.5	50	61	75	85
100	50	62.5	59	74	85	95

●Tie Rod Tightening

Current									New																	
Bore mm	40	50	63	80	100	125	140	160	Mounting Type (SD · LA · FA · FB · CA)																	
	Tightening Torque Nm	70	120	170	250	460	880	1100	1400	Bore mm	40	50	63	80	100	125	140	160	Tightening Torque Nm	41	70	120	170	280	500	880
									Mounting Type (TC)																	
Bore mm	Rod Size		40	50	63	80	100	125	140	160																
Tightening Torque Nm	A		41	70	120	200	330	600	1050	1300																
	B		41	70	120	170	280	500	880	1100																

## ● Dimensions

The new and current are identical except for the following dimension.

### CJT210-LA

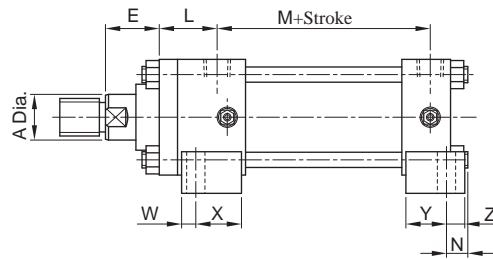
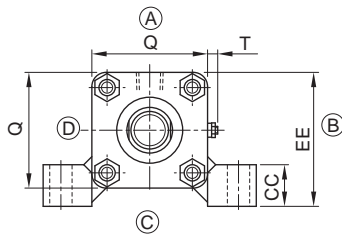

With Dust Cover (Option)

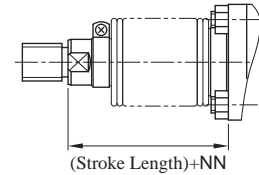

Cylinder Bore	Current														New													
	A	E	L	M	N	Q	T	W	X	Y	Z	CC	EE	NN	A	E	L	M	N	Q	T	W	X	Y	Z	CC	EE	NN
40	22.4	30	43	98	29	70	Max.6	16	31	16	16	15	77	47	22	36	38	94	22	65	Max.13	12	38	25	11	19	74.5	53
50	28	30	48	106	33	85	Max.6	18	34	18	19	20	97.5	50	28	36	42	102	28	80	Max.13	14	36	30	15	24	95	56
63	35.5	35	56	113	35	100	Max.6	18	39	18	19	25	113	61	36	38	47	106	20	94	Max.13	18	41	39	18	35	110	64
80	45	35	69	129	39	125	Max.6	21	46	21	21	30	137.5	55	45	44	57	110	15	114	Max.13	18	49	49	18	41	132	64
100	56	40	71	139	40	160	Max.6	23	44	23	24	35	165	60	56	46	58	116	5	135	Max.13	23	43	59	23	40	152.5	66
125	71	45	83	159	49	190	Max.6	28	49	28	29	45	200	69	70	54	73	130	15	165	Max.13	28	54	64	28	47	187.5	78
140	80	50	86	164	51	215	Max.6	28	49	28	29	45	219.5	70	80	54	81	138	22	192	Max.13	28	54	61	28	45	208	74
160	90	55	94	186	49	240	Max.6	31	49	31	31	50	245	70	90	59	86	156	14	218	Max.13	31	56	76	31	50	234	74

### CJT210-FA

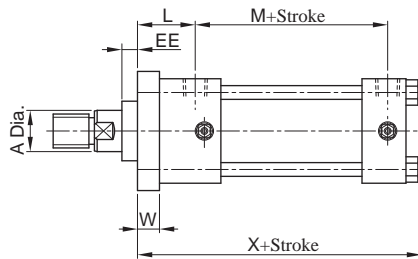
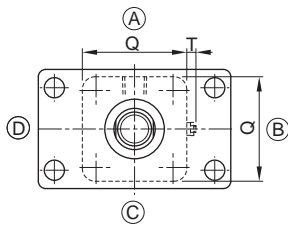

Cylinder Bore	Current								New							
	A	L	M	Q	T	W	X	EE	A	L	M	Q	T	W	X	EE
40	22.4	45	98	70	Max.6	15	171	9	22	43	94	65	Max.13	16	161	11
50	28	53	106	85	Max.6	20	191	9	28	49	102	80	Max.13	20	182	9
63	35.5	62	113	100	Max.6	24	209	9	36	56	106	94	Max.13	24	194	6
80	45	69	129	125	Max.6	24	236	9	45	66	110	114	Max.13	27	212	9
100	56	76	139	160	Max.6	31	256	9	56	69	116	135	Max.13	31	221	6
125	71	87	159	190	Max.6	37	296	9	70	88	130	165	Max.13	39	264	4
140	80	91	164	215	Max.6	41	307	9	80	90	138	192	Max.13	41	278	6
160	90	99	186	240	Max.6	46	338	9	90	95	156	218	Max.13	46	303	6

**CJT210-FB**

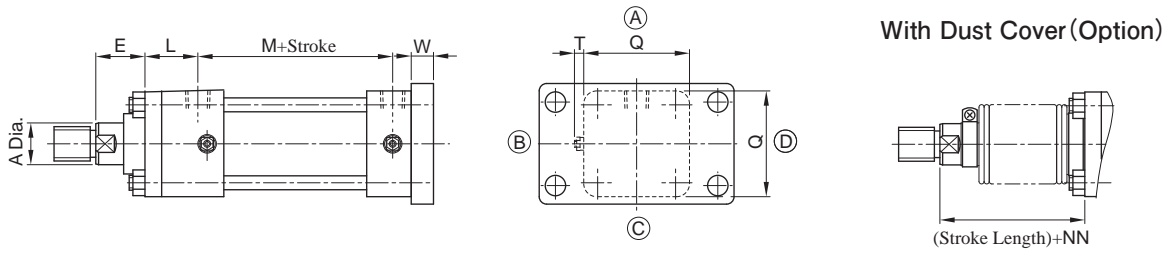

Cylinder Bore	Current								New							
	A	E	L	M	Q	T	W	NN	A	E	L	M	Q	T	W	NN
40	22.4	30	43	98	70	Max. 6	15	47	22	40	38	94	65	Max. 13	16	57
50	28	30	48	106	85	Max. 6	20	50	28	40	42	102	80	Max. 13	20	60
63	35.5	35	56	113	100	Max. 6	24	61	36	51	47	106	94	Max. 13	24	77
80	45	35	69	129	125	Max. 6	24	55	45	63	57	110	114	Max. 13	27	83
100	56	40	71	139	160	Max. 6	31	60	56	78	58	116	135	Max. 13	31	98
125	71	45	83	159	190	Max. 6	37	69	70	82	73	130	165	Max. 13	39	106
140	80	50	86	164	215	Max. 6	41	70	80	81	81	138	192	Max. 13	41	101
160	90	55	94	186	240	Max. 6	46	70	90	92	86	156	218	Max. 13	46	107

**CJT210-CA**

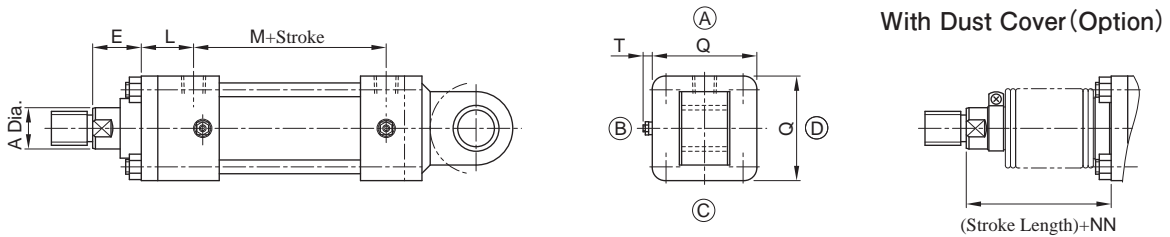

Cylinder Bore	Current								New							
	A	E	L	M	Q	T	NN	A	E	L	M	Q	T	NN		
40	22.4	30	43	98	70	Max. 6	47	22	45	38	94	65	Max. 13	62		
50	28	30	48	106	85	Max. 6	50	28	47	42	102	80	Max. 13	67		
63	35.5	35	56	113	100	Max. 6	61	36	59	47	106	94	Max. 13	85		
80	45	35	69	129	125	Max. 6	55	45	58	57	110	114	Max. 13	78		
100	56	40	71	139	160	Max. 6	60	56	61	58	116	135	Max. 13	81		
125	71	45	83	159	190	Max. 6	69	70	67	73	130	165	Max. 13	91		
140	80	50	86	164	215	Max. 6	70	80	57	81	138	192	Max. 13	77		
160	90	55	94	186	240	Max. 6	70	90	66	86	156	218	Max. 13	81		

## CJT210-TC

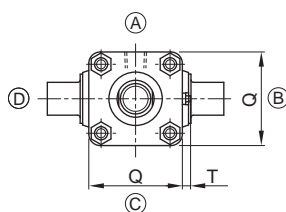

Cylinder Bore 40 - 80

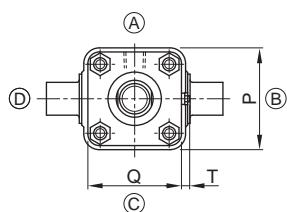

Cylinder Bore 100 - 160

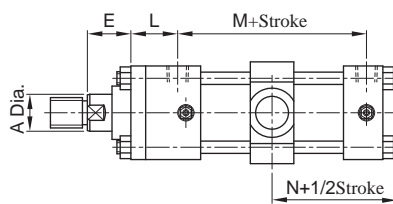

With Dust Cover  
(Option)

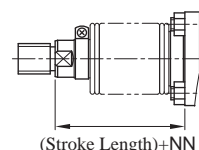

Cylinder Bore	Current										New								
	A	E	L	M	N	P	Q	T	NN	A	E	L	M	N	P	Q	T	NN	
40	22.4	30	43	98	77	—	70	Max. 6	47	22	30	38	94	64	—	65	Max. 13	47	
50	28	30	48	106	85	—	85	Max. 6	50	28	33	42	102	77	—	80	Max. 13	53	
63	35.5	35	56	113	90	—	100	Max. 6	61	36	36	47	106	73	—	94	Max. 13	62	
80	45	35	69	129	102	—	125	Max. 6	55	45	41	57	110	75	—	114	Max. 13	61	
100	56	40	71	139	110	—	160	Max. 6	60	56	47	58	116	76	146	135	Max. 13	67	
125	71	45	83	159	129	—	190	Max. 6	69	70	60	73	130	101	185	165	Max. 13	84	
140	80	50	86	164	134	—	215	Max. 6	70	80	60	81	138	111	210	192	Max. 13	80	
160	90	55	94	186	146	—	240	Max. 6	70	90	60	86	156	112	230	218	Max. 13	75	

По вопросам продаж и поддержки обращайтесь:

Алматы (7273)495-231  
 Ангарск (3955)60-70-56  
 Архангельск (8182)63-90-72  
 Астрахань (8512)99-46-04  
 Барнаул (3852)73-04-60  
 Белгород (4722)40-23-64  
 Благовещенск (4162)22-76-07  
 Брянск (4832)59-03-52  
 Владивосток (423)249-28-31  
 Владикавказ (8672)28-90-48  
 Владимир (4922)49-43-18  
 Волгоград (844)278-03-48  
 Вологда (8172)26-41-59  
 Воронеж (473)204-51-73  
 Екатеринбург (343)384-55-89  
 Иваново (4932)77-34-06  
 Ижевск (3412)26-03-58  
 Иркутск (395)279-98-46  
 Казань (843)206-01-48

Калининград (4012)72-03-81  
 Калуга (4842)92-23-67  
 Кемерово (3842)65-04-62  
 Киров (8332)68-02-04  
 Коломна (4966)23-41-49  
 Кострома (4942)77-07-48  
 Краснодар (861)203-40-90  
 Красноярск (391)204-63-61  
 Курган (3522)50-90-47  
 Курск (4712)77-13-04  
 Липецк (4742)52-20-81  
 Магнитогорск (3519)55-03-13  
 Москва (495)268-04-70  
 Мурманск (8152)59-64-93  
 Набережные Челны (8552)20-53-41  
 Нижний Новгород (831)429-08-12  
 Новокузнецк (3843)20-46-81  
 Новосибирск (383)227-86-73  
 Ноябрьск (3496)41-32-12

Омск (3812)21-46-40  
 Орел (4862)44-53-42  
 Оренбург (3532)37-68-04  
 Пенза (8412)22-31-16  
 Пермь (342)205-81-47  
 Петрозаводск (8142)55-98-37  
 Псков (8112)59-10-37  
 Ростов-на-Дону (863)308-18-15  
 Рязань (4912)46-61-64  
 Самара (846)206-03-16  
 Санкт-Петербург (812)309-46-40  
 Саранск (8342)22-96-24  
 Саратов (845)249-38-78  
 Севастополь (8692)22-31-93  
 Симферополь (3652)67-13-56  
 Смоленск (4812)29-41-54  
 Сочи (862)225-72-31  
 Ставрополь (8652)20-65-13  
 Сургут (3462)77-98-35

Сыктывкар (8212)25-95-17  
 Тамбов (4752)50-40-97  
 Тверь (4822)63-31-35  
 Тольятти (8482)63-91-07  
 Томск (3822)98-41-53  
 Тула (4872)33-79-87  
 Тюмень (3452)66-21-18  
 Улан-Удэ (3012)59-97-51  
 Ульяновск (8422)24-23-59  
 Уфа (347)229-48-12  
 Хабаровск (4212)92-98-04  
 Чебоксары (8352)28-53-07  
 Челябинск (351)202-03-61  
 Череповец (8202)49-02-64  
 Чита (3022)38-34-83  
 Якутск (4112)23-90-97  
 Ярославль (4852)69-52-93

Россия +7(495)268-04-70

Казахстан +7(7172)727-132

Киргизия +996(312)96-26-47