

"CJT 21 MPa" Series Compact Type Hydraulic Cylinders

YUKEN's "CJT 21 MPa" Series Compact Type Hydraulic Cylinders are higher nominal pressure for use in a wide range of general-purpose industrial machinery.

Compared to the conventional "CJT 21 MPa" Series Hydraulic Cylinders, the smaller outer dimensions allow for more compact equipment.

Moreover, Switch-Set "CJT" Series Hydraulic Cylinders with a proximity switch which facilitates detecting a position with a slide proximity switch on the cylinder body is also available.

(Refer to page J-69 for details)

Specifications

Model Numbers		CJT210C-*****-***-20
Cylinder Bore	mm	40, 50, 63, 80, 100, 125, 140, 160
Mounting Type		SD, LA, FA, FB, CA, TC
Nominal Pressure ^{★1}		21 MPa
Maximum Allowable Pressure ^{★1}	Cap Side Rod A,B	26.5 MPa
	Rod Side Rod A	26.5 MPa
	Rod Side Rod B	24.5 MPa
Proof Test Pressure ^{★1}		31.5 MPa
Minimum Working Pressure	Rod Side Rod A	0.6 MPa or less
	Rod Side Rod B	0.45 MPa or less
	Cap Side Rod A,B	0.3 MPa or less
Operating Maximum Speed		Cylinder Bore 40 - 63 400 mm/s Cylinder Bore 80 - 125 300 mm/s Cylinder Bore 140, 160 200 mm/s
Operating Minimum Speed		8 mm/s
Maximum Stroke ^{★2} mm	Cylinder Bore 40	1600
	Cylinder Bore 50 - 160	2000
Tolerance of Stroke		Refer to the table "Tolerance of Stroke" ^{★3}
Tolerance of Thread		JIS B 0211-6g (JIS grade 2 or equivalence)
Ambient Temperature Range		-10 - +80°C
Applicable Standard		Compliant with former JIS B8354

★1. Refer to page J-7 for definition of pressure terms.

★2. May be limited to even lower value in accordance with the buckling strength. Refer to page J-44 for strokes above buckling strength.

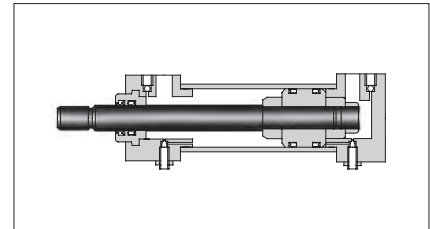
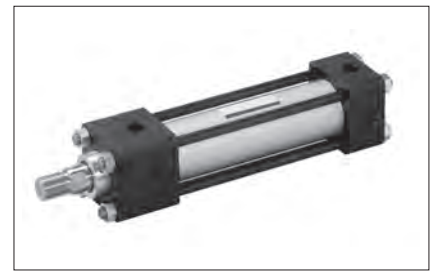

Graphic Symbol



Intermediate Trunnion (TC Type) Minimum Stroke Fabrication Range

Cylinder Bore mm	Minimum Stroke mm	
	Rod A	Rod B
80	28	14
100	33	21
125	48	34
140	52	38
160	55	41

★3. Tolerance of Stroke

Stroke mm	Tolerance mm
100 or less	+0.8 0
More Than 100 to 250	+1.0 0
More Than 250 to 630	+1.25 0
More Than 630 to 1000	+1.4 0
More Than 1000 to 1600	+1.6 0
More Than 1600 to 2000	+1.8 0

По вопросам продаж и поддержки обращайтесь:

Алматы (7273)495-231
Ангарск (3955)60-70-56
Архангельск (8182)63-90-72
Астрахань (8512)99-46-04
Барнаул (3852)73-04-60
Белгород (4722)40-23-64
Благовещенск (4162)22-76-07
Брянск (4832)59-03-52
Владивосток (423)249-28-31
Владикавказ (8672)28-90-48
Владимир (4922)49-43-18
Волгоград (844)278-03-48
Вологда (8172)26-41-59
Воронеж (473)204-51-73
Екатеринбург (343)384-55-89

Иваново (4932)77-34-06
Ижевск (3412)26-03-58
Иркутск (395)279-98-46
Казань (843)206-01-48
Калининград (4012)72-03-81
Калуга (4842)92-23-67
Кемерово (3842)65-04-62
Киров (8332)68-02-04
Коломна (4966)23-41-49
Кострома (4942)77-07-48
Краснодар (861)203-40-90
Красноярск (391)204-63-61
Курган (3522)50-90-47
Курск (4712)77-13-04
Липецк (4742)52-20-81

Магнитогорск (3519)55-03-13
Москва (495)268-04-70
Мурманск (8152)59-64-93
Набережные Челны (8552)20-53-41
Нижний Новгород (831)429-08-12
Новокузнецк (3843)20-46-81
Новосибирск (383)227-86-73
Ноябрьск (3496)41-32-12
Омск (3812)21-46-40
Орел (4862)44-53-42
Оренбург (3532)37-68-04
Пенза (8412)22-31-16
Пермь (342)205-81-47
Петрозаводск (8142)55-98-37
Псков (8112)59-10-37

Ростов-на-Дону (863)308-18-15
Рязань (4912)46-61-64
Самара (846)206-03-16
Санкт-Петербург (812)309-46-40
Саранск (8342)22-96-24
Саратов (845)249-38-78
Севастополь (8692)22-31-93
Симферополь (3652)67-13-56
Смоленск (4812)29-41-54
Сочи (862)225-72-31
Ставрополь (8652)20-65-13
Сургут (3462)77-98-35
Сыктывкар (8212)25-95-17
Тамбов (4752)50-40-97
Тверь (4822)63-31-35

Тольятти (8482)63-91-07
Томск (3822)98-41-53
Тула (4872)33-79-87
Тюмень (3452)66-21-18
Улан-Удэ (3012)59-97-51
Ульяновск (8422)24-23-59
Уфа (347)229-48-12
Хабаровск (4212)92-98-04
Чебоксары (8352)28-53-07
Челябинск (351)202-03-61
Череповец (8202)49-02-64
Чита (3022)38-34-83
Якутск (4112)23-90-97
Ярославль (4852)69-52-93

Россия +7(495)268-04-70

Казахстан +7(7172)727-132

Киргизия +996(312)96-26-47

yne@nt-rt.ru || <https://yuken.nt-rt.ru>

Model Number Designation

F—	CJT210C	—LA	50	B	100	B	—A	B	D	—F	—20
Packing Material	Series Number	Mounting Type	Cylinder Bore mm	Rod Size	Cylinder Stroke mm	Cushion Type	Port Position ^{★2}	Cushion Adj. Valve Position ^{★2}	Air Vent Valve Position ^{★2}	Options ^{★1}	Design Number
None : Nitrile Rubber Rubber (Standard)	CJT210C : 21MPa Series Compact Type Standard Cylinder	SD,LA FA,FB CA,TC	40, 50, 63, 80, 100, 125, 140, 160	A : Rod A B : Rod B	Cylinder Stroke	B : With Cushion on Both ends R : With Cushion on the Rod side H : With Cushion on the Cap side N : Without Cushion	(Viewed from Rod End) A : Upper (Standard) B : Right C : Under D : Left	B : Right (Standard) C : Under D : Left N : No Cushion; adj. valve (Standard)	D : Left (Standard) A : Upper B : Right C : Under	E : With Long Rod End Thread F : With Dust Cover (Material: Nylon Tarpaulin, Heat resistant up to 80°C) G : With Dust Cover (Material: Chloroprene, Heat resistant up to 130°C) H : With Dust Cover (Material: Conex, Heat resistant up to 200°C) K : With Lock Nut (E : Used in combination with long rod end thread) L : With T-End ^{★3} (Rod End Eye) M : With Y-End ^{★3} (Rod End Clevis)	20

★1. Using the options in combination is available. Please specify the option code in the alphabet. Ex.: EKL

★2. As for each direction of port, cushion adj.valve and air vent valve, please select from (A)(B)(C)(D) viewed from rod end(see the figure on the below).
<Standard directions>
Port: (A), Cushion adj.valve: (B), Air vent valve: (D)
The arrangement of the air vent valve and cushion adj. valve is shown in the table below.

Port Position	Cushion Adj. Valve Position	Air Vent Valve Position
A, B, C, D	Except port side	Except port side and cushion adjusting valve side

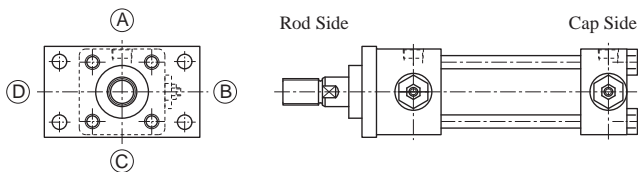

★3. Rod end attachment is for rod size B only. If rod end attachment is used with rod size A, the thread dimensions will be those of rod size B. Moreover, the rod end attachment with lock nut and without lock nut have different fixing method.

- ① With Lock Nut
Lock the rod end attachment with a lock nut since a set screw for fixing is not included.
- ② Without Lock Nut
Locked by set screw for fixing. Rod threads have pointings (drill holes). Please consult us separately for without pointing.

Mounting Type

Code	Name	Illustration of Mounting Type	Code	Name	Illustration of Mounting Type
SD	Basic Type		FB	Cap Rectangular Flange	
LA	Foot Mounting Side Lugs		CA	Cap Detachable Eye	
FA	Rod Rectangular Flange		TC	Intermediate Trunnion	

Syllabus Table

Push (Cap Side Pressure)

Cylinder Bore mm	Pressurized Area cm ²	Output kN				Velocity by a unit flow rate 10L/min mm/s	Flow rate by a unit velocity 10mm/s L/min
		1 MPa	7 MPa	14 MPa	21 MPa		
40	12.6	1.26	8.79	17.58	26.37	132	0.8
50	19.6	1.96	13.74	27.48	41.20	85	1.2
63	31.2	3.12	21.81	43.62	65.41	53	1.9
80	50.3	5.03	35.17	70.34	105.50	33	3.0
100	78.5	7.85	54.95	109.90	164.85	21	4.7
125	122.7	12.27	85.86	171.72	257.46	14	7.4
140	153.9	15.39	107.70	215.40	322.98	10.8	9.2
160	201.0	20.10	140.67	281.34	421.89	8.3	12.1

Pull (Rod Side Pressure)

Cylinder Bore mm	Rod Size Code	Rod Size mm	Pressurized Area cm ²	Output kN				Velocity by a unit flow rate 10L/min mm/s	Flow rate by a unit velocity 10mm/s L/min
				1 MPa	7 MPa	14 MPa	21 MPa		
40	A	28	6.4	0.64	4.46	8.92	13.37	260.5	0.4
	B	22	8.8	0.88	6.13	12.27	18.39	189	0.5
50	A	36	9.4	0.94	6.55	13.10	19.64	177.3	0.6
	B	28	13.5	1.35	8.43	18.86	28.28	123	0.8
63	A	45	15.3	1.53	10.66	21.32	31.97	109	0.9
	B	36	21.0	2.10	14.69	29.38	44.05	79	1.3
80	A	56	25.7	2.57	17.90	35.80	53.71	64.9	1.5
	B	45	34.3	3.43	24.04	48.08	72.11	49	2.1
100	A	70	40.0	4.00	27.86	55.73	83.59	41.7	2.4
	B	56	53.9	5.39	37.72	75.44	113.14	31	3.2
125	A	90	59.1	5.91	41.24	82.34	123.50	28.2	3.5
	B	70	84.2	8.42	58.39	117.87	176.79	20	5.1
140	A	100	75.4	7.54	52.52	105.05	157.57	22.1	4.5
	B	80	103.6	10.36	72.53	145.07	217.56	16	6.2
160	A	110	106.0	10.60	73.84	147.68	221.51	15.7	6.4
	B	90	137.4	13.74	96.16	192.33	288.33	12	8.2

Mass Table

Approx. Mass may be obtained from the formula below.

$$\text{Mass} = \text{A} + [\text{B} \times \text{Stroke}(\text{mm}) / 100] + \text{C} + \text{D}$$

Cylinder Bore mm	Rod Size Code	A Basic Mass SD type	B Additional Mass By A Unit Stroke 100mm	C Basic Mass (Each Mounting)							D Additional Mass		
				LA	FA	FB	CA	CB	TA	TC	T-End (Rod End Eye) L	Y-End (Rod End Clevis) M	Lock Nut K
40	A	4.2	1.2	0.60	0.59	0.88	0.43	0.83	0.18	0.62	—	—	0.18
	B	4.1	1.1	0.59	0.49	0.88	0.42	0.60	0.18	0.62	0.74	1.17	0.12
50	A	7.3	1.9	0.97	1.11	1.69	0.82	1.56	0.28	1.02	—	—	0.36
	B	7.0	1.6	0.97	0.99	1.69	0.80	1.13	0.28	1.02	1.67	2.30	0.18
63	A	11.0	2.8	1.42	1.66	2.68	1.44	2.80	0.62	1.64	—	—	0.81
	B	10.5	2.4	1.42	1.51	2.67	1.40	2.00	0.62	1.64	2.51	3.97	0.36
80	A	18.1	4.3	2.27	2.57	4.29	4.10	4.98	1.29	3.07	—	—	1.48
	B	17.4	3.6	2.25	2.12	4.18	4.08	4.96	1.29	3.07	3.77	6.54	0.81
100	A	28.2	6.5	3.22	4.91	8.18	7.83	9.39	3.22	6.24	—	—	3.10
	B	26.0	5.4	3.21	4.41	8.01	7.86	9.42	3.25	6.24	7.47	12.62	1.48
125	A	51.2	10.3	5.66	7.96	13.52	14.47	17.74	4.96	12.70	—	—	5.80
	B	47.4	8.4	5.56	6.82	13.13	14.55	17.82	4.96	12.70	12.41	22.96	3.10
140	A	73.0	13.1	6.93	8.67	18.01	20.34	24.63	7.64	18.26	—	—	9.60
	B	67.6	10.9	6.93	7.08	17.53	20.45	24.74	7.60	18.26	19.17	33.75	4.42
160	A	100.7	16.6	9.95	13.04	26.79	29.30	35.85	17.49	22.91	—	—	11.14
	B	95.4	14.1	9.95	10.86	26.22	29.49	36.04	17.28	22.91	26.97	46.72	5.80

- Maximum stroke limited by buckling strength
- Calculation of Maximum Stroke

1. Calculate rod end coefficient n from the table on the right.
2. Calculate the maximum installation length L by applying various values such as cylinder bore, rod size, pressure, and rod end coefficient to the figure below.
3. Refer to the external dimensions and calculate the mounting length Lo when retracted.

Use the formula $S=L-L_0$ and calculate the maximum stroke S.
 (Example) Cylinder bore 100 mm, rod size 56 mm, mounting type TC (intermediate trunnion type) standard cylinder operated at 8 MPa pressure. Calculate the maximum stroke. The rod end attachment dimension when calculating the installation length Lo shall be 135 mm.

■ From the table on the right $n=1$
 From the figure below $L \doteq 1980$
 From Dimensional Drawing (J-47) and Rod End Attachment (J-48)
 $L_0 = (180 + 135) + \frac{S}{2}$
 therefore $S = L - L_0 = 1980 - [(180 + 135) + \frac{S}{2}]$
 hence $S \doteq 1110$ mm

Mounting Type	Type	Rod End Coefficient n	Mounting Type	Type	Rod End Coefficient n
LA		1/4	FB		1/4
		2			2
		4			4
FA		1/4	TC		1
		2			
		4	CA		1

$S=L-L_0$
 S : Stroke mm
 L : Mounting Length at extension mm
 Lo : Mounting Length at contraction mm
 Note: For Lo dimensions, refer to dimensional drawing and add the dimensions of rod end attachment.

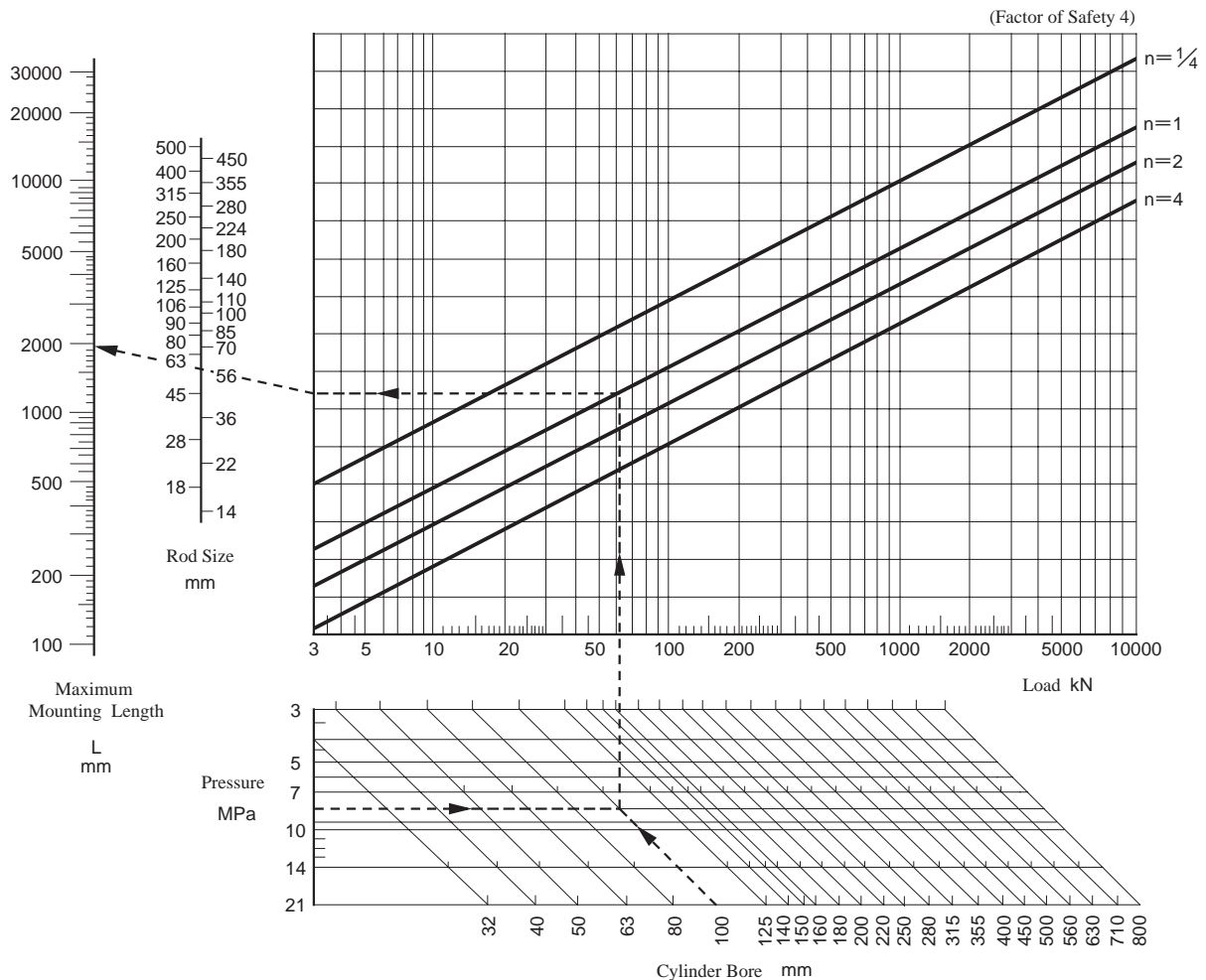

SD : Basic Type

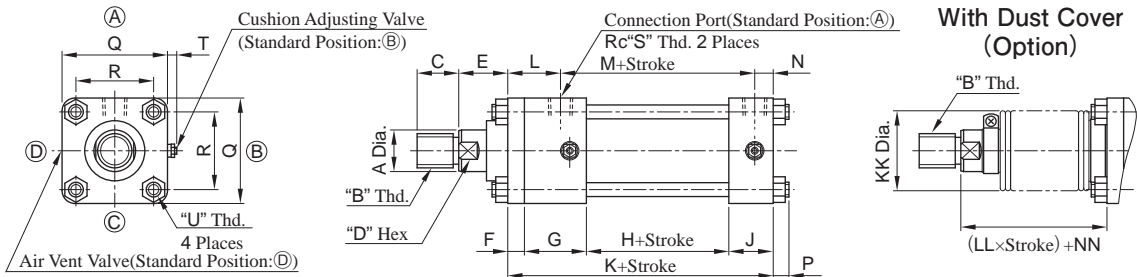

- ★1. Rod size (A Dia.) 90 or larger has two holes for a pin spanner. Cylinder bore 160 the rod B has a rod size 90, but it is hex.
- ★2. Long rod end thread type : the dimension "C" is the value marked in parentheses.

Cylinder Bore	Rod B							Rod A							E	G	H	J	M
	A	B	C*2	D	F	K	L	A	B	C*2	D	F	K	L					
40	22	M20×1.5	25 (45)	19	11	145	38	28	M 24×1.5	30 (50)	24	11	145	38	32	50	48	36	94
50	28	M24×1.5	30 (50)	24	13	162	42	36	M 30×1.5	35 (60)	30	13	162	42	36	56	48	45	102
63	36	M30×1.5	35 (60)	30	15	171	47	45	M 39×1.5	45 (80)	41	15	171	47	43	59	52	45	106
80	45	M39×1.5	45 (80)	41	18	187	57	56	M 48×1.5	55 (95)	50	18	187	57	48	67	54	48	110
100	56	M48×1.5	55 (95)	50	20	192	58	70	M 64×2	75 (125)	65	22	194	60	53	66	60	46	116
125	70	M64×2	75 (125)	65	24	228	73	90	M 80×2	90 (155)	12 Dia.*1	24	228	73	60	82	64	58	130
140	80	M72×2	80 (140)	75	32	244	81	100	M 95×2	105 (185)	12 Dia.*1	32	244	81	60	82	72	58	138
160	90	M80×2	90 (155)	85*1	37	267	86	110	M100×2	110 (190)	15 Dia.*1	37	267	86	60	87	80	63	156

Cylinder Bore	N	P	Q	R	S	T	U	Rod B				Rod A								
								KK	LL		NN	KK	LL		NN					
									Nylon Tarpaulin, Chloroprene	Conex			Nylon Tarpaulin, Chloroprene	Conex						
40	13	11	65	45	3/8	Max.13	M10×1.25	50				45	63	1/3.5	1/2.5	45	63	1/3.5	1/2.5	45
50	18	13	80	56	1/2	Max.13	M12×1.25	63		1/3.5	1/2.5	45	71			45	71	1/4	1/3	55
63	18	14	94	68	1/2	Max.13	M14×1.5	71				55	80			55	80	1/4	1/3	55
80	20	16	114	84	3/4	Max.13	M16×1.5	80		1/4	1/3	55	100			55	100	1/4	1/3	55
100	18	18	135	102	3/4	Max.13	M18×1.5	100				55	125			55	125	1/5	1/3.5	65
125	25	21	165	125	1	Max.13	M22×1.5	125				65	140			65	140			65
140	25	25	192	144	1	Max.13	M27×2	125		1/5	1/3.5	65	160			65	160	1/5	1/4	65
160	25	27	218	164	1	Max.13	M30×2	140			1/4	65	180			65	180			65

LA : Foot Mounting Side Lugs

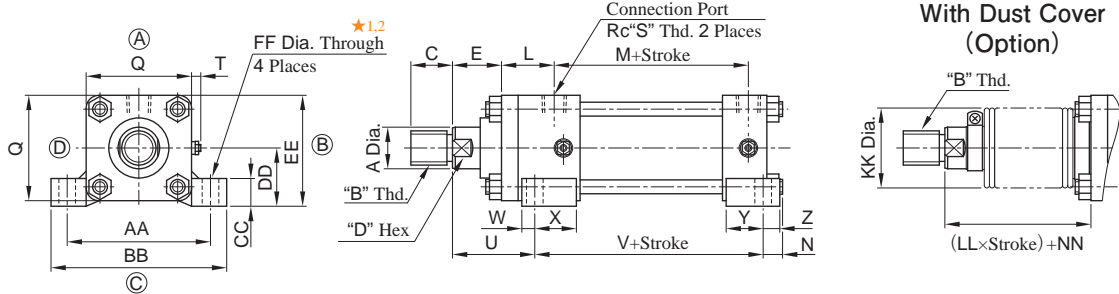

- ★1. The socket head cap screw shall be used as a mounting bolt.
- ★2. As for cylinder bore size 40-100, in case the port direction is (B) or (D), pipe fittings may interfere with cylinder mounting bolts. See Instructions on page J-4 for details.
- ★3. Rod size (A Dia.) 90 or larger has two holes for a pin spanner. Cylinder bore 160 the rod B has a rod size 90, but it is hex.
- ★4. Long rod end thread type : the dimension "C" is the value marked in parentheses.

Cylinder Bore	Rod B							Rod A							M	N	Q	S	T	U	V	W	X
	A	B	C*4	D	E	L	A	B	C*4	D	E	L											
40	22	M20×1.5	25 (45)	19	35	38	28	M 24×1.5	30 (50)	24	35	38	94	27	65	3/8	Max.13	59	105	13	37		
50	28	M24×1.5	30 (50)	24	36	42	36	M 30×1.5	35 (60)	30	36	42	102	31	80	1/2	Max.13	67	113	18	32		
63	36	M30×1.5	35 (60)	30	43	47	45	M 39×1.5	45 (80)	41	43	47	106	29	94	1/2	Max.13	76	123	18	32		
80	45	M39×1.5	45 (80)	41	51	57	56	M 48×1.5	55 (95)	50	51	57	110	24	114	3/4	Max.13	87	143	18	47		
100	56	M48×1.5	55 (95)	50	60	58	70	M 64×2	75 (125)	65	58	60	116	22	135	3/4	Max.13	98	150	18	48		
125	70	M64×2	75 (125)	65	65	73	90	M 80×2	90 (155)	12 Dia.*3	65	73	130	29	165	1	Max.13	112	173	23	59		
140	80	M72×2	80 (140)	75	60	81	100	M 95×2	105 (185)	12 Dia.*3	60	81	138	26	192	1	Max.13	120	183	28	54		
160	90	M80×2	90 (155)	85*3	60	86	110	M100×2	110 (190)	15 Dia.*3	60	86	156	25	218	1	Max.13	127	202	30	57		

Cylinder Bore	Y	Z	AA	BB	CC	DD	EE	FF	Rod B				Rod A								
									KK	LL		NN	KK	LL		NN					
										Nylon Tarpaulin, Chloroprene	Conex			Nylon Tarpaulin, Chloroprene	Conex						
40	16	16	98	122	15	36±0.15	68.5	11	50				48	63	1/3.5	1/2.5	48	63	1/3.5	1/2.5	48
50	27	18	115	145	20	45±0.15	85	14	63		1/3.5	1/2.5	45	71			45	71			45
63	35	15	136	169	25	50±0.15	97	18	71				55	80			55	80	1/4	1/3	55
80	40	18	155	190	30	60±0.25	117	18	80		1/4	1/3	58	100			58	100			58
100	42	18	190	230	35	70±0.25	137.5	22	100				62	125			62	125			62
125	50	23	224	272	45	85±0.25	167.5	26	125				70	140			70	140	1/5	1/3.5	70
140	57	28	262	320	45	100±0.25	196	30	125		1/5	1/3.5	65	160			65	160			65
160	65	30	294	356	55	115±0.25	224	33	140			1/4	65	180			65	180			65

FA : Rod Rectangular Flange

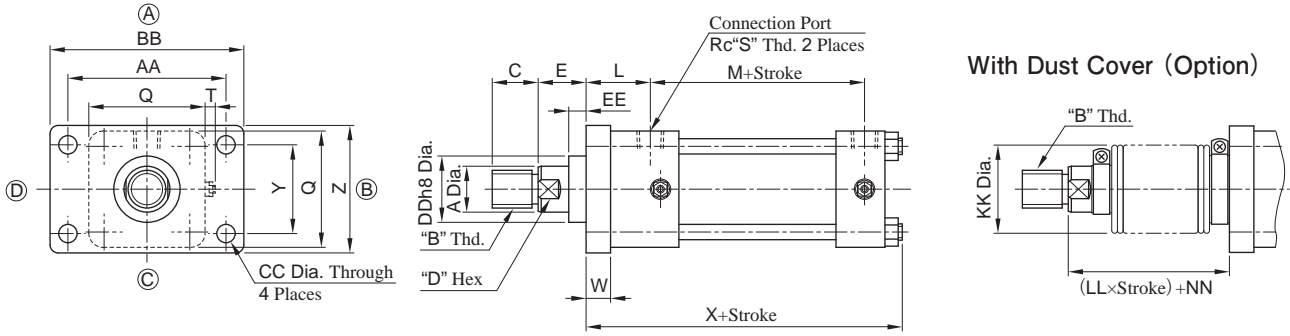

- ★1. Rod size (A Dia.) 90 or larger has two holes for a pin spanner. Cylinder bore 160 the rod B has a rod size 90, but it is hex.
- ★2. Long rod end thread type : the dimension "C" is the value marked in parentheses.

Cylinder Bore	Rod B								Rod A								L	M	Q
	A	B	C*2	D	E	DD	EE	Z	A	B	C*2	D	E	DD	EE	Z			
40	22	M20×1.5	25 (45)	19	28	40	12	73	28	M 24×1.5	30 (50)	24	28	43	11	80	42	94	65
50	28	M24×1.5	30 (50)	24	29	46	9	85	36	M 30×1.5	35 (60)	30	29	55	8	92	49	102	80
63	36	M30×1.5	35 (60)	30	34	55	6	98	45	M 39×1.5	45 (80)	41	34	65	10	105	56	106	94
80	45	M39×1.5	45 (80)	41	42	65	12	125	56	M 48×1.5	55 (95)	50	42	80	13	140	63	110	114
100	56	M48×1.5	55 (95)	50	44	80	6	150	70	M 64×2	75 (125)	65	44	95	12	165	69	116	135
125	70	M64×2	75 (125)	65	47	95	6	175	90	M 80×2	90 (155)	12 Dia.*	47	120	15	195	86	130	165
140	80	M72×2	80 (140)	75	51	105	6	195	100	M 95×2	105 (185)	12 Dia.*	51	130	15	215	90	138	192
160	90	M80×2	90 (155)	85*1	51	120	6	225	110	M100×2	110 (190)	15 Dia.*	51	140	15	245	95	156	218

Cylinder Bore	S	T	W	X	Y	AA	BB	CC	Rod B				Rod A			
									KK	LL		NN	KK	LL		NN
										Nylon Tarpaulin, Chloroprene	Conex			Nylon Tarpaulin, Chloroprene	Conex	
40	3/8	Max.13	15	160	46	95	118	11	50	1/3.5	1/2.5	45	63	1/3.5	1/2.5	45
50	1/2	Max.13	20	182	58	115	145	14	63			45	71			55
63	1/2	Max.13	24	194	65	132	165	18	71	1/4	1/3	55	80	1/4	1/3	55
80	3/4	Max.13	24	209	87	155	190	18	80			55	100			55
100	3/4	Max.13	31	221	109	190	230	22	100	1/5	1/3.5	55	125	1/5	1/3.5	65
125	1	Max.13	37	262	130	224	272	26	125			65	140			65
140	1	Max.13	41	278	145	250	300	30	125	1/4	1/4	65	160	1/4	1/4	65
160	1	Max.13	46	303	170	285	345	33	140			65	180			65

FB : Cap Rectangular Flange

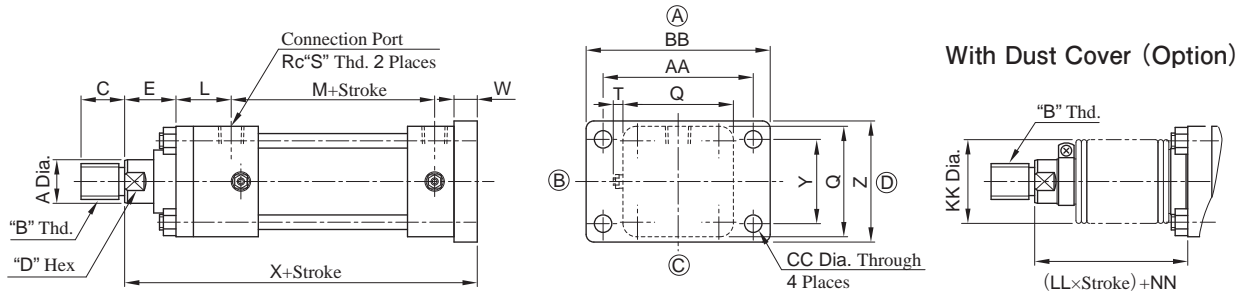

- ★1. Rod size (A Dia.) 90 or larger has two holes for a pin spanner. Cylinder bore 160 the rod B has a rod size 90, but it is hex.
- ★2. Long rod end thread type : the dimension "C" is the value marked in parentheses.

Cylinder Bore	Rod B								Rod A								M	Q	S	T	W	X	Y	Z
	A	B	C*2	D	E	L	A	B	C*2	D	E	L												
40	22	M20×1.5	25 (45)	19	34	38	28	M 24×1.5	30 (50)	24	34	38	94	65	3/8	Max.13	15	194	46	73				
50	28	M24×1.5	30 (50)	24	36	42	36	M 30×1.5	35 (60)	30	36	42	102	80	1/2	Max.13	20	218	58	85				
63	36	M30×1.5	35 (60)	30	46	47	45	M 39×1.5	45 (80)	41	46	47	106	94	1/2	Max.13	24	241	65	98				
80	45	M39×1.5	45 (80)	41	63	57	56	M 48×1.5	55 (95)	50	63	57	110	114	3/4	Max.13	24	274	87	125				
100	56	M48×1.5	55 (95)	50	74	58	70	M 64×2	75 (125)	65	72	60	116	135	3/4	Max.13	31	297	109	150				
125	70	M64×2	75 (125)	65	80	73	90	M 80×2	90 (155)	12 Dia.*	80	73	130	165	1	Max.13	37	345	130	175				
140	80	M72×2	80 (140)	75	82	81	100	M 95×2	105 (185)	12 Dia.*	82	81	138	192	1	Max.13	41	367	145	195				
160	90	M80×2	90 (155)	85*1	83	86	110	M100×2	110 (190)	15 Dia.*	83	86	156	218	1	Max.13	46	396	170	225				

Cylinder Bore	AA	BB	CC	Rod B				Rod A			
				KK	LL		NN	KK	LL		NN
					Nylon Tarpaulin, Chloroprene	Conex			Nylon Tarpaulin, Chloroprene	Conex	
40	95	118	11	50	1/3.5	1/2.5	47	63	1/3.5	1/2.5	47
50	115	145	14	63			45	71			55
63	132	165	18	71	1/4	1/3	58	80	1/4	1/3	58
80	155	190	18	80			70	100			70
100	190	230	22	100	1/5	1/3.5	76	125	1/5	1/3.5	84
125	224	272	26	125			85	140			85
140	250	300	30	125	1/4	1/4	87	160	1/4	1/4	87
160	285	345	33	140			88	180			88

CA : Cap Detachable Eye

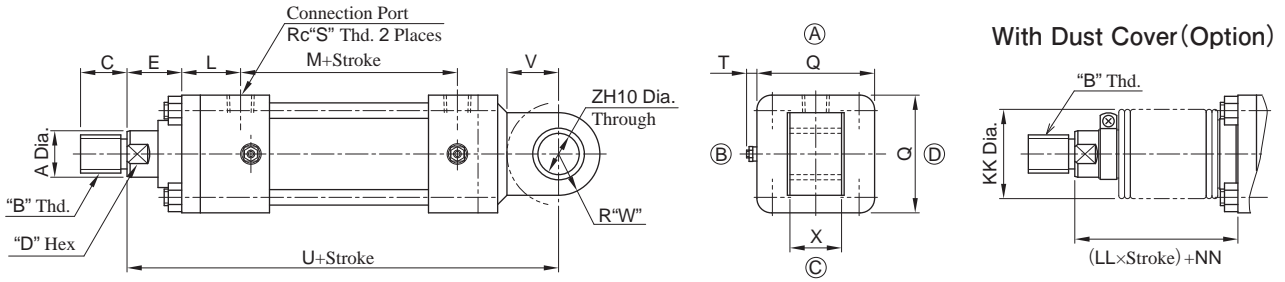

- ★1. Rod size (A Dia.) 90 or larger has two holes for a pin spanner. Cylinder bore 160 the rod B has a rod size 90, but it is hex.
- ★2. Long rod end thread type : the dimension "C" is the value marked in parentheses.

Cylinder Bore	Rod B						Rod A						M	Q	S	T	U	V	W
	A	B	C★2	D	E	L	A	B	C★2	D	E	L							
40	22	M20×1.5	25 (45)	19	38	38	28	M 24×1.5	30 (50)	24	38	38	94	65	3/8	Max.13	214	25	25
50	28	M24×1.5	30 (50)	24	42	42	36	M 30×1.5	35 (60)	30	42	42	102	80	1/2	Max.13	242	32	30
63	36	M30×1.5	35 (60)	30	53	47	45	M 39×1.5	45 (80)	41	53	47	106	94	1/2	Max.13	271	40	35
80	45	M39×1.5	45 (80)	41	51	57	56	M 48×1.5	55 (95)	50	51	57	110	114	3/4	Max.13	316	50	40
100	56	M48×1.5	55 (95)	50	56	58	70	M 64×2	75 (125)	65	54	60	116	135	3/4	Max.13	345	63	50
125	70	M64×2	75 (125)	65	56	73	90	M 80×2	90 (155)	12 Dia★1	56	73	130	165	1	Max.13	398	71	63
140	80	M72×2	80 (140)	75	55	81	100	M 95×2	105 (185)	12 Dia★1	55	81	138	192	1	Max.13	425	80	70
160	90	M80×2	90 (155)	85★1	52	86	110	M100×2	110 (190)	15 Dia★1	52	86	156	218	1	Max.13	460	90	80

Cylinder Bore	X	Z	Rod B				Rod A			
			KK	LL		NN	KK	LL		NN
				Nylon Tarpaulin, Chloroprene	Conex			Nylon Tarpaulin, Chloroprene	Conex	
40	25 ^{-0.1} _{-0.4}	20	50	1/3.5	1/2.5	51	63	1/3.5	1/2.5	51
50	32 ^{-0.1} _{-0.4}	25	63			51	71			61
63	40 ^{-0.1} _{-0.4}	32	71	1/4	1/3	65	80	1/4	1/3	65
80	50 ^{-0.1} _{-0.4}	40	80			58	100			58
100	63 ^{-0.1} _{-0.4}	50	100	1/5	1/3.5	58	125	1/5	1/4	66
125	80 ^{-0.1} _{-0.6}	63	125			61	140			61
140	90 ^{-0.1} _{-0.6}	70	125	1/4	1/4	60	160	1/4	1/4	60
160	100 ^{-0.1} _{-0.6}	80	140			57	180			57

TC : Intermediate Trunnion

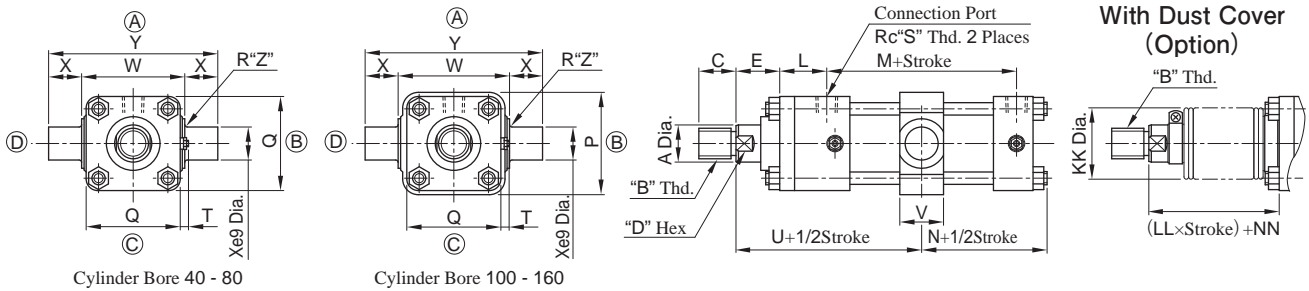

- ★1. Rod size (A Dia.) 90 or larger has two holes for a pin spanner. Cylinder bore 160 the rod B has a rod size 90, but it is hex.
- ★2. Long rod end thread type : the dimension "C" is the value marked in parentheses.

Cylinder Bore	Rod B						Rod A						M	P	Q	S	T	U	V		
	A	B	C★2	D	E	L	A	B	C★2	D	E	L								N	
40	22	M20×1.5	25 (45)	19	32	38	71	28	M 24×1.5	30 (50)	24	32	38	71	94	—	65	3/8	Max.13	117	33
50	28	M24×1.5	30 (50)	24	36	42	82	36	M 30×1.5	35 (60)	30	36	42	82	102	—	80	1/2	Max.13	129	33
63	36	M30×1.5	35 (60)	30	43	47	83.5	45	M 39×1.5	45 (80)	41	43	47	83.5	106	—	94	1/2	Max.13	144.5	43
80	45	M39×1.5	45 (80)	41	41	57	76.5	56	M 48×1.5	55 (95)	50	48	57	83.5	110	—	114	3/4	Max.13	167.5	53
100	56	M48×1.5	55 (95)	50	49	58	79	70	M 64×2	75 (125)	65	53	60	85	116	146	135	3/4	Max.13	180	63
125	70	M64×2	75 (125)	65	53	73	94	90	M 80×2	90 (155)	12 Dia★1	60	73	101	130	185	165	1	Max.13	208	78
140	80	M72×2	80 (140)	75	53	81	101	100	M 95×2	105 (185)	12 Dia★1	60	81	108	138	210	192	1	Max.13	221	88
160	90	M80×2	90 (155)	85★1	53	86	111.5	110	M100×2	110 (190)	15 Dia★1	60	86	118.5	156	230	218	1	Max.13	235.5	98

Cylinder Bore	W	X	Y	Z	Rod B				Rod A			
					KK	LL		NN	KK	LL		NN
						Nylon Tarpaulin, Chloroprene	Conex			Nylon Tarpaulin, Chloroprene	Conex	
40	73 ⁰ _{-0.3}	20	110	2.5	50	1/3.5	1/2.5	45	63	1/3.5	1/2.5	45
50	85 ⁰ _{-0.35}	25	135	2.5	63			45	71			55
63	100 ⁰ _{-0.35}	32	164	2.5	71	1/4	1/3	55	80	1/4	1/3	55
80	125 ⁰ _{-0.4}	40	205	3	80			48	100			55
100	155 ⁰ _{-0.4}	50	255	3	100	1/5	1/3.5	51	125	1/5	1/4	65
125	195 ⁰ _{-0.46}	63	321	4	125			58	140			65
140	220 ⁰ _{-0.46}	70	360	4	125	1/4	1/4	58	160	1/4	1/4	65
160	240 ⁰ _{-0.46}	80	400	4	140			58	180			65

Options

Lock Nut : Option Code "K"

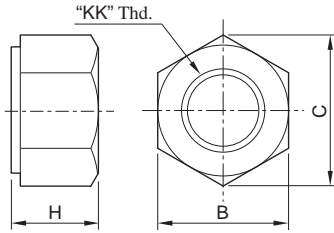

	KK	H	B	C
M20×1.5		18	30	34.6
M24×1.5		20	36	41.6
M30×1.5		25	46	53.1
M39×1.5		32	60	69.3
M48×1.5		38	75	86.6
M64×2		51	95	109.7
M72×2		58	105	121.2
M80×2		64	115	132.8

Rod End Attachment

T-End (Rod End Eye) : Option Code "L"

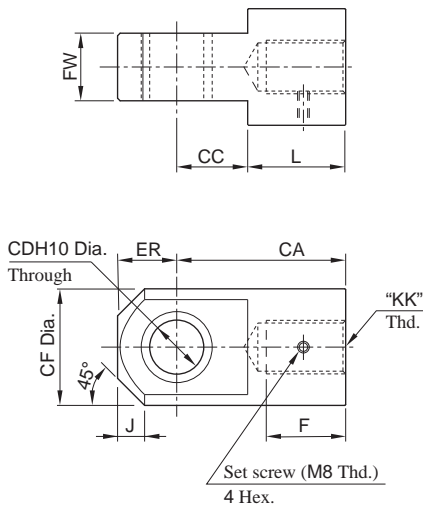

Cylinder Bore	KK	F	CA	CC	CD	CF	ER	FW	J	L
40	M20×1.5	32	70	27	20	45	22.5	25 ^{-0.1} _{-0.4}	8	43
50	M24×1.5	35	80	34	25	55	30	32 ^{-0.1} _{-0.4}	15	46
63	M30×1.5	40	95	42	32	70	35	40 ^{-0.1} _{-0.4}	16	53
80	M39×1.5	53	110	52	40	80	40	50 ^{-0.1} _{-0.4}	15	58
100	M48×1.5	62	135	65	50	98	50	63 ^{-0.1} _{-0.4}	20	70
125	M64×2	80	160	75	63	118	63	80 ^{-0.1} _{-0.6}	30	85
140	M72×2	87	180	82	70	138	70	90 ^{-0.1} _{-0.6}	35	98
160	M80×2	96	195	94	80	158	80	100 ^{-0.1} _{-0.6}	40	101

Y-End (Rod End Clevis): Option Code "M"

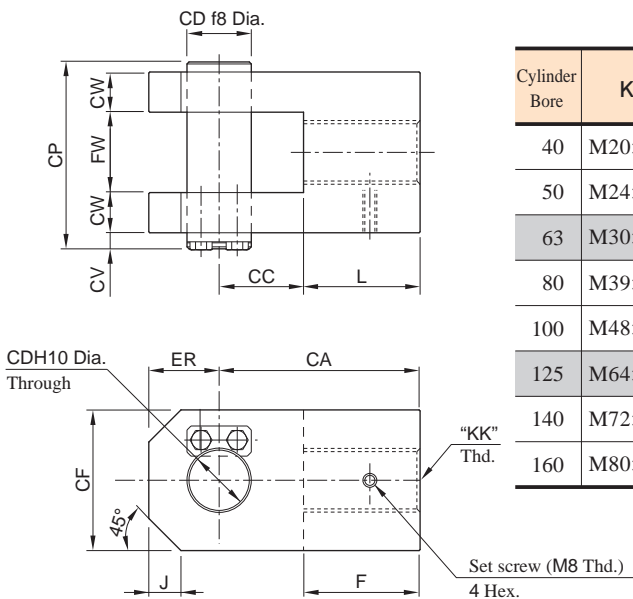

Cylinder Bore	KK	F	CA	CC	CD	CF	ER	FW	CW	CV	CP	J	L
40	M20×1.5	43	70	27	20	45	22.5	25 ^{+0.4} _{+0.1}	12.5	8	63	8	43
50	M24×1.5	46	80	34	25	60	30	32 ^{+0.4} _{+0.1}	16	8	77	15	46
63	M30×1.5	53	95	42	32	70	35	40 ^{+0.4} _{+0.1}	20	8	93	16	53
80	M39×1.5	58	110	52	40	80	40	50 ^{+0.4} _{+0.1}	25	12	117	15	58
100	M48×1.5	70	135	65	50	100	50	63 ^{+0.4} _{+0.1}	31.5	12	143	20	70
125	M64×2	85	160	75	63	120	63	80 ^{+0.6} _{+0.1}	40	18	183	30	85
140	M72×2	98	180	82	70	140	70	80 ^{+0.6} _{+0.1}	45	18	203	35	98
160	M80×2	101	195	94	80	160	80	100 ^{+0.6} _{+0.1}	50	24	230	40	101

★ Rod End Attachment thread size "KK" is available only for rod size B.
When used with rod size A, change to rod size B thread diameter.

List of Seals

CJT 210C

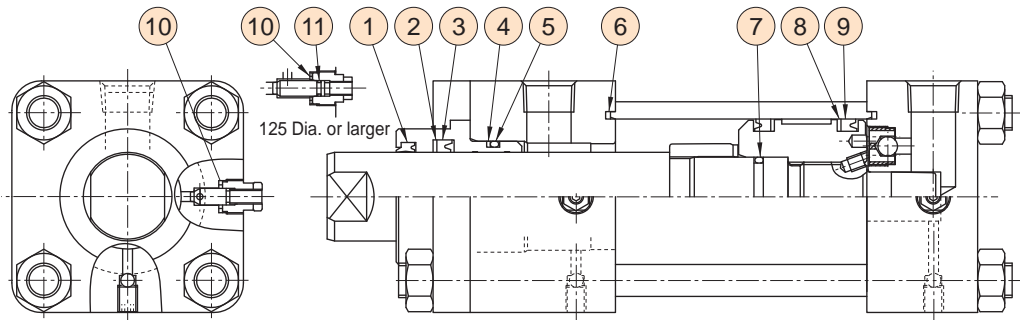

Cylinder Bore	Model Numbers for Seal Kit ^{★1}	Rod B					Rod A				
		Dust Seal ^①	Backup Ring for Rod Packing ^②	Rod Packing ^③	Backup Ring for Bush ^④	O-Ring for Bush ^⑤	Dust Seal ^①	Backup Ring for Rod Packing ^②	Rod Packing ^③	Backup Ring for Bush ^④	O-Ring for Bush ^⑤
40	KS-CJT210C-40*-20	LBH-22	22×30×1	IUH-22A	BUR-G25	G25	LBH-28	28×35.5×1	IUH-28	BUR-G31 ^{★3}	G30
50	KS-CJT210C-50*-20	LBH-28	28×35.5×1	IUH-28	BUR-G31 ^{★3}	G30	LBH-36	36×46×1.5	IUH-36	BUR-G40	G40
63	KS-CJT210C-63*-20	LBH-36	36×46×1.5	IUH-36	BUR-G40	G40	LBH-45	45×56×1.5	IUH-45A	BUR-G55	G55
80	KS-CJT210C-80*-20	LBH-45	45×56×1.5	IUH-45A	BUR-G55	G55	LBH-56	56×66×1.5	IUH-56	BUR-G65	G65
100	KS-CJT210C-100*-20	LBH-56	56×66×1.5	IUH-56	BUR-G65	G65	LBH-70	70×80×1.5	IUH-70	BUR-G80	G80
125	KS-CJT210C-125*-20	LBH-70	70×80×1.5	IUH-70	BUR-G80	G80	LBH-90	90×105×2	IUH-90	BUR-G100	G100
140	KS-CJT210C-140*-20	LBH-80	80×90×1.5	IUH-80	BUR-G90	G90	LBH-100	100×115×2	IUH-100	BUR-G110	G110
160	KS-CJT210C-160*-20	LBH-90	90×105×2	IUH-90	BUR-G100	G100	LBH-110	110×125×2	IUH-110	BUR-G125	G125

Cylinder Bore	Model Numbers for Seal Kit ^{★1}	Cover Seal ^⑥	O-Ring for Piston ^⑦	Backup Ring for Piston Packing ^⑧	Piston Packing ^⑨	Cushion Valve Seal ^⑩	O-Ring for Cushion ^⑪
40	KS-CJT210C-40*-20	TT-40	P16	40×30×1.5	OUHR-40	CX-12H	—
50	KS-CJT210C-50*-20	TT-50	P21	50×40×1.5	OUHR-50	CX-12H	—
63	KS-CJT210C-63*-20	TT-63	G25	63×53×1.5	OUHR-63	CX-12H	—
80	KS-CJT210C-80*-20	TT-80	G35	80×71×2	OUHR-80A	CX-14H	—
100	KS-CJT210C-100*-20	TT-100	G45	100×85×3	OUHR-100	CX-14H	—
125	KS-CJT210C-125*-20	TT-125	G55	125×112×3	OUHR-125	CR-18H	S7
140	KS-CJT210C-140*-20	TT-140	G65	140×125×3	OUHR-140	CR-18H	S7
160	KS-CJT210C-160*-20	TT-160	G75	160×145×3	OUHR-160	CR-18H	S7

Item	Q'ty
①	1
②	1
③	1
④	1
⑤	1
⑥	2
⑦	1
⑧	2
⑨	2
⑩	2
⑪	2

★1. Please indicate rod size A or B in * of the seal kit numbers.

★2. O-rings are the following standards.

Model Numbers	Standard
⑤ O-Ring for Bush	OR NBR-70-1 P(G)* *-N
⑦ O-Ring for Piston	OR NBR-90 P(G)* *-N
⑪ O-Ring for Cushion	Special Standard

★3. Backup rings are made to our standard.

★4. Material of standard packings is Nitrile Rubber. For Fluorocarbon Rubber and Hydrogenated Nitrile Rubber materials, specify the following code after "KS-".

Fluoro rubber: F-, Hydrogenated nitrile rubber: 6-

Note : The packing code changes without notice.

Tie Rod Tightening

When tightening tie rods, do not tighten only one tie rod tightly at a time, but gradually tighten the tie rods in the order of the numbers shown in the figure on the right. Note that one-sided tightening of tie rods may cause operation failure or chattering.

Mounting Type (SD·LA·FA·FB·CA)

Bore mm	40	50	63	80	100	125	140	160
Tightening Torque Nm	41	70	120	170	280	500	880	1100

Mounting Type (TC)

Bore mm	Rod Size	40	50	63	80	100	125	140	160
Tightening Torque Nm	A	41	70	120	200	330	600	1050	1300
	B	41	70	120	170	280	500	880	1100

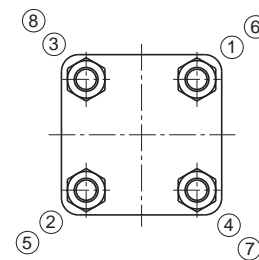

Interchangeability in Installation between Current and New Design

YUKEN's "CJT 21 MPa" series compact type hydraulic cylinders has undergone the following model changes to make it more compact and lightweight, contributing to space saving.

Major Changes

- ① Overall length shortened
- ② Structural Change
 - The cushion structure has been changed for more stable cushioning performance.
 - The conventional structure with a check valve on the outer surface of the cover has been eliminated, and a cushion ring that doubles as a check valve has been adopted on the rod side.
 - A check valve directly connected to the bottom hole of the port is used on the cap side.
 - An air vent valve is installed separately from the check valve to prevent the check valve from being exposed to the outside surface.
 - All cushion adjusting valves have been commonized.
 - Basically, internal parts of current and new products are not interchangeable.

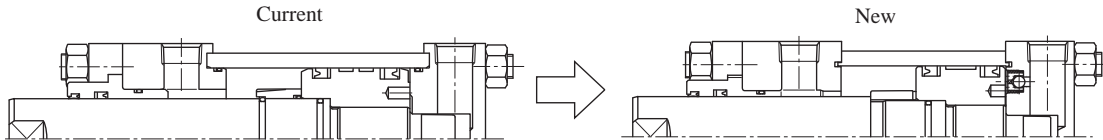

Design Number

Series Number	Change Detail
CJT210C	10 Design to 20 Design

Interchangeability in Installation

The distance between ports and the total length have been changed, but there is no change in the basic installation.

Series Number	Change of port-to-port distance
CJT210C	Pages J-52 to J-53, dimension M.

Please consult us separately for dimensions in "CA" and "TC" Type.

Air Vent Valve

Shape has been changed and unified.

Current	New
<p>Cylinder Bore 40 - 125</p> <p>Valve Seal</p> <p>Tightening Torque : 8 - 10 Nm</p>	<p>Hex. Socket Set Screw</p> <p>Rigid Ball</p> <p>Tightening Torque : 3 - 5 Nm</p>
<p>Cylinder Bore 140,160</p> <p>Valve Seal</p> <p>Tightening Torque : 8 - 10 Nm</p>	

Cushion Adjusting Valve

Unify the shape with current design cylinder bore 40-80.

Current	New
<p>Cylinder Bore 40 - 80</p> <p>Lock Nut</p> <p>Cushion Plug</p> <p>Cushion Adjusting Screw</p> <p>Cushion Adjusting Valve Seal</p> <p>Tightening Torque : 7 - 8 Nm</p> <p>Prescribed lift: from fully closed to end of stroke.</p>	<p>Lock Nut</p> <p>Cushion Plug</p> <p>Cushion Adjusting Screw</p> <p>Cushion Adjusting Valve Seal</p> <p>Tightening Torque : 7 - 8 Nm</p> <p>Prescribed lift: from fully closed to end of stroke.</p>
<p>Cylinder Bore 100 - 160</p> <p>Lock Nut</p> <p>O-Ring</p> <p>Cushion Plug</p> <p>Cushion Adjusting Screw</p> <p>Cushion Adjusting Valve Seal</p> <p>Tightening Torque : 7 - 8 Nm</p> <p>Prescribed lift: from fully closed to end of stroke.</p>	

●Cushion

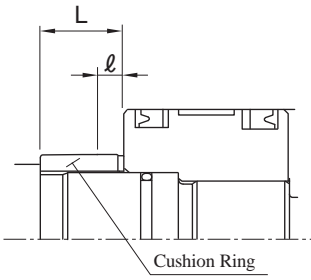

Cushion Length

Cylinder Bore mm	Current		New	
	Cushion Ring Length L mm	Cushion Ring Parallel Part Length ℓ mm	Cushion Ring Length L mm	Cushion Ring Parallel Part Length ℓ mm
40	25	7	26	10
50	25	7	28	10
63	25	7	28	10
80	30	8	30	12
100	30	8	30	12
125	30	8	33	15
140	30	12	33	15
160	30	12	33	15

Note : The cushioning effect will weaken if the cushion ring is not used at the end of the stroke and is stopped more than 5mm before the end of the stroke.

●Specifications

The new and current are identical except for the following.

Cylinder Bore mm	Maximum Stroke	
	Current mm	New mm
40	1500	1600

●Model Number Designation

The notes have been changed along with the model numbers. Refer to page J-42 for the changed notes.

●Mass Table

Mass has been changed in general. Refer to page J-43 for changed mass.

●Option

Y-End(Rod End Clevis) : Option Code "M"

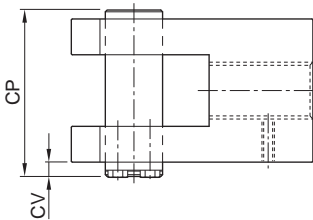

Cylinder Bore	Current		New	
	CV	CP	CV	CP
160	24	230	18	223

●List of Seals

Seals have been changed and deleted. Refer to page J-49 for changes.

①Change: Tail end of Model Numbers

②Change: Cover Seal

Current	New
O-Ring for cover, Back Up Ring for cover	Cover Seal

③Delete: O-Ring for cushion ring and Back Up Ring for cushion ring

④Change: O-Ring dimension for cushion(partial)

⑤Delete: Check Valve Seal

●Foot Mounting Side Lugs (LA Type) Piping Precautions

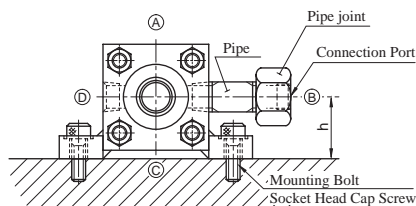

Cylinder Bore	h	
	Current	New
40	36	41
50	45	51
63	56	56
80	60	70
100	80	80

● **Dimensions**

The new and current are identical except for the following dimensions.

CJT210C-SD

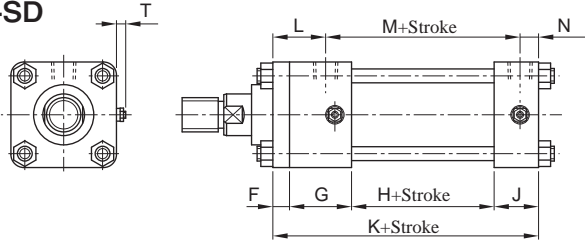

Cylinder Bore	Current									New								
	F Rod A	G	H	J	K	M	N	L	T	F Rod A	G	H	J	K	M	N	L	T
40	11	43	62	31	147	94	15	38	Max.10	11	50	48	36	145	94	13	38	Max.13
50	13	47	66	36	162	102	18	42	Max.10	13	56	48	45	162	102	18	42	Max.13
63	15	50	73	36	174	109	18	47	Max.10	15	59	52	45	171	106	18	47	Max.13
80	18	60	83	41	202	125	20	57	Max.10	18	67	54	48	187	110	20	57	Max.13
100	22	60	90	41	213	132	20	61	Max.11	20	66	60	46	192	116	18	57	Max.13
125	24	75	98	51	248	150	25	73	Max.11	24	82	64	58	228	130	25	73	Max.13
140	32	75	108	51	266	160	25	81	Max.13	32	82	72	58	244	138	25	81	Max.13
160	37	106	127	51	290	179	25	86	Max.13	37	87	80	63	267	156	25	86	Max.13

CJT210C-LA

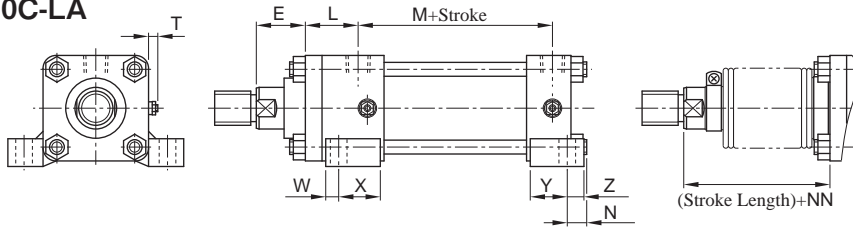

Cylinder Bore	Current										New									
	E	L	M	N	T	W	X	Y	Z	NN	E	L	M	N	T	W	X	Y	Z	NN
40	32	38	94	26	Max.10	16	27	16	15	45	35	38	94	27	Max.13	13	37	16	16	48
50	36	42	102	31	Max.10	18	29	18	18	45	36	42	102	31	Max.13	18	32	27	18	55
63	43	47	109	32	Max.10	18	32	18	18	55	43	47	106	29	Max.13	18	32	35	15	55
80	48	57	125	36	Max.10	21	39	21	20	55	51	57	110	24	Max.13	18	47	40	18	58
100	53	61	132	36	Max.11	23	37	23	18	55	Rod B 60 Rod A 58	Rod B 58 Rod A 60	116	22	Max.13	18	48	42	18	Rod B 62 Rod A 70
125	60	73	150	44	Max.11	28	47	28	23	65	65	73	130	29	Max.13	23	59	50	23	70
140	60	81	160	53	Max.13	28	47	28	28	65	60	81	138	26	Max.13	28	54	57	28	65
160	60	86	179	57	Max.13	30	45	30	30	65	60	86	156	25	Max.13	30	57	65	30	65

CJT210C-FA

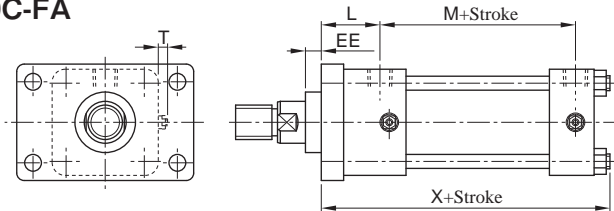

Cylinder Bore	Current						New					
	L	M	T	X	EE		L	M	T	X	EE	
					Rod B	Rod A					Rod B	Rod A
40	42	94	Max.10	162	7	11	42	94	Max.13	160	12	11
50	49	102	Max.10	182	6	8	49	102	Max.13	182	9	8
63	56	109	Max.10	197	6	10	56	106	Max.13	194	6	10
80	63	125	Max.10	224	6	13	63	110	Max.13	209	12	13
100	70	132	Max.11	240	6	10	69	116	Max.13	221	6	12
125	86	150	Max.11	282	6	15	86	130	Max.13	262	6	15
140	90	160	Max.13	300	6	15	90	138	Max.13	278	6	15
160	95	179	Max.13	326	6	15	95	156	Max.13	303	6	15

CJT210C-FB

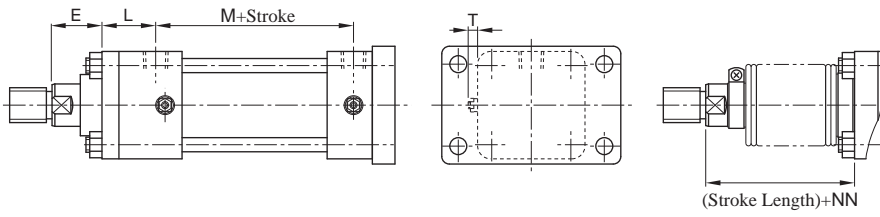

Cylinder Bore	Current						New					
	E	L	M	T	NN		E	L	M	T	NN	
					Rod B	Rod A					Rod B	Rod A
40	32	38	94	Max.10	45	45	34	38	94	Max.13	47	47
50	36	42	102	Max.10	45	55	36	42	102	Max.13	45	55
63	43	47	109	Max.10	55	55	46	47	106	Max.13	58	58
80	48	57	125	Max.10	55	55	63	57	110	Max.13	70	70
100	53	61	132	Max.11	55	65	Rod B 74 Rod A 72	Rod B 58 Rod A 60	116	Max.13	76	84
125	60	73	150	Max.11	65	65	80	73	130	Max.13	85	85
140	60	81	160	Max.13	65	65	82	81	138	Max.13	87	87
160	60	86	179	Max.13	65	65	83	86	156	Max.13	88	88

CJT210C-CA

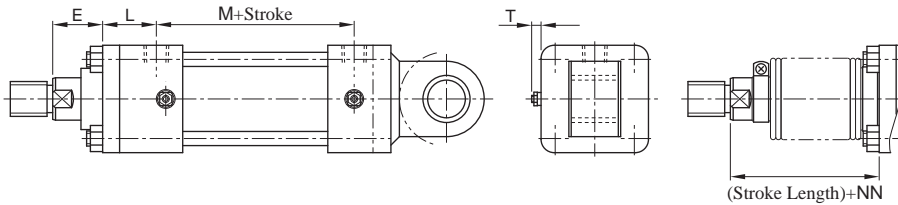

Cylinder Bore	Current						New					
	E	L	M	T	NN		E	L	M	T	NN	
					Rod B	Rod A					Rod B	Rod A
40	32	38	94	Max.10	45	45	38	38	94	Max.13	51	51
50	36	42	102	Max.10	45	55	42	42	102	Max.13	51	61
63	43	47	109	Max.10	55	55	53	47	106	Max.13	65	65
80	48	57	125	Max.10	55	55	51	57	110	Max.13	58	58
100	53	61	132	Max.11	55	65	Rod B 56 Rod A 54	Rod B 58 Rod A 60	116	Max.13	58	66
125	60	73	150	Max.11	65	65	56	73	130	Max.13	61	61
140	60	81	160	Max.13	65	65	55	81	138	Max.13	60	60
160	60	86	179	Max.13	65	65	52	86	156	Max.13	57	57

CJT210C-TC

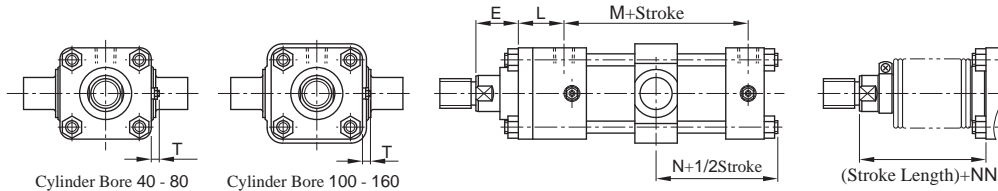

Cylinder Bore	Current						New						
	E Rod B	L	M	T	N	NN Rod B	E Rod B	L	M	T	N		NN Rod B
											Rod B	Rod A	
40	32	38	94	Max.10	73	45	32	38	94	Max.13	71	71	45
50	36	42	102	Max.10	82	45	36	42	102	Max.13	82	82	45
63	43	47	109	Max.10	86.5	55	43	47	106	Max.13	83.5	83.5	55
80	48	57	125	Max.10	98.5	55	41	57	110	Max.13	76.5	83.5	48
100	53	61	132	Max.11	104	55	49	Rod B 58 Rod A 60	116	Max.13	79	85	51
125	60	73	150	Max.11	121	65	53	73	130	Max.13	94	101	58
140	60	81	160	Max.13	130	65	53	81	138	Max.13	101	108	58
160	60	86	179	Max.13	141.5	65	53	86	156	Max.13	111.5	118.5	58

По вопросам продаж и поддержки обращайтесь:

Алматы (7273)495-231	Калининград (4012)72-03-81	Омск (3812)21-46-40	Сыктывкар (8212)25-95-17
Ангарск (3955)60-70-56	Калуга (4842)92-23-67	Орел (4862)44-53-42	Тамбов (4752)50-40-97
Архангельск (8182)63-90-72	Кемерово (3842)65-04-62	Оренбург (3532)37-68-04	Тверь (4822)63-31-35
Астрахань (8512)99-46-04	Киров (8332)68-02-04	Пенза (8412)22-31-16	Тольятти (8482)63-91-07
Барнаул (3852)73-04-60	Коломна (4966)23-41-49	Пермь (342)205-81-47	Томск (3822)98-41-53
Белгород (4722)40-23-64	Кострома (4942)77-07-48	Петрозаводск (8142)55-98-37	Тула (4872)33-79-87
Благовещенск (4162)22-76-07	Краснодар (861)203-40-90	Псков (8112)59-10-37	Тюмень (3452)66-21-18
Брянск (4832)59-03-52	Красноярск (391)204-63-61	Ростов-на-Дону (863)308-18-15	Улан-Удэ (3012)59-97-51
Владивосток (423)249-28-31	Курган (3522)50-90-47	Рязань (4912)46-61-64	Ульяновск (8422)24-23-59
Владикавказ (8672)28-90-48	Курск (4712)77-13-04	Самара (846)206-03-16	Уфа (347)229-48-12
Владимир (4922)49-43-18	Липецк (4742)52-20-81	Санкт-Петербург (812)309-46-40	Хабаровск (4212)92-98-04
Волгоград (844)278-03-48	Магнитогорск (3519)55-03-13	Саранск (8342)22-96-24	Чебоксары (8352)28-53-07
Вологда (8172)26-41-59	Москва (495)268-04-70	Саратов (845)249-38-78	Челябинск (351)202-03-61
Воронеж (473)204-51-73	Мурманск (8152)59-64-93	Севастополь (8692)22-31-93	Череповец (8202)49-02-64
Екатеринбург (343)384-55-89	Набережные Челны (8552)20-53-41	Симферополь (3652)67-13-56	Чита (3022)38-34-83
Иваново (4932)77-34-06	Нижний Новгород (831)429-08-12	Смоленск (4812)29-41-54	Якутск (4112)23-90-97
Ижевск (3412)26-03-58	Новокузнецк (3843)20-46-81	Сочи (862)225-72-31	Ярославль (4852)69-52-93
Иркутск (395)279-98-46	Новосибирск (383)227-86-73	Ставрополь (8652)20-65-13	
Казань (843)206-01-48	Ноябрьск (3496)41-32-12	Сургут (3462)77-98-35	

Россия +7(495)268-04-70

Казахстан +7(7172)727-132

Киргизия +996(312)96-26-47

yne@nt-rt.ru || <https://yuken.nt-rt.ru>