

# Low Noise Type Pilot Operated Relief Valves

Pilot operated relief valves here have been particularly developed as low-noise types. Able to protect pumps and control valves against excessive pressures, they are used to control the pressure in the hydraulic system to a constant level.

Remote control and unloading are permitted by using vent circuits.

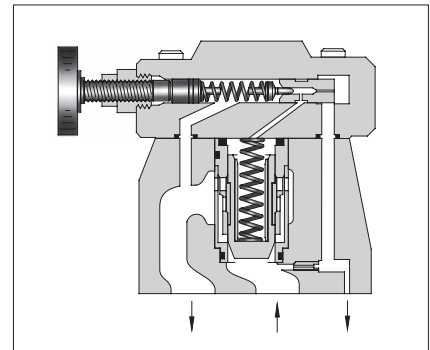

## Specifications

Model Numbers	Max. Operating Pres. MPa	Pres. Adj. Range MPa	Max. Flow L/min	Approx. Mass kg
S-BG-03- *- *-40	25	★ - 25	100	4.1
S-BG-06- *- *-40			200	5.0
S-BG-10- *- *-40			400	10.5

★ See minimum adjustment pressure characteristics on page C-12.

## Model Number Designation

S—	B	G	—03	—V	—L	—40
Low Noise Type	Series Number	Type of Mounting	Valve Size	High Venting Pres. Feature★	Direction of Handle	Design Number
S : Low Noise Type	B : Pilot Operated Relief Valves	G : Sub-plate Mounting	03	V : For High Venting Pressure Feature (Omit if not required)	(Viewed from pressure gauge connection) L: Left (Normal) R: Right	40
			06			40
			10			40

### Graphic Symbols

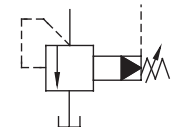
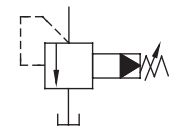

Vent Connection

★ Use the high venting pressure type where it is necessary to reduce the changeover time from unloading to onloading.

We also product The Low Noise Type Solenoid Controlled Relief Valves as below. For more details, please contact us.

Model Numbers	Max. Operating Pres. MPa	Max. Flow L/min
S-BSG-03- *- *- *- *-53	25	100
S-BSG-06- *- *- *- *- *-53		200
S-BSG-10- *- *- *- *- *-53		400

## Accessories

### Mounting Bolts

Valve Model Numbers	Socket Head Cap Screw
S-BG-03	M12×40L ..... 4 Pcs.
S-BG-06	M16×50L ..... 4 Pcs.
S-BG-10	M20×60L ..... 4 Pcs.

## Instructions

- If a remote control relief valve is used in the vent circuit, see page C-5. In addition, if the internal volume of the vent line is too large, chattering is likely to occur. Thus, as far as possible reduce the inside diameter and the length of the pipe.
- To adjust the pressure, loosen the lock nut and turn the handle slowly clockwise for higher pressures or anti-clockwise for lower pressures. After adjustments, do not forget to tighten the lock nut.
- Piping of the tank line should not be connected to any tank line of the other valves, but connected directly to the reservoir.
- With a small flow, the setting pressure may be unstable. Use with minimum flow rate as the table below.

Valve Size	Min. Flow
03	5 L/min
06	
10	8 L/min

## Sub-plates

Valve Model Numbers	Sub-plate Model Numbers	Thread Size Rc	Approx. Mass kg
S-BG-03	BGM-03-20	3/8	2.4
	BGM-03X-20	1/2	3.1
S-BG-06	BGM-06-20	3/4	4.7
	BGM-06X-20	1	5.7
S-BG-10	BGM-10-20	1 1/4	8.4
	BGM-10X-20	1 1/2	10.3

- Sub-plates are available. Specify the sub-plate model number from the table above. When sub-plates are not used, the mounting surface should have a good machined finish. (1/6)
- The sub-plates are those for pilot operated relief valves. For dimensions, see page C-9.

**S-BG-03-06- \*-L-40**  
**S-BG-10- \*-40**

★ Pressure is limited by collars fitted. If a working pressure cannot be attained, remove some collars. One collar is equivalent to 10 MPa.

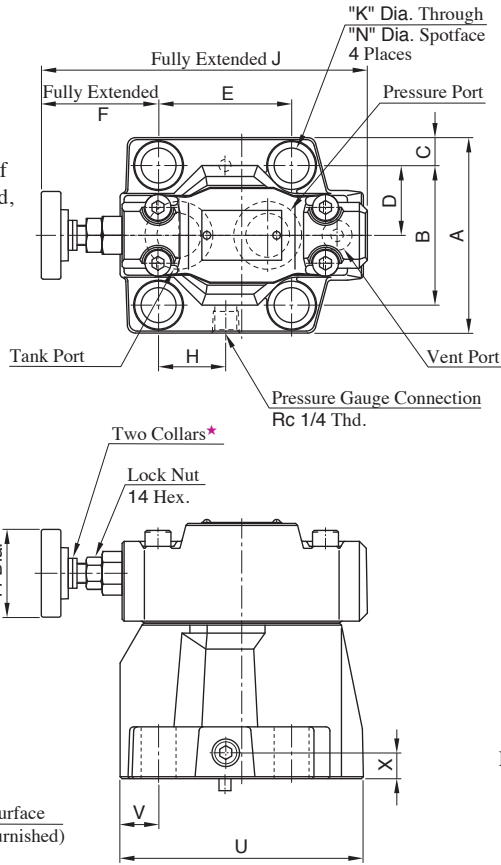

**Mounting Surface**  
 S-BG-03 : ISO 6264-06-09-1-97  
 S-BG-06 : ISO 6264-08-13-1-97  
 S-BG-10 : ISO 6264-10-17-1-97

**Opposite Handle Position**

**S-BG-03-06- \*-R**

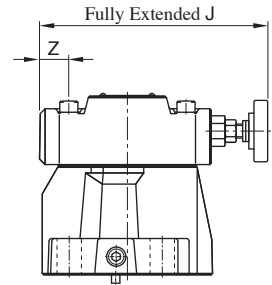

For other dimensions, see the figures shown left.

Note: For dimensions of the valve mounting surface, see the dimensional drawing (Page C-9) of the sub-plate used together.

Model Numbers	A	B	C	D	E	F	H	J	K	N	P	Q	S	T	U	V	X	Z
S-BG-03	76	53.8	11.1	26.9	53.8	73.6	26.9	163.5	13.5	21	50	130	103	21.5	106	26.1	13	36.1
S-BG-06	98	70	14	35	66.7	58.8	33.7	163.5	17.5	26	50	130	103	26	122	19.3	13	21.3
S-BG-10	120	82.6	18.7	41.3	88.9	46.1	44.9	180	21.5	32	65	167	135	33.5	155	21.1	18	—

**Nominal Override Characteristics**

Hydraulic Fluid : Viscosity : 35 mm<sup>2</sup>/s  
 Specific Gravity : 0.850

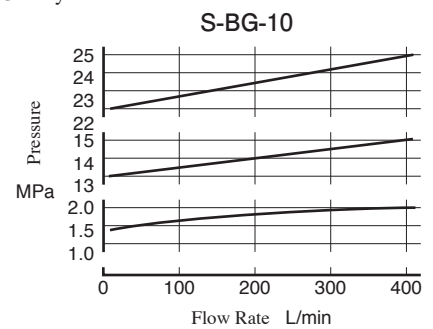
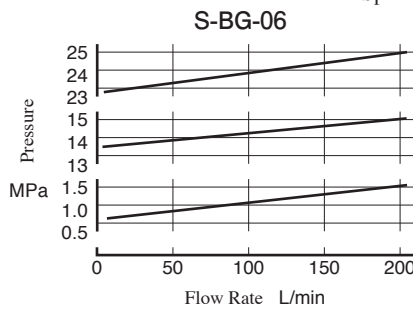
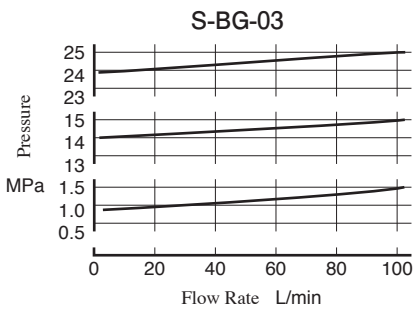

**Min. Adj. Pressure and Vent Pressure vs. Flow**

Hydraulic Fluid: Viscosity : 35 mm<sup>2</sup>/s  
 Specific Gravity : 0.850

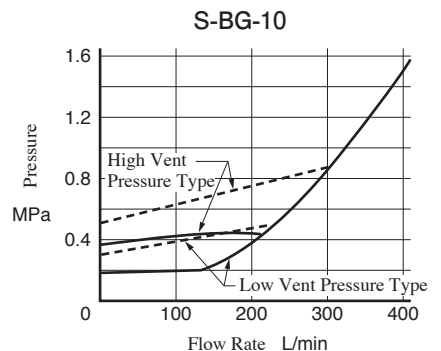
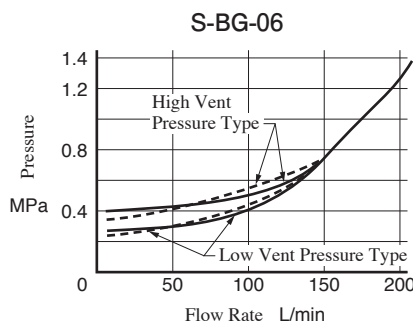
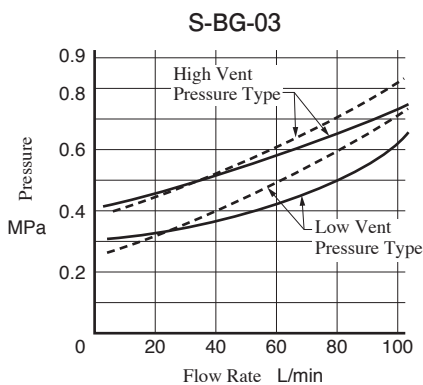

Note: Vent Pressure means the relief pressure when the vent part open to the tank line.

**Noise Level** Measuring Condition  
 Back Pressure : 0.1 MPa Viscosity : 35 mm<sup>2</sup>/s Measuring Position : At 1m back from the valve front.

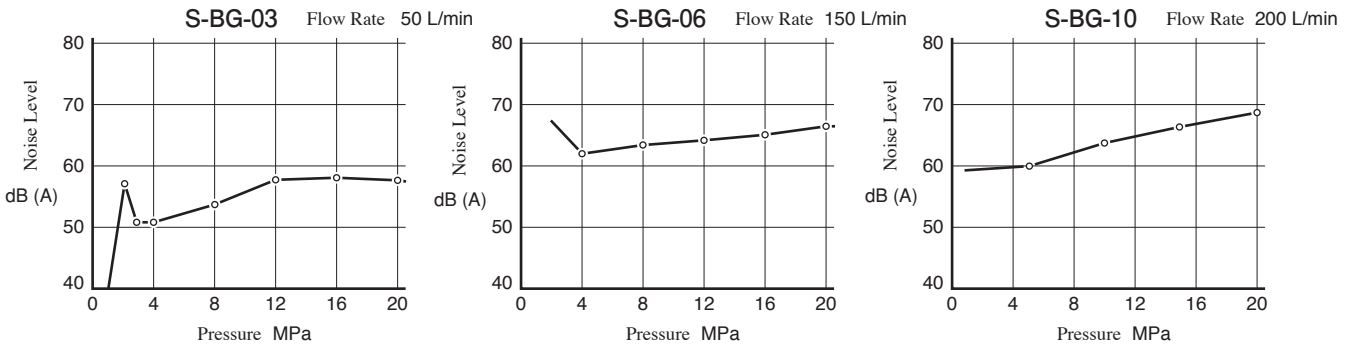

**List of Seals**

**S-BG-03, 06, 10**

Item	Name of Parts	Part Numbers			Qty.
		S-BG-03	S-BG-06	S-BG-10	
25	O-Ring	OR NBR-90 P9-N	OR NBR-90 P9-N	OR NBR-90 P9-N	2
26	O-Ring	OR NBR-70-1 P9-N	OR NBR-70-1 P9-N	OR NBR-70-1 P9-N	1
27	O-Ring	OR NBR-90 P9-N	OR NBR-90 P11-N	OR NBR-90 P9-N	1
28	O-Ring	OR NBR-90 P18-N	OR NBR-90 P28-N	OR NBR-90 P32-N	2
29	O-Ring	AS 568-024 (NBR-90)	AS 568-024 (NBR-90)	AS 568-128 (NBR-90)	1
30	O-Ring	OR NBR-90 P28-N	OR NBR-90 P28-N	OR NBR-90 P36-N	1
31	O-Ring	OR NBR-90 P32-N	OR NBR-90 P32-N	OR NBR-90 P42-N	1
32	O-Ring			OR NBR-90 P14-N	1

**Interchangeability Between Conventional Type and Low Noise Type**

The 40 design of low noise type S-BG-03, 06, 10 has mounting interchangeability with the 32 design of conventional type BG-03, 06, 10. But the outside shape is different, for example the direction of pressure adjustment handle.

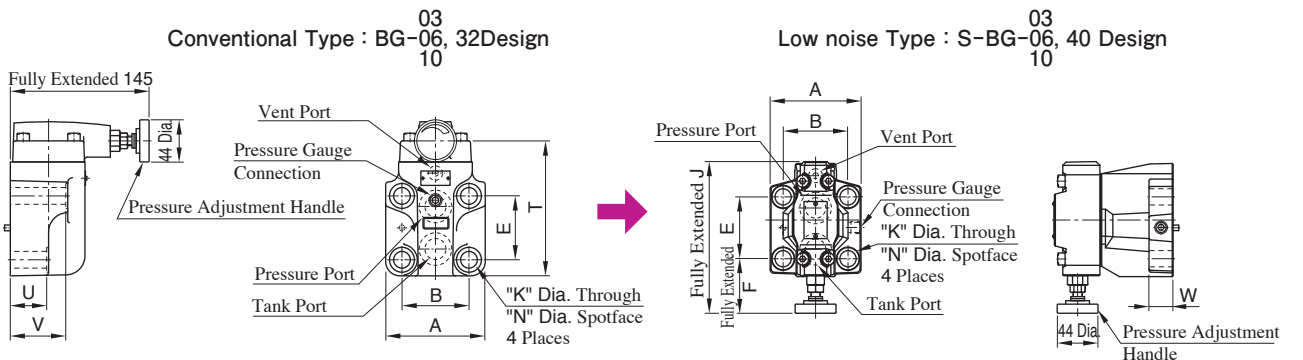

Model Numbers	A	B	E	K	N	T	U	V
BG-03	82	53.8	53.8	13.5	21	117	55	78
BG-06	104	70	66.7	17.5	26	141	38	58
BG-10	124	82.6	88.9	21.5	32	175	45	65

Model Numbers	A	B	E	F	K	N	J	W
S-BG-03	76	53.8	53.8	73.6	13.5	21	163.5	20.5
S-BG-06	98	70	66.7	58.8	17.5	26	163.5	25
S-BG-10	120	82.6	88.9	50.6	21.5	32	180	32.5

**По вопросам продаж и поддержки обращайтесь:**

**Алматы** (7273)495-231  
**Ангарск** (3955)60-70-56  
**Архангельск** (8182)63-90-72  
**Астрахань** (8512)99-46-04  
**Барнаул** (3852)73-04-60  
**Белгород** (4722)40-23-64  
**Благовещенск** (4162)22-76-07  
**Брянск** (4832)59-03-52  
**Владивосток** (423)249-28-31  
**Владикавказ** (8672)28-90-48  
**Владимир** (4922)49-43-18  
**Волгоград** (844)278-03-48  
**Вологда** (8172)26-41-59  
**Воронеж** (473)204-51-73  
**Екатеринбург** (343)384-55-89  
**Иваново** (4932)77-34-06  
**Ижевск** (3412)26-03-58  
**Иркутск** (395)279-98-46  
**Казань** (843)206-01-48

**Калининград** (4012)72-03-81  
**Калуга** (4842)92-23-67  
**Кемерово** (3842)65-04-62  
**Киров** (8332)68-02-04  
**Коломна** (4966)23-41-49  
**Кострома** (4942)77-07-48  
**Краснодар** (861)203-40-90  
**Красноярск** (391)204-63-61  
**Курган** (3522)50-90-47  
**Курск** (4712)77-13-04  
**Липецк** (4742)52-20-81  
**Магнитогорск** (3519)55-03-13  
**Москва** (495)268-04-70  
**Мурманск** (8152)59-64-93  
**Набережные Челны** (8552)20-53-41  
**Нижний Новгород** (831)429-08-12  
**Новокузнецк** (3843)20-46-81  
**Новосибирск** (383)227-86-73  
**Ноябрьск** (3496)41-32-12

**Омск** (3812)21-46-40  
**Орел** (4862)44-53-42  
**Оренбург** (3532)37-68-04  
**Пенза** (8412)22-31-16  
**Пермь** (342)205-81-47  
**Петрозаводск** (8142)55-98-37  
**Псков** (8112)59-10-37  
**Ростов-на-Дону** (863)308-18-15  
**Рязань** (4912)46-61-64  
**Самара** (846)206-03-16  
**Санкт-Петербург** (812)309-46-40  
**Саранск** (8342)22-96-24  
**Саратов** (845)249-38-78  
**Севастополь** (8692)22-31-93  
**Симферополь** (3652)67-13-56  
**Смоленск** (4812)29-41-54  
**Сочи** (862)225-72-31  
**Ставрополь** (8652)20-65-13  
**Сургут** (3462)77-98-35

**Сыктывкар** (8212)25-95-17  
**Тамбов** (4752)50-40-97  
**Тверь** (4822)63-31-35  
**Тольятти** (8482)63-91-07  
**Томск** (3822)98-41-53  
**Тула** (4872)33-79-87  
**Тюмень** (3452)66-21-18  
**Улан-Удэ** (3012)59-97-51  
**Ульяновск** (8422)24-23-59  
**Уфа** (347)229-48-12  
**Хабаровск** (4212)92-98-04  
**Чебоксары** (8352)28-53-07  
**Челябинск** (351)202-03-61  
**Череповец** (8202)49-02-64  
**Чита** (3022)38-34-83  
**Якутск** (4112)23-90-97  
**Ярославль** (4852)69-52-93

Россия +7(495)268-04-70

Казахстан +7(7172)727-132

Киргизия +996(312)96-26-47

yne@nt-rt.ru || <https://yuken.nt-rt.ru>