

Direct type High-Speed Linear Servo Valves

Direct type high speed linear servo valves use a compact and powerful linear motor as an actuator and have an extremely simple structure that connects the linear motor moving coil, the spool, and the position sensor in series.

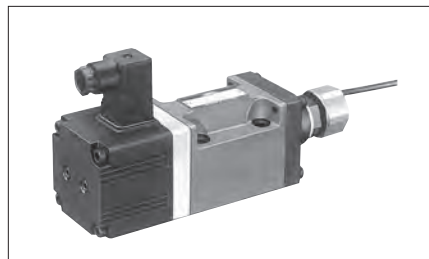

● High accuracy

These valves have a low hysteresis of 0.1 % or less, achieving high accuracy. They allow the main unit to operate with much higher repeatability.

● High response characteristics

The valves provide significantly high levels of step and frequency responses, which are typically used as measures of response characteristics; the step response is 2 ms (0 <=> 100 %)★, and the frequency response is 450 Hz/-90° (±25 % amplitude)★. Thus, the valves ensure that the main unit can achieve unprecedented high response. (★: Representative values)

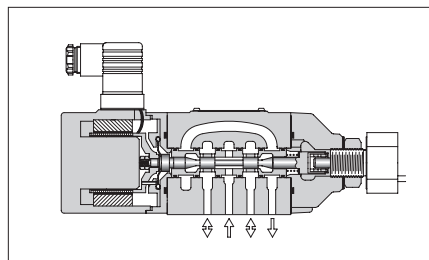

● Excellent vibration-proof characteristics

With a simple structure, the valves offer high vibration resistance.

● Excellent contamination resistance

The valves are also featured by excellent contamination resistance since they have a simple structure that directly connects the linear motor moving coil, the spool, and the position sensor. Compared to conventional servo valves for which the permissible contamination level is up to NAS 1638 class 7, the direct type linear servo valves can accept a contamination level of up to NAS 1638 class 10. These valves can contribute to greatly reducing the cost of fluid management.

Graphic Symbols

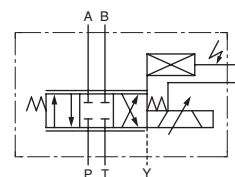

■ Model Number Designation

F—	LSVG	—03	—40	—R	—10
Fluid Type	Series Number	Valve Size	Rated Flow @ ΔP = 7 MPa	Cable Departure Direction	Design Number
F : Special Seals for Phosphate Ester Type Fluid (Omit if not required)	LSVG : Direct Type High Speed Linear Servo Valves	03	4 : 4 L/min 10 : 10 L/min 20 : 20 L/min 40 : 40 L/min 60 : 60 L/min	(Viewed from the linear motor side) None : Upper (Standard) R : Right L : Left	10

■ Exclusive Amplifiers

To ensure stable performance, it is recommended to use Yuken's AMLS series linear servo amplifiers.

Valve Model Number	Amplifier Model
LSVG-03-4/10/20/40	AMLS-A-D * - * -10
LSVG-03-60	AMLS-B-D * - * -10

■ Accessories

Mounting Bolt	Bolt Tightening Torque
Hex. Soc. Head Cap Screw: M8×65L...4 Pieces	30.8 - 37.7 Nm

По вопросам продаж и поддержки обращайтесь:

Алматы (7273)495-231
Ангарск (3955)60-70-56
Архангельск (8182)63-90-72
Астрахань (8512)99-46-04
Барнаул (3852)73-04-60
Белгород (4722)40-23-64
Благовещенск (4162)22-76-07
Брянск (4832)59-03-52
Владивосток (423)249-28-31
Владикавказ (8672)28-90-48
Владимир (4922)49-43-18
Волгоград (844)278-03-48
Вологда (8172)26-41-59
Воронеж (473)204-51-73
Екатеринбург (343)384-55-89

Иваново (4932)77-34-06
Ижевск (3412)26-03-58
Иркутск (395)279-98-46
Казань (843)206-01-48
Калининград (4012)72-03-81
Калуга (4842)92-23-67
Кемерово (3842)65-04-62
Киров (8332)68-02-04
Коломна (4966)23-41-49
Кострома (4942)77-07-48
Краснодар (861)203-40-90
Красноярск (391)204-63-61
Курган (3522)50-90-47
Курск (4712)77-13-04
Липецк (4742)52-20-81

Магнитогорск (3519)55-03-13
Москва (495)268-04-70
Мурманск (8152)59-64-93
Набережные Челны (8552)20-53-41
Нижний Новгород (831)429-08-12
Новокузнецк (3843)20-46-81
Новосибирск (383)227-86-73
Ноябрьск (3496)41-32-12
Омск (3812)21-46-40
Орел (4862)44-53-42
Оренбург (3532)37-68-04
Пенза (8412)22-31-16
Пермь (342)205-81-47
Петрозаводск (8142)55-98-37
Псков (8112)59-10-37

Ростов-на-Дону (863)308-18-15
Рязань (4912)46-61-64
Самара (846)206-03-16
Санкт-Петербург (812)309-46-40
Саранск (8342)22-96-24
Саратов (845)249-38-78
Севастополь (8692)22-31-93
Симферополь (3652)67-13-56
Смоленск (4812)29-41-54
Сочи (862)225-72-31
Ставрополь (8652)20-65-13
Сургут (3462)77-98-35
Сыктывкар (8212)25-95-17
Тамбов (4752)50-40-97
Тверь (4822)63-31-35

Тольятти (8482)63-91-07
Томск (3822)98-41-53
Тула (4872)33-79-87
Тюмень (3452)66-21-18
Улан-Удэ (3012)59-97-51
Ульяновск (8422)24-23-59
Уфа (347)229-48-12
Хабаровск (4212)92-98-04
Чебоксары (8352)28-53-07
Челябинск (351)202-03-61
Череповец (8202)49-02-64
Чита (3022)38-34-83
Якутск (4112)23-90-97
Ярославль (4852)69-52-93

Россия +7(495)268-04-70

Казахстан +7(7172)727-132

Киргизия +996(312)96-26-47

Specifications

The specifications below are for use with a 48 V DC type exclusive amplifier; for use with a 24 V DC type amplifier, see the values in parentheses.

Descriptions		Model Numbers	
		LSVG-03-4/10/20/40	LSVG-03-60
Rated Flow @ $\Delta P = 7 \text{ MPa}$ ⁽¹⁾	L/min	4, 10, 20, 40	60
Max. Operating Pressure	MPa	35	
Proof Pres. at Return Port	MPa	35	
Drain Port (Y Port) Permissible Back Pres. ⁽²⁾	MPa	0.05	
Internal Leakage (PS = 14 MPa) (Viscosity: 32 mm ² /s)	L/min	1.7 or less	
Hysteresis	%	0.1 or less	
Step Response (0 \leftrightarrow 100 %, Typical) ⁽³⁾	ms	2 (3)	3 (4)
Frequency Response (± 25 % Amplitude, Typical) ⁽³⁾	Gain: -3 dB	Hz	350 (300)
	Phase: -90°	Hz	450 (370)
Vibration Proof ⁽⁴⁾		Frequency: 10 - 60 Hz, Amplitude: 4 mm, Acceleration: 7.8 - 282 m/s ² Frequency: 61 - 2000 Hz, Amplitude: 4 - 0.0038 mm, Acceleration: 294 m/s ²	
Protection		IP 64	
Ambient Temperature	°C	-15 - +60	
Spool Type		Neutral/Zero Lap	
Spool Stroke to Stops	mm	± 0.5	± 0.75
Polarity		See the description about I/O signal characteristics on page I-19	
Linear Motor Specification	Current	A	2 [Max. 6]
	Coil Resistance	Ω	4.5 [at 20 °C]
Mass	kg	5	

Note: ⁽¹⁾ Use the valves so that the relationship between the valve pressure difference and the flow rate, as specified below in "Range of Flow Control", is met.

⁽²⁾ Back pressure at the drain port (Y) should be 0.05 MPa or less and not be a negative pressure.

⁽³⁾ This value is measured for each valve; it may vary depending on the actual circuit.

⁽⁴⁾ There are restrictions on the mounting position; refer to the instructions for details.

Range of Flow Control

● Control Method: 4-Way Valve

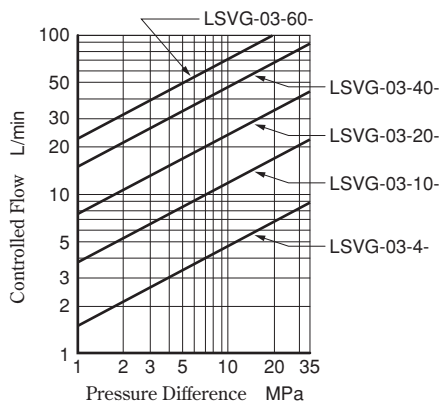
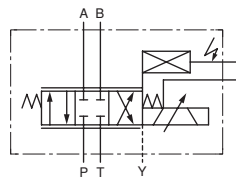

● Control Method: 3-Way Valve

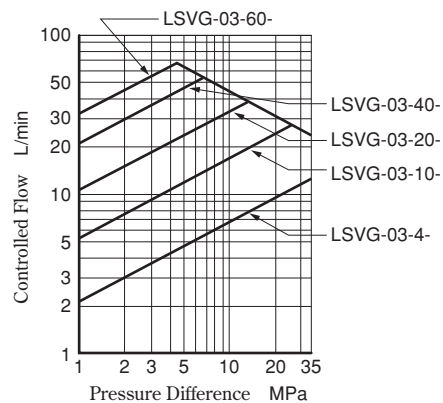
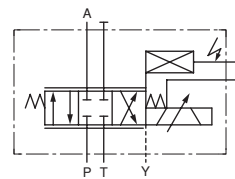

LSVG-03

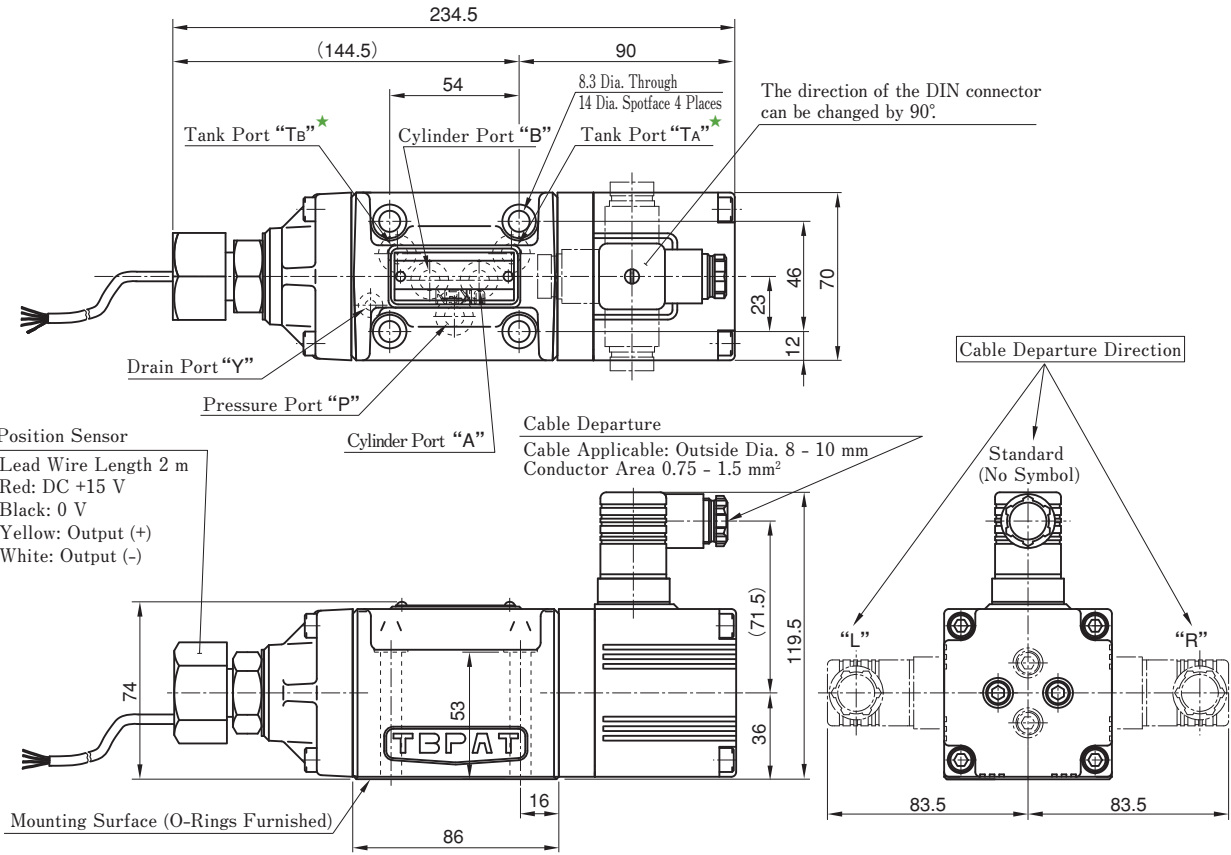

Note) Refer to the wiring diagram on page I-21 for detailed connection between the DIN connector/position sensor and the amplifier.

● O-Rings for the Ports

Port	O-Ring Size	Qty.
P, A, B, T	AS568-014 (NBR-90)	5
Y	OR NBR-90 P7-N	1

O-rings made of fluorinated rubber are required to use phosphate ester type fluids.

[Mounting Surface]

Prepare a mounting surface shown on the right. Basically, the dimensions of the mounting surface conform to the ISO standard, but the specifications for valve mounting screws are different as follows.

Consult us for valves available with M6 mounting screws.

	ISO 4401-05-04-0-94	Mounting Surface for LSVG-03
Valve Mounting Screw	M6	M8

The mounting surface should have a good machined finish. (▽)

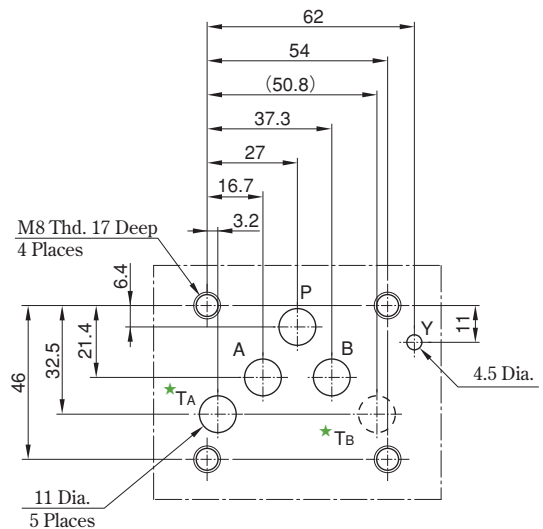

★ There are two tank ports "TA" and "TB" ; however, "TA" may be used alone.

Characteristics of LSVG-03-4/10/20/40/60 (Fluid Viscosity: 30 mm²/s)

No-Load Flow Characteristics

<Conditions>

● Valve Pressure Difference : 7 MPa

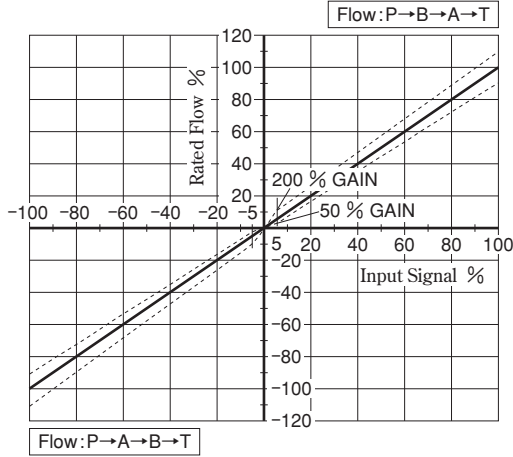

Load Flow Characteristics

<Conditions>

● Input Signal : 100 %

Note) Tolerance for Load Flow : ±10 %

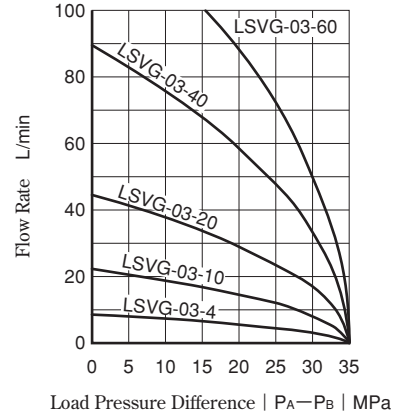

Step Response

<Conditions>

● Input Amplitude : 0 ⇔ 100 % ● Supply Pressure : 14 MPa

● LSVG-03-4/10/20/40-10

Amplifier : AMLS-A-D48- * -10 (Power Supply: 48 V DC)

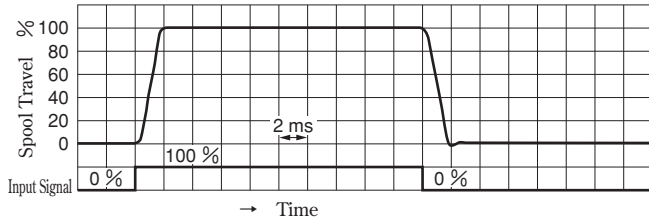

● LSVG-03-60-10

Amplifier : AMLS-B-D48- * -10 (Power Supply: 48 V DC)

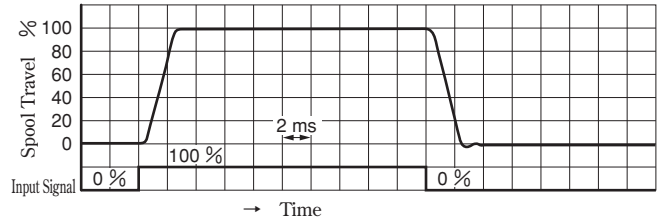

Amplifier : AMLS-A-D24- * -10 (Power Supply: 24 V DC)

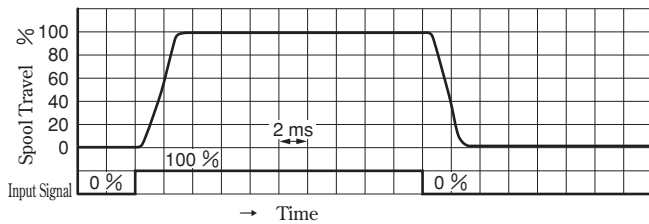

Amplifier : AMLS-B-D24- * -10 (Power Supply: 24 V DC)

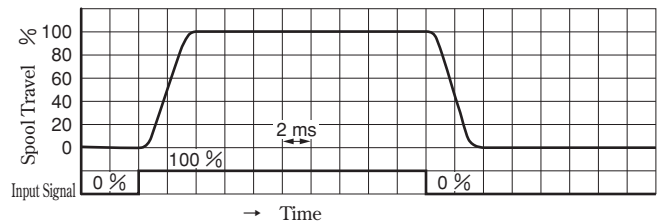

Frequency Response

<Conditions>

● Hydraulic Circuit: Port A/B Closed ● Supply Pressure : 14 MPa

● LSVG-03-4/10/20/40-10

Amplifier : AMLS-A-D48- * -10 (Power Supply: 48 V DC)
Input Signal $\pm 25\%$

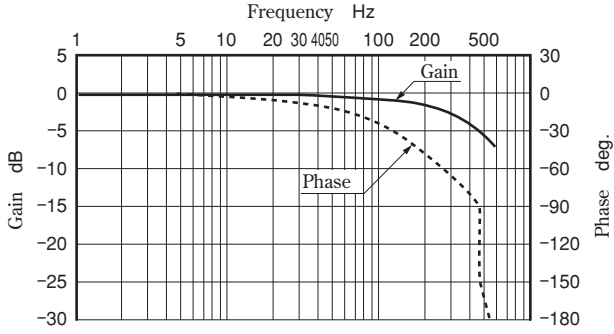

Input Signal $\pm 100\%$

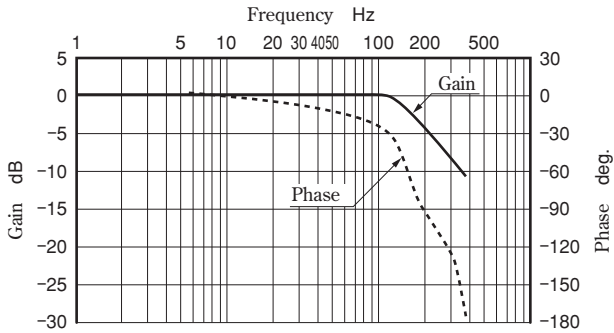

Amplifier : AMLS-A-D24- * -10 (Power Supply: 24 V DC)
Input Signal $\pm 25\%$

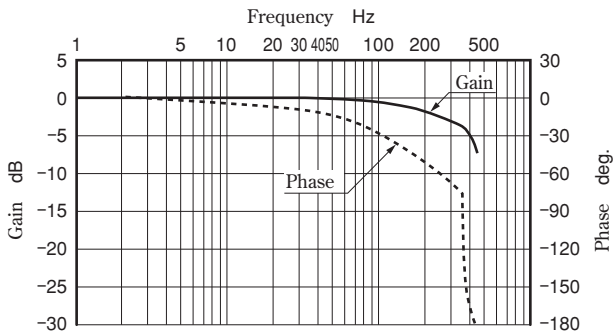

Input Signal $\pm 100\%$

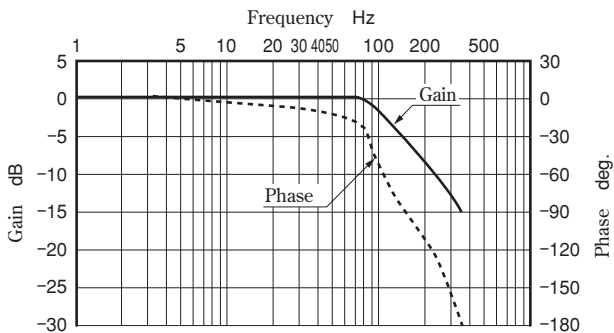

● LSVG-03-60-10

Amplifier : AMLS-B-D48- * -10 (Power Supply: 48 V DC)
Input Signal $\pm 25\%$

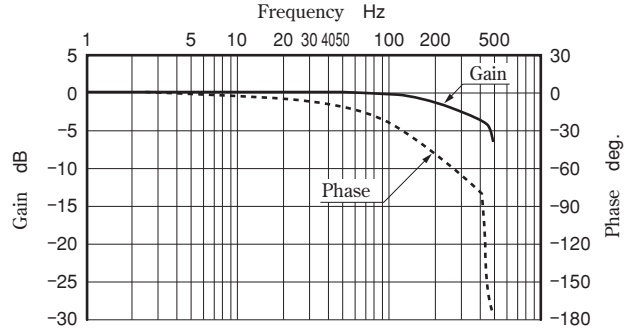

Input Signal $\pm 100\%$

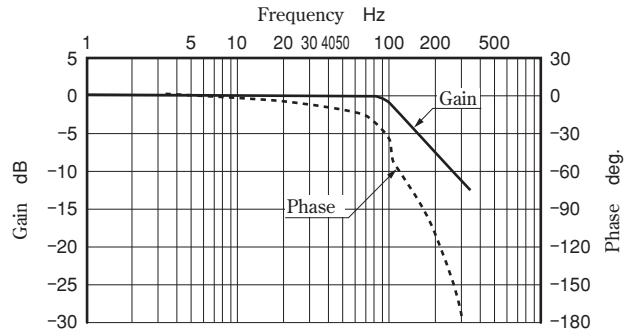

Amplifier : AMLS-B-D24- * -10 (Power Supply: 24 V DC)
Input Signal $\pm 25\%$

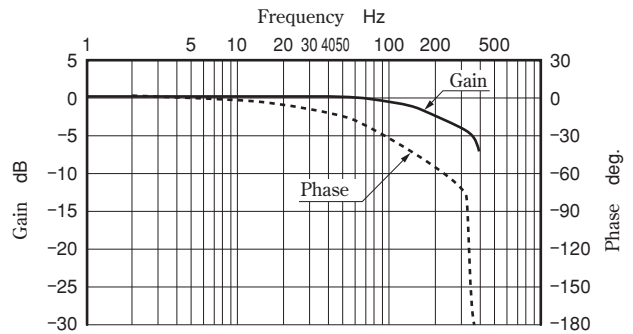

Input Signal $\pm 100\%$

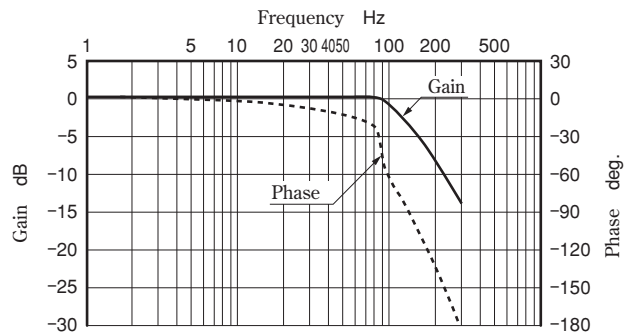

Tow Stage Type High-Speed Linear Servo Valves

Two stage type linear servo valves are a type of high-flow servo valve that has a direct type high speed linear servo valve in its pilot stage to drive the main spool. These valves control the positions of the pilot and main spools with electrical feedback, achieving high accuracy and response.

- **High flow**
The valves consist of two stages to provide a high flow rate (Rated flow at $\Delta P = 7$ MPa: 750 - 3800 L/min).
- **High accuracy**
The valves have a low hysteresis of 0.1 % or less, achieving high accuracy. They allow the main unit to operate with much higher repeatability.
- **High response characteristics**
The valves provide significantly high levels of step and frequency responses, which are typically used as measures of response characteristics; the step response is 8 ms (0 \leftrightarrow 100 %), and the frequency response is 105 Hz/90° (± 25 % amplitude) (Representative values for LSVHG-06-900). Thus, the valves ensure the achievement of unprecedented high response.
- **Excellent contamination resistance**
As is the case with the direct type linear servo valves, the permissible level of fluid contamination for these valves is up to NAS 1638 class 10.

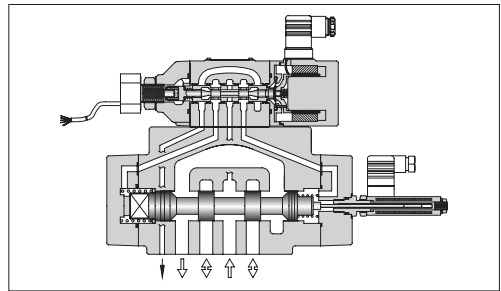
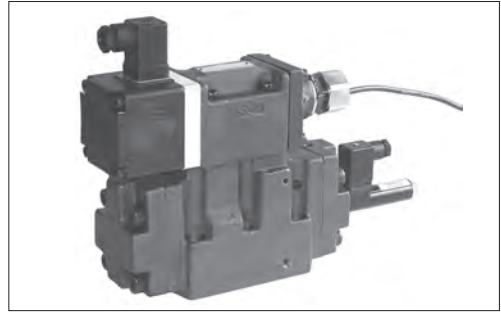

Graphic Symbols

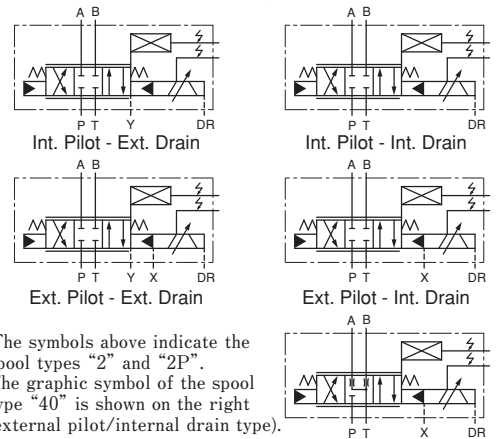

Note) The symbols above indicate the spool types "2" and "2P". The graphic symbol of the spool type "40" is shown on the right (external pilot/internal drain type).

Model Number Designation

F	LSVHG	-06	-900	-2P	-E	T	-R	-A	-10
Fluid Type	Series Number	Valve Size	Rated Flow @ $\Delta P = 7$ MPa	Spool Type	Pilot Connection	Drain Connection	Cable Departure Direction	Fail-safe Function	Design Number
F : Special Seals for Phosphate Ester Type Fluid (Omit if not required)	LSVHG : Two Stage Type High Speed Linear Servo Valves	04	750 : 750 L/min	2 : 10% Overlap 	None : Internal Pilot E : External Pilot	None : External Drain T : Internal Drain	(Viewed from the linear motor side) None : Upper (Standard) R : Right L : Left	None : P→B→A→T Position Valve Opening: Full A : P→A→B→T Position Valve Opening: Full	10
		06	900 : 900 L/min 1300 : 1300 L/min	40 : Open Center A, B & T 					20
		10	3800 : 3800 L/min	2P : Zero Lap (Dual Flow Gain)					

Exclusive Amplifiers

To ensure stable performance, it is recommended to use Yuken's AMLS series linear servo amplifiers.

Valve Model Numbers	Amplifier Model
LSVHG-04-750	AMLS-C2-D * - * -10
LSVHG-06-900	AMLS-C-D * - * -10
LSVHG-06-1300 LSVHG-10-3800	AMLS-D-D * - * -10

Accessories

Model Numbers	Mounting Bolt	Qty.	Bolt Tightening Torque
LSVHG-04	Hex. Soc. Head Cap Screw:M 6 ×55L	2	12.9 - 15.9 Nm
	Hex. Soc. Head Cap Screw:M10×60L	4	60.6 - 74.1 Nm
LSVHG-06	Hex. Soc. Head Cap Screw:M12×85L	6	104 - 127 Nm
LSVHG-10	Hex. Soc. Head Cap Screw:M20×90L	6	494 - 603 Nm

Specifications

The specifications below are for use with a 48 V DC type exclusive amplifier; for use with a 24 V DC type amplifier, see the values in parentheses.

Descriptions		Model Numbers		LSVHG-04-750			LSVHG-06-900			LSVHG-06-1300			LSVHG-10-3800		
Rated Flow @ $\Delta P = 7$ MPa (4-Way Valve)		L/min	750			900			1300			3800			
Rated Flow @ $\Delta P' = 0.5$ MPa (per Land)		L/min	283			340			490			1440			
Max. Operating Pressure		MPa	35			35			31.5			35			
Proof Pres. at Return Port	External Drain	MPa	31.5			35			25			28			
	Internal Drain ⁽¹⁾	MPa	31.5			35			25			28			
DR Port Permissible Back Pressure ⁽²⁾		MPa	0.05												
Pilot Pressure ⁽³⁾		MPa	1.5 - 35									1.5 - 25			
Pilot Flow Rate ⁽⁴⁾		L/min	27 (22) or more			30 (24) or more			34 (27) or more			32 (27) or more			
Pilot Valve Max. Leakage		Ps=Pp=14 MPa 32 mm ² /s	L/min												
Main Valve Max. Leakage		Spool Type	-2-	-40-	-2P-	-2-	-40-	-2P-	-2-	-40-	-2P-	-2-	-40-	-2P-	
		Ps=Pp=14 MPa 32 mm ² /s	L/min	0.8	1.6	6.8	0.9	1.8	7	1	2	8	3	6	10
Hysteresis		%	0.1 or less												
Step Response (0 <=> 100 %, Typical) ⁽⁵⁾		ms	8 (10)			8 (10)			10 (13)			15 (18)			
Frequency Response (± 25 % Amplitude, Typical) ⁽⁵⁾	Gain: -3 dB	Hz	150 (140)			160 (130)			150 (110)			100 (60)			
	Phase: -90°	Hz	110 (100)			105 (100)			100 (100)			85 (75)			
Vibration Proof ⁽⁶⁾		Frequency: 10 - 60 Hz, Amplitude: 4 mm, Acceleration: 7.8 - 282 m/s ² Frequency: 61 - 2000 Hz, Amplitude: 4 - 0.0038 mm, Acceleration: 294 m/s ²													
Protection		IP 64													
Ambient Temperature		°C	-15 - +60												
Spool Stroke to Stops		mm	± 5			± 5			± 7			± 7			
Spool End Area		cm ²	7.1			8			8			11.3			
Polarity		See the description about I/O signal characteristics on page I-19													
Linear Motor Specification	Current	A	2 [Max. 6]												
	Coil Resistance	Ω	4.5												
Approx. Mass		kg	12			20			21			78			

Note) ⁽¹⁾ Pressure at the return port should be at actual supply pressure or less.

⁽²⁾ Back pressure at the drain port should be 0.05 MPa or less and not be a negative pressure.

⁽³⁾ Supply pressure for the pilot valve should be 1.5 to 35 MPa (1.5 to 25 MPa for LSVHG-10) and should also be 60 % of actual supply pressure or more.

⁽⁴⁾ The pilot flow is calculated based on a pilot pressure of 14 MPa and the above step response.

⁽⁵⁾ This value is measured for each valve based on a pilot pressure of 14 MPa; it may vary depending on the actual circuit/operation conditions.

⁽⁶⁾ There are restrictions on the mounting position; refer to the instructions for details.

LSVHG-04

The direction of the DIN connector can be changed by 90°.

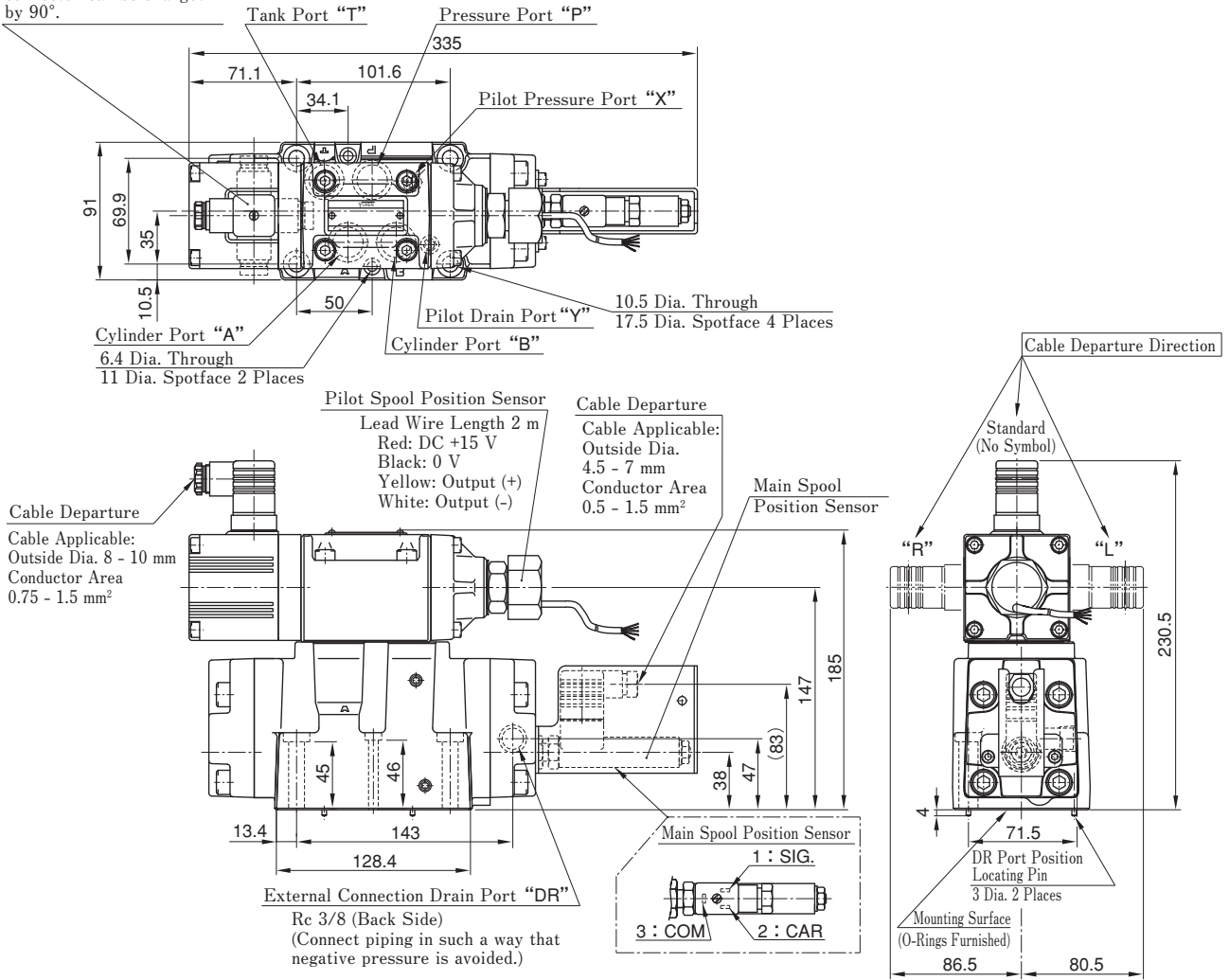

Note) Refer to the wiring diagram on page I-21 for detailed connection between the pilot valve DIN connector/position sensors (pilot and main spools) and the amplifier.

[Mounting Surface]

Prepare a mounting surface shown on the right. Basically, the dimensions of the mounting surface conform to the ISO standard, but the specifications for the ports P, A, B, and T are different as follows.

	ISO 4401-07-07-0-05	Mounting Surface for LSVHG-04
Dia. of Port P, A, B, T	17.5 Dia.	20 Dia.

The mounting surface should have a good machined finish. (▽)

● O-Rings for the Ports

Port	O-Ring Size	Qty.
P, A, B, T	OR NBR-90 P22-N	4
X, Y	AS568-012 (NBR-90)	2

O-rings made of fluorinated rubber are required to use phosphate ester type fluids.

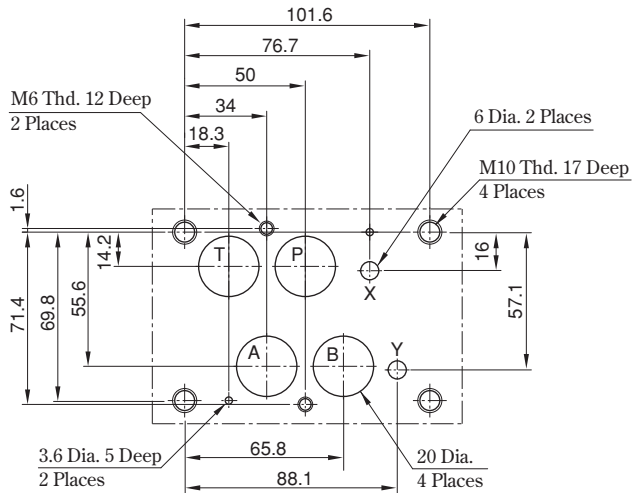

LSVHG-06

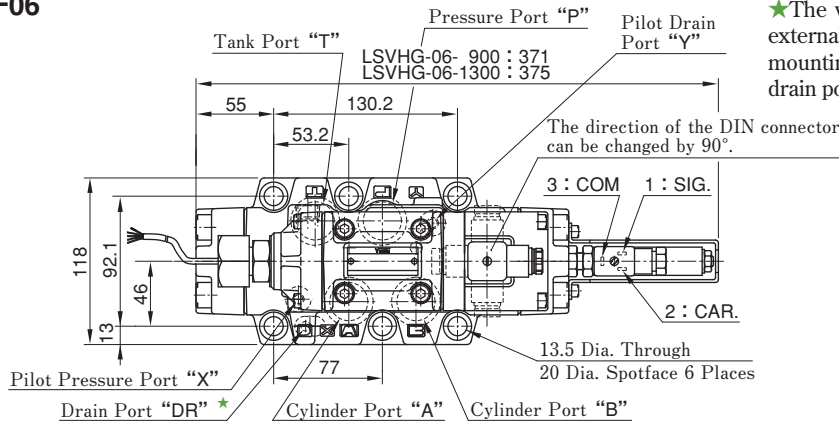

★The valve has two "DR" ports: one for external connection and the other on the mounting surface. Use either one of the drain ports.

Pilot Spool Position Sensor

- Lead Wire Length 2 m
- Red: DC +15 V
- Black: 0 V
- Yellow: Output (+)
- White: Output (-)

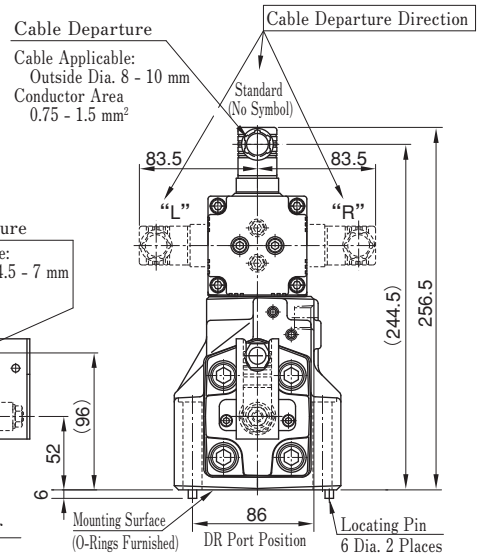
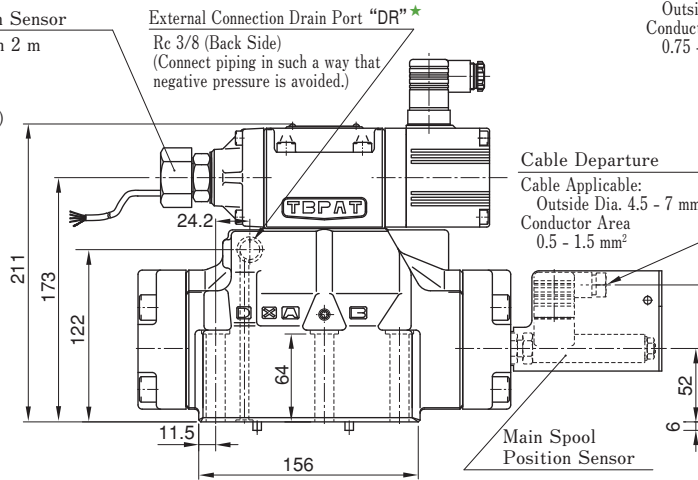

Note) Refer to the wiring diagram on page I-21 for detailed connection between the pilot valve DIN connector/position sensors (pilot and main spools) and the amplifier.

【Mounting Surface】

Prepare a mounting surface shown on the right. Basically, the dimensions of the mounting surface conform to the ISO standard, but the specifications for the ports P, A, B, and T are different as follows.

	ISO 4401-08-08-0-05	Mounting Surface for LSVHG-06-900	Mounting Surface for LSVHG-06-1300
Dia. of Port P, A, B, T	23.4 Dia.	27 Dia.	32 Dia.
Drain Port	None	Available (6 Dia.)	

The mounting surface should have a good machined finish. ($\sqrt{6}$)

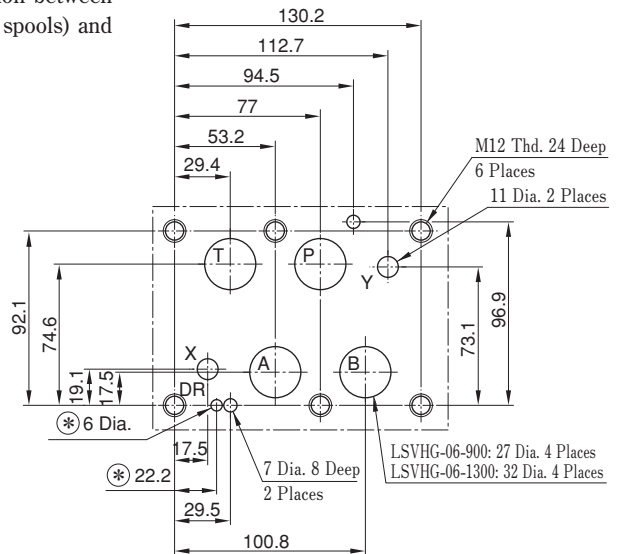

Note) ⊗: Not required if the external connection drain port is used.

● O-Rings for the Ports

Port	O-Ring Size		Qty.
	LSVHG-06-900	LSVHG-06-1300	
P, A, B, T	AS568-123 (NBR-90)	AS568-126 (NBR-90)	4
X, Y	OR NBR-90 P14-N		2
DR	AS568-016 (NBR-90)		1

O-rings made of fluorinated rubber are required to use phosphate ester type fluids.

LSVHG-10

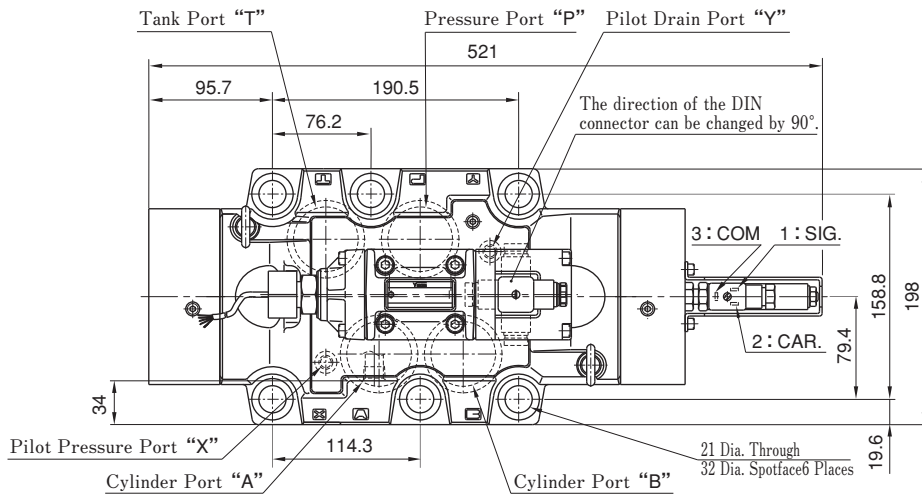

Pilot Spool Position Sensor

- Lead Wire Length 2 m
- Red: DC +15 V
- Black: 0 V
- Yellow: Output (+)
- White: Output (-)

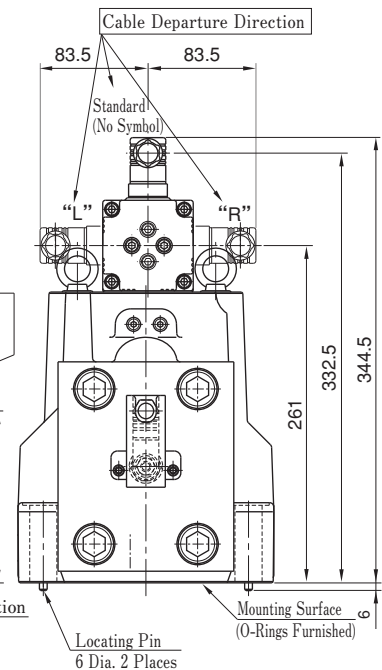
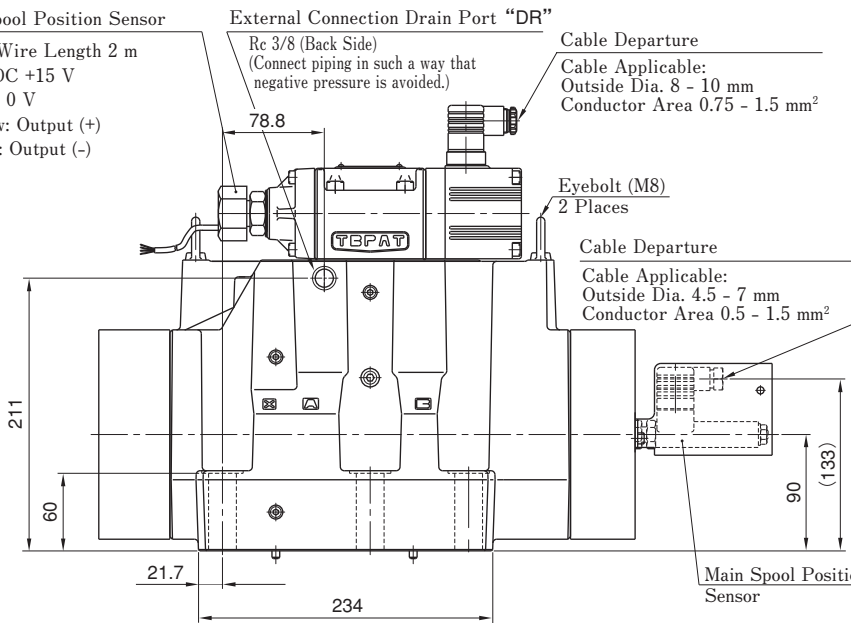

Note) Refer to the wiring diagram on page I-21 for detailed connection between the pilot valve DIN connector/ position sensors (pilot and main spools) and the amplifier.

[Mounting Surface]

Prepare a mounting surface shown on the right. Basically, the dimensions of the mounting surface conform to the ISO standard, but the specifications for the ports P, A, B, and T are different as follows.

	ISO 4401-08-09-0-05	Mounting Surface for LSVHG-10
Dia. of Port P, A, B, T	36 Dia.	50 Dia.

The mounting surface should have a good machined finish. ($\frac{1}{16}$)

● O-Rings for the Ports

Port	O-Ring Size	Qty.
P, A, B, T	AS568-227 (NBR-90)	4
X, Y	AS568-015 (NBR-90)	2

O-rings made of fluorinated rubber are required to use phosphate ester type fluids.

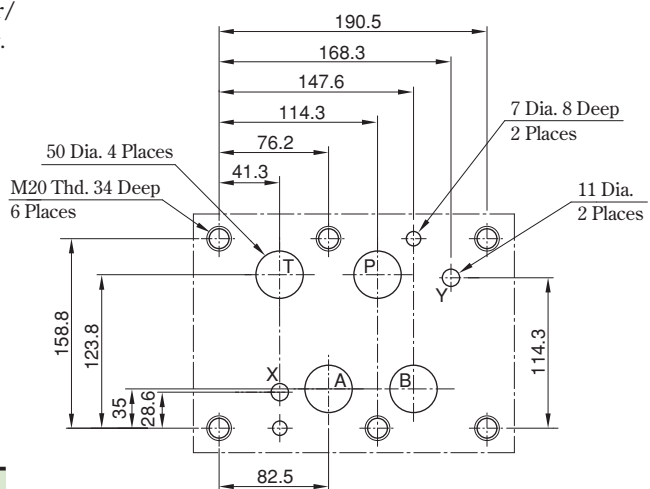

Characteristics of LSVHG-04-750 (Fluid Viscosity: 30 mm²/s)

No-Load Flow Characteristics

<Conditions> ● Valve Pressure Difference : 1 MPa (Pressure Difference per Land : 0.5 MPa)

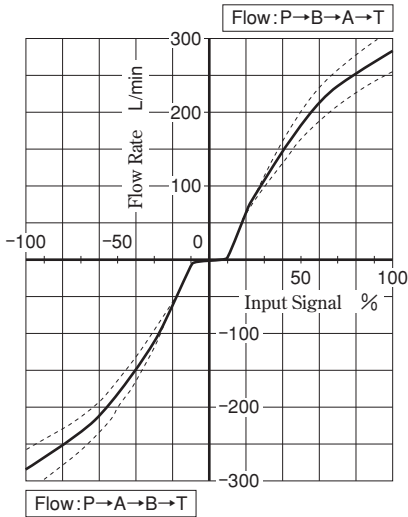

Around Null Position Input Signal -20 ↔ +20 %

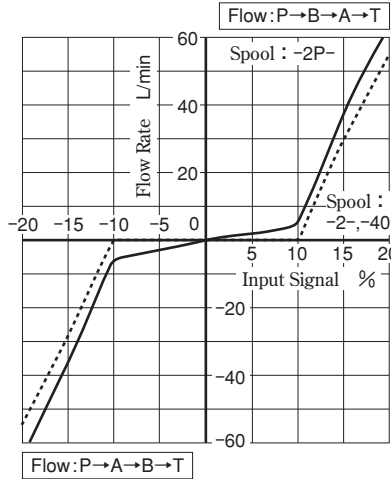

Load Flow Characteristics

<Conditions>

● Input Signal : 100 %

Note) Tolerance for Load Flow

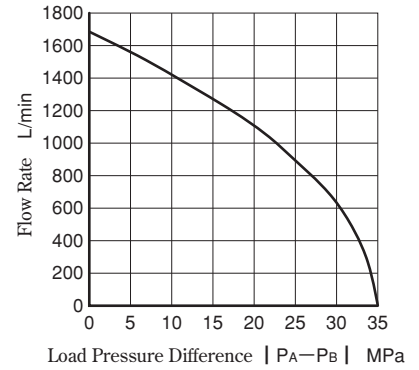

Step Response

<Conditions> ● Input Signal : 0 ↔ 100 % ● Supply/Pilot Pressure : 14 MPa

Amplifier: AMLS-C2-D48-* -10 (Power Supply: 48 V DC)

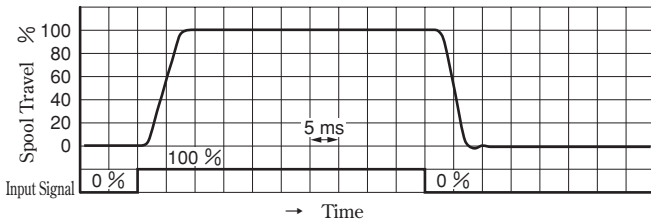

Amplifier: AMLS-C2-D24-* -10 (Power Supply: 24 V DC)

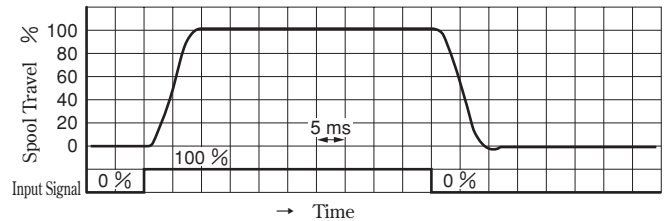

Frequency Response

<Conditions> ● Hydraulic Circuit: Port A/B Closed ● Supply/Pilot Pressure : 14 MPa

Amplifier: AMLS-C2-D48-* -10 (Power Supply: 48 V DC)

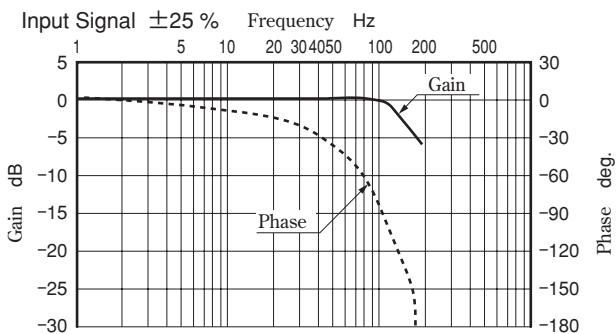

Amplifier: AMLS-C2-D24-* -10 (Power Supply: 24 V DC)

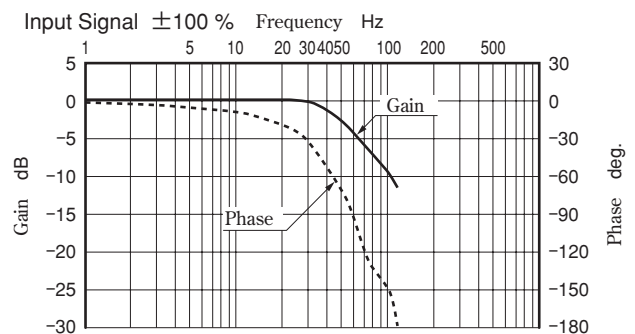
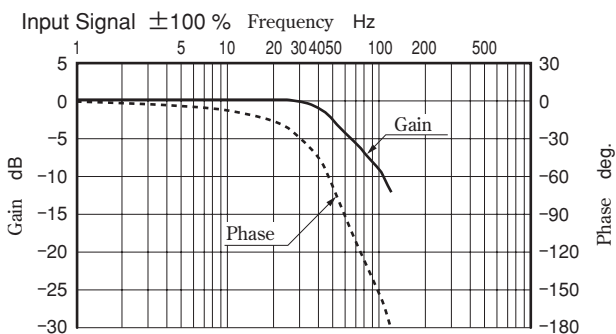
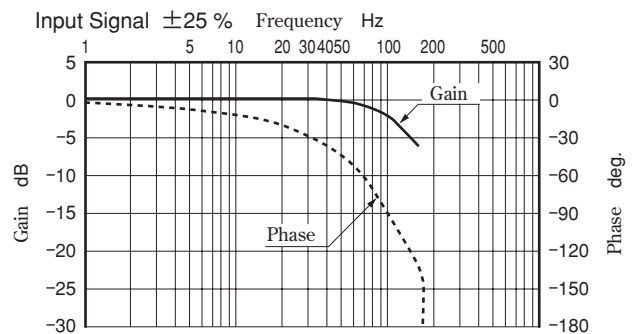

Characteristics of LSVHG-06-900 (Fluid Viscosity: 30 mm²/s)

No-Load Flow Characteristics

<Conditions> ● Valve Pressure Difference : 1 MPa (Pressure Difference per Land : 0.5 MPa)

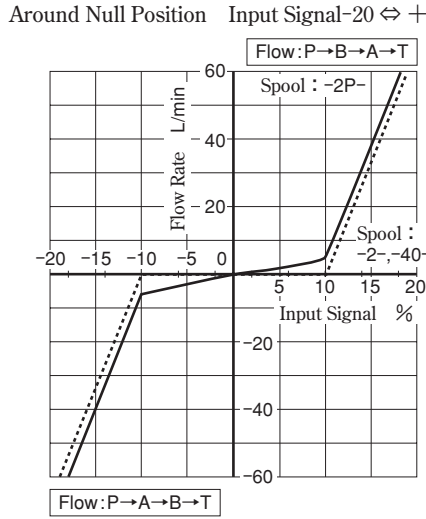
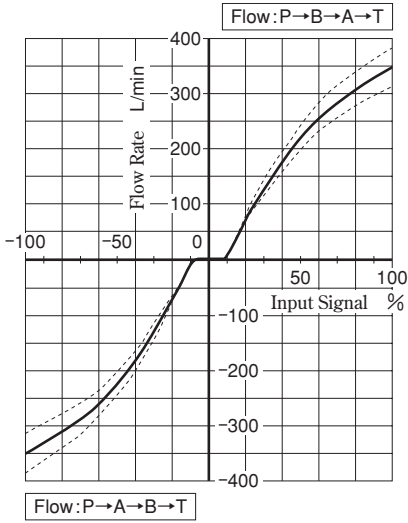

Load Flow Characteristics

<Conditions>

● Input Signal : 100 %

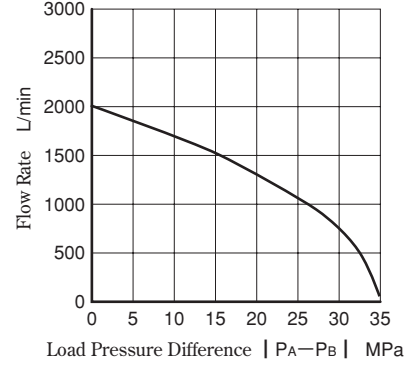

Step Response

<Conditions> ● Input Signal : 0 ⇔ 100 % ● Supply/Pilot Pressure : 14 MPa

Amplifier : AMLS-C-D48- *-10 (Power Supply: 48 V DC)

Amplifier: AMLS-C-D24- *-10 (Power Supply: 24 V DC)

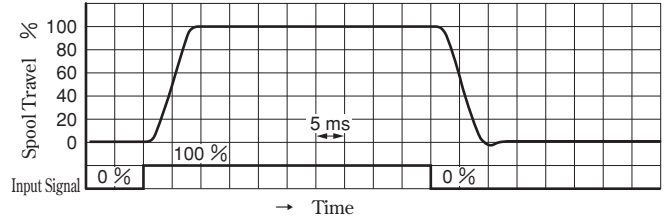
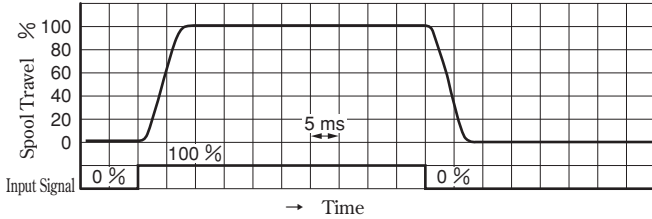

Frequency Response

<Conditions> ● Hydraulic Circuit: Port A/B Closed ● Supply/Pilot Pressure : 14 MPa

Amplifier : AMLS-C-D48- *-10 (Power Supply: 48 V DC)

Amplifier : AMLS-C-D24- *-10 (Power Supply: 24 V DC)

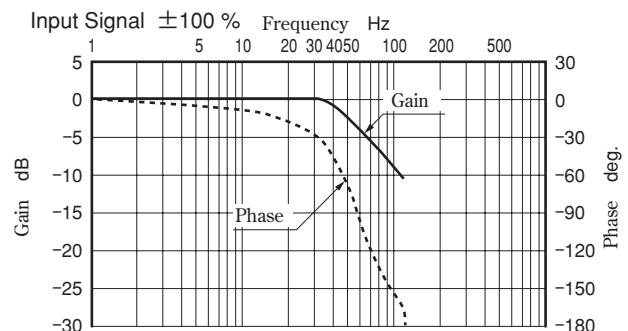
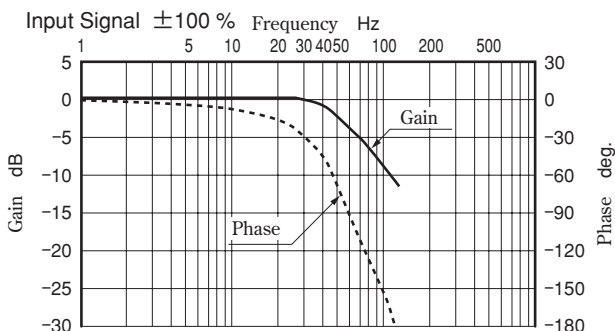
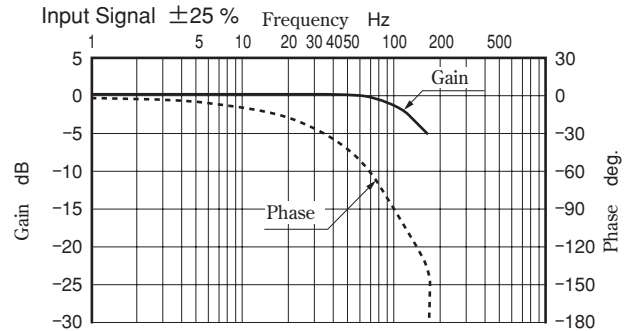
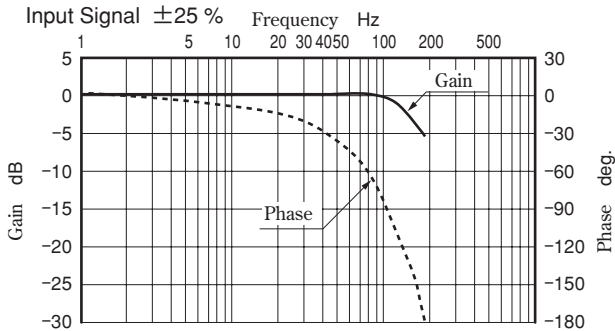

Characteristics of LSVHG-06-1300 (Fluid Viscosity: 30 mm²/s)

No-Load Flow Characteristics

<Conditions> ● Valve Pressure Difference: 1 MPa (Pressure Difference per Land : 0.5 MPa)

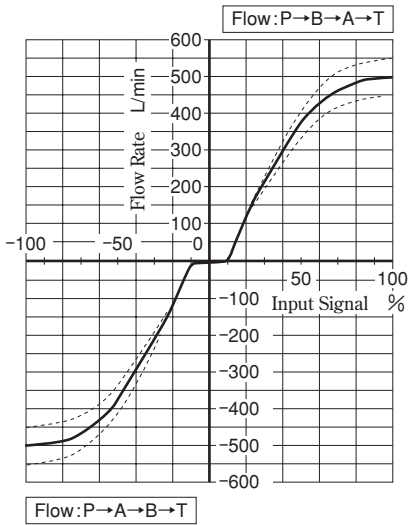

Around Null Position Input Signal -20 ⇔ +20 %

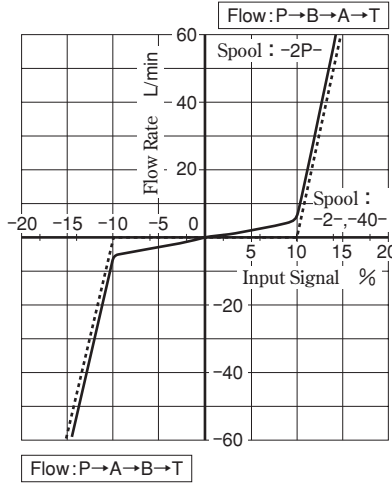

Load Flow Characteristics

<Conditions>

● Input Signal : 100 %

Note) Tolerance for Load Flow : ±10 %

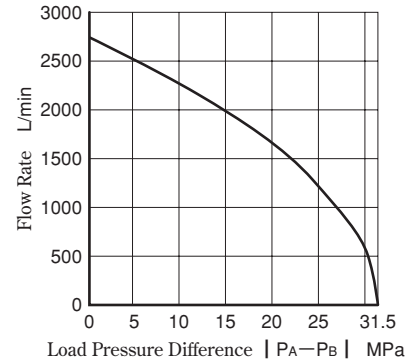

Step Response

<Conditions> ● Input Signal : 0 ⇔ 100 % ● Supply/Pilot Pressure : 14 MPa

Amplifier : AMLS-D-D48-* -10 (Power Supply: 48 V DC)

Amplifier : AMLS-D-D24-* -10 (Power Supply: 24 V DC)

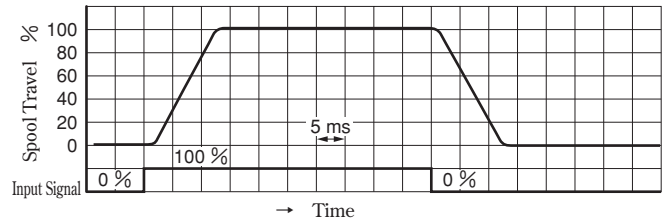
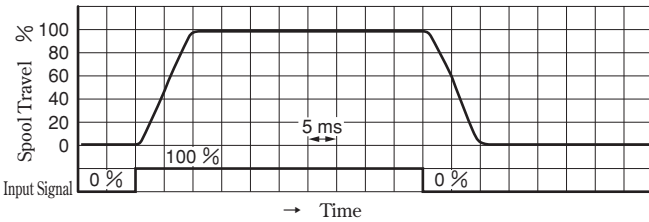

Frequency Response

<Conditions> ● Hydraulic Circuit: Port A/B Closed ● Supply/Pilot Pressure : 14 MPa

Amplifier : AMLS-D-D48-* -10 (Power Supply: 48 V DC)

Amplifier : AMLS-D-D24-* -10 (Power Supply: 24 V DC)

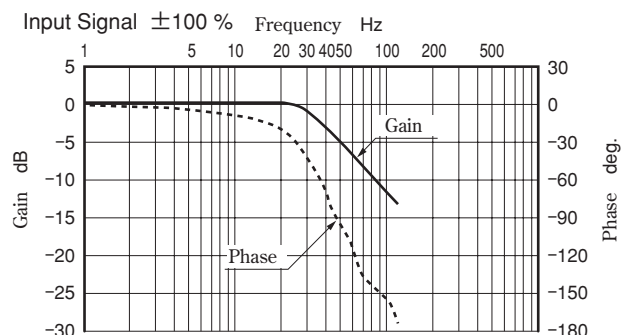
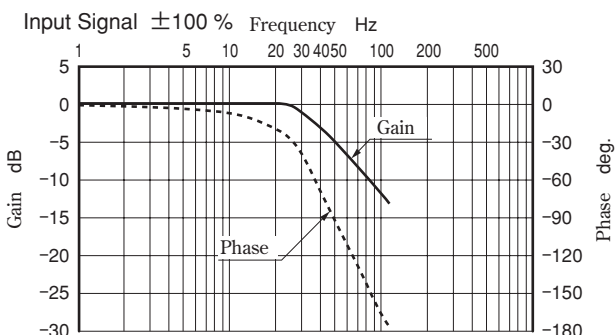
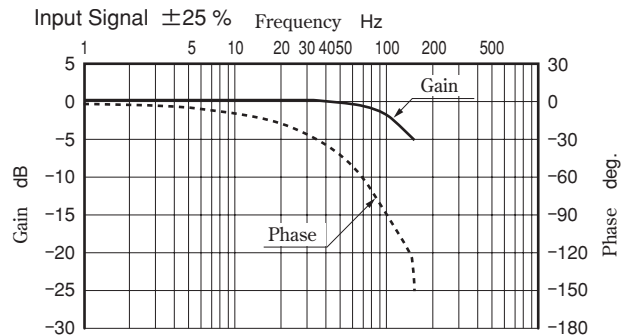
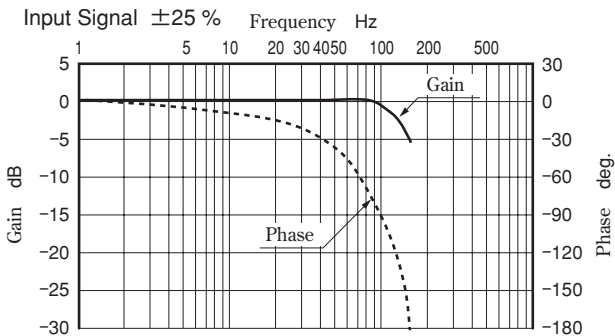

Characteristics of LSVHG-10-3800 (Fluid Viscosity: 30 mm²/s)

No-Load Flow Characteristics

<Conditions> ● Valve Pressure Difference : 1 MPa (Pressure Difference per Land : 0.5 MPa)

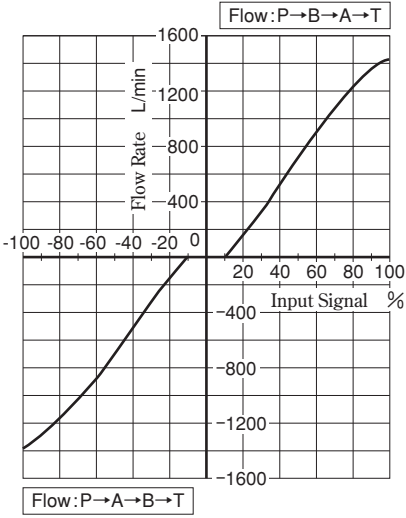

Around Null Position Input Signal -20 ⇔ +20 %

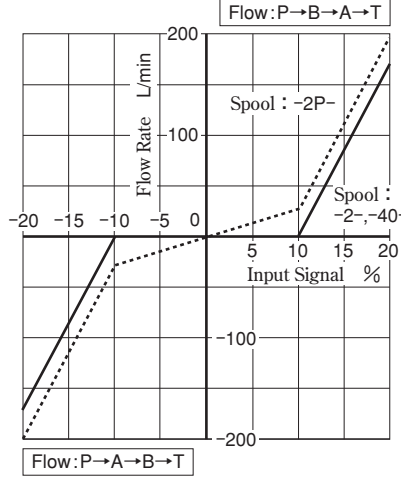

Flow: P→A→B→T

Load Flow Characteristics

<Conditions>

● Input Signal : 100 %

Note) Tolerance for Load Flow : ±10 %

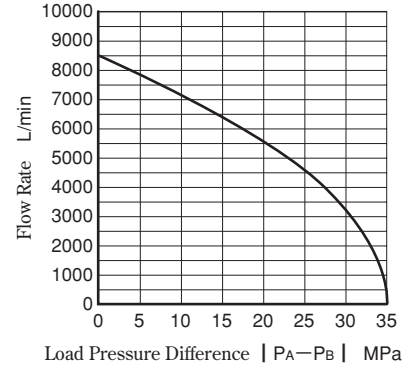

Step Response

<Conditions> ● Input Signal : 0 ⇔ 100 % ● Supply/Pilot Pressure : 14 MPa

Amplifier: AMLS-D-D48 * -10 (Power Supply: 48 V DC)

Amplifier: AMLS-D-D24 * -10 (Power Supply: 24 V DC)

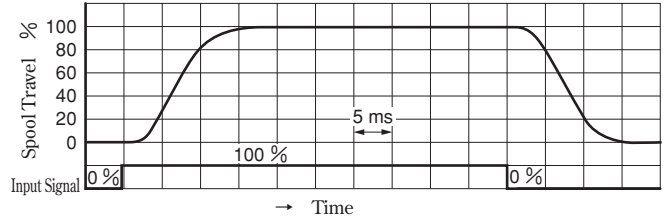
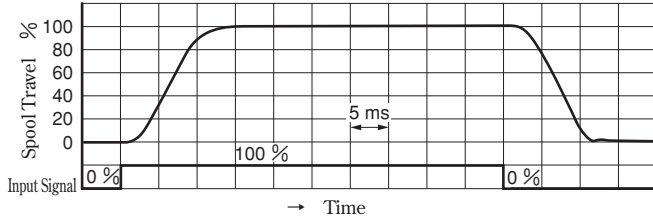

Frequency Response

<Conditions> ● Hydraulic Circuit: Port A/B Closed ● Supply/Pilot Pressure : 14 MPa

Amplifier: AMLS-D-D48 * -10 (Power Supply: 48 V DC)

Amplifier: AMLS-D-D24 * -10 (Power Supply: 24 V DC)

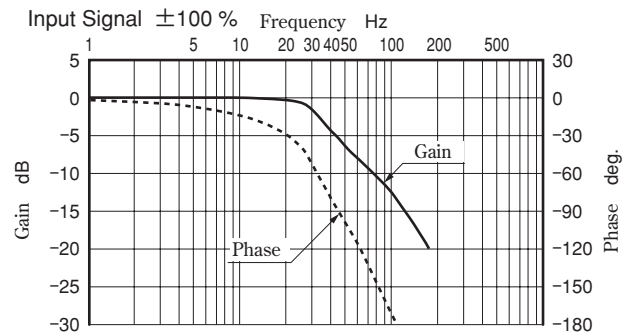
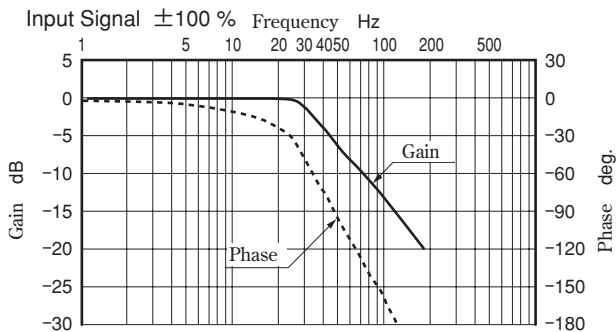
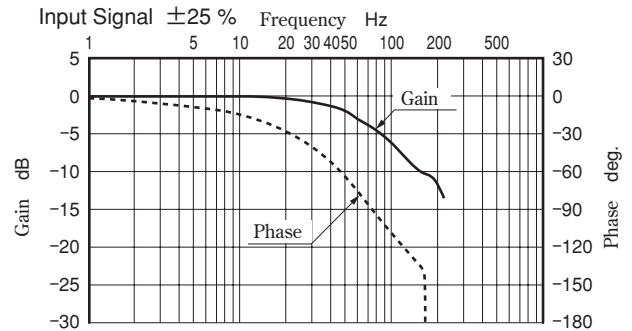
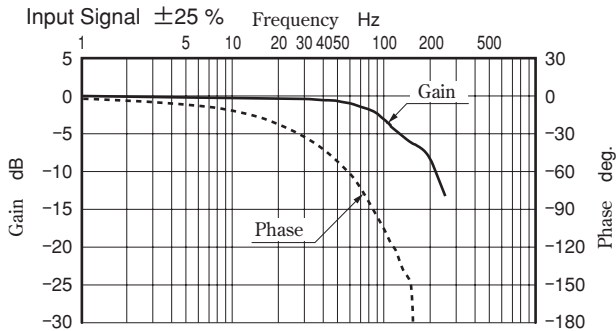

Linear Servo Amplifier

This amplifier is used to drive LSVG/LSVHG series high speed linear servo valves. With an optimal design for the servo valves, the amplifier can maximize the valve performance.

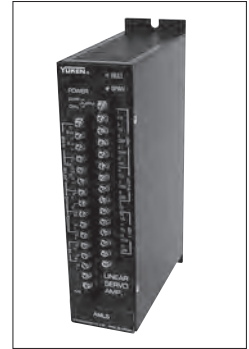

Specifications

Model Numbers	AMLS- *-D48- *-10	AMLS- *-D24- *-10
Descriptions		
Power Supply	48 V \pm 2.4 V DC (200 VA or more)	24 V \pm 1.2 V DC (100 VA or more)
Rated Output Current	Continuous \pm 2 A (4 A Peak)	Continuous \pm 2 A (3 A Peak)
Input/Output Signal	Output Signal = Spool Travel Monitoring A1 : Voltage Signal \pm 10 V ($R_i = 100 \text{ k}\Omega$, $R_L \geq 10 \text{ k}\Omega$) B1 : Current Signal 4 - 20 mA ($R_i = 200 \Omega$, $R_L = 100 - 500 \Omega$) C1 : Current Signal \pm 10 mA ($R_i = 200 \Omega$, $R_L = 100 - 500 \Omega$)	
Control Input /Output Signal	a) Servo "ON" Input/Alarm Reset Input: Photocoupler Input Voltage: +15 V DC to +28 V DC, Input Impedance: 2.2 k Ω b) Overcurrent Output (CURR.AL.)/Deviation Alarm Output (CRTL.AL.): Photocoupler Output Voltage: Max. 50 V DC, Current: Max. 30 mA	
Ambient Temperature $^{\circ}\text{C}$	0 - +50	
Ambient Humidity	20 - 90 %Rh (No Condensation)	
Mass kg	1.8	

Model Number Designation

AMLS	-A	-D48	-A1	-10
Series Number	Applicable Valve Type	Supply Voltage	Input Signal/ Spool Travel Monitoring	Design Number
AMLS : Linear Servo Amplifier	A : LSVG-03-4/10/20/40 B : LSVG-03-60 C : LSVHG-06-900 C2 : LSVHG-04 D : LSVHG-06-1300 LSVHG-10-3800	D48 : DC 48 V D24 : DC 24 V	A1: Voltage Signal \pm 10 V B1: Current Signal 4 - 20 mA C1: Current Signal \pm 10 mA	10

I/O Signal Characteristics

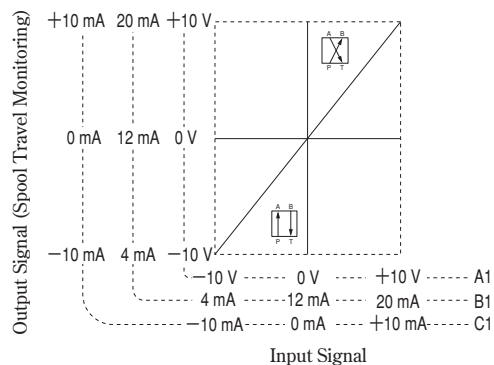

Appearance/Terminal Names

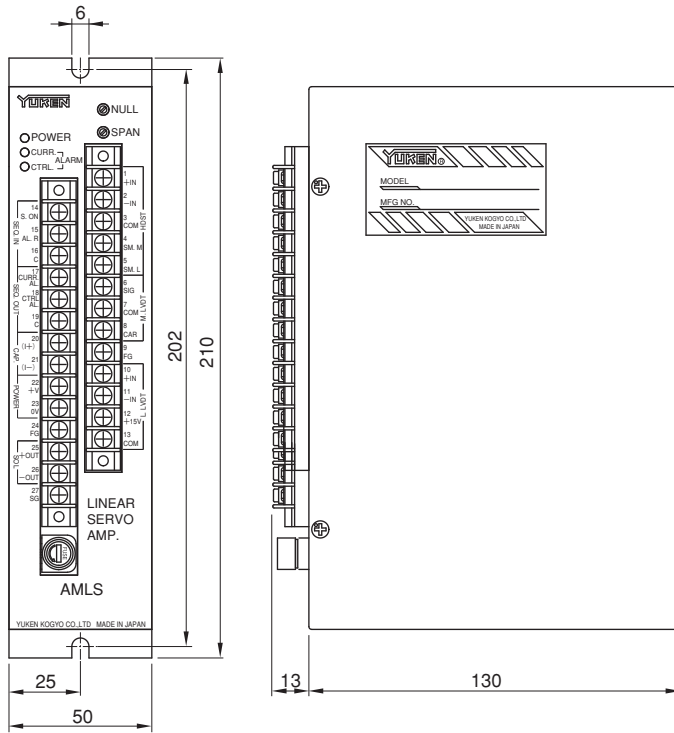

● Terminal Name

No.	Terminal Name	
1	Input Signal	+IN
2		-IN
3	Common	COM
4	Sensor	Main Valve Spool
5	Monitoring	Pilot Valve/Direct Type Linear Servo Valve
6		SIG
7	Main Valve Spool Travel Sensor	COM
8		CAR
9	Frame Grounding	FG
10		+IN
11	Spool Travel Sensor for Pilot Valve/Direct Type Linear Servo Valve	-IN
12		+15V
13		COM
14	Sequence	Servo ON
15	Input	Alarm Reset
16		Input Common
17	Sequence	Overcurrent Alarm
18	Output	Deviation Alarm
19		Output Common
20	Capacitor Connection Terminal	Cap.(+)
21		Cap.(-)
22	Power Supply	+V
23		0V
24	Frame Grounding	FG
25	SOL Output	+OUT
26		-OUT
27	Signal Grounding	SG

Block Diagram

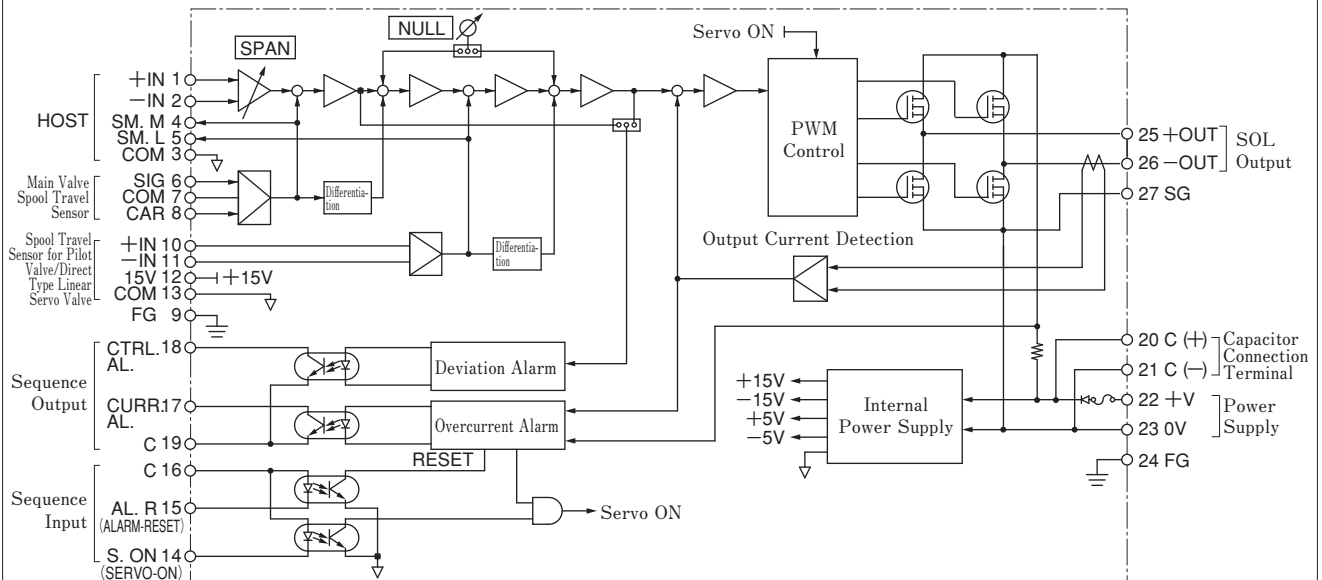

● AMLS-A, AMLS-B

* To hold the valve spool at the neutral position for a few seconds upon power failure or after power-off, connect the capacitor between C (+) and C (-) (terminal blocks 20 and 21).

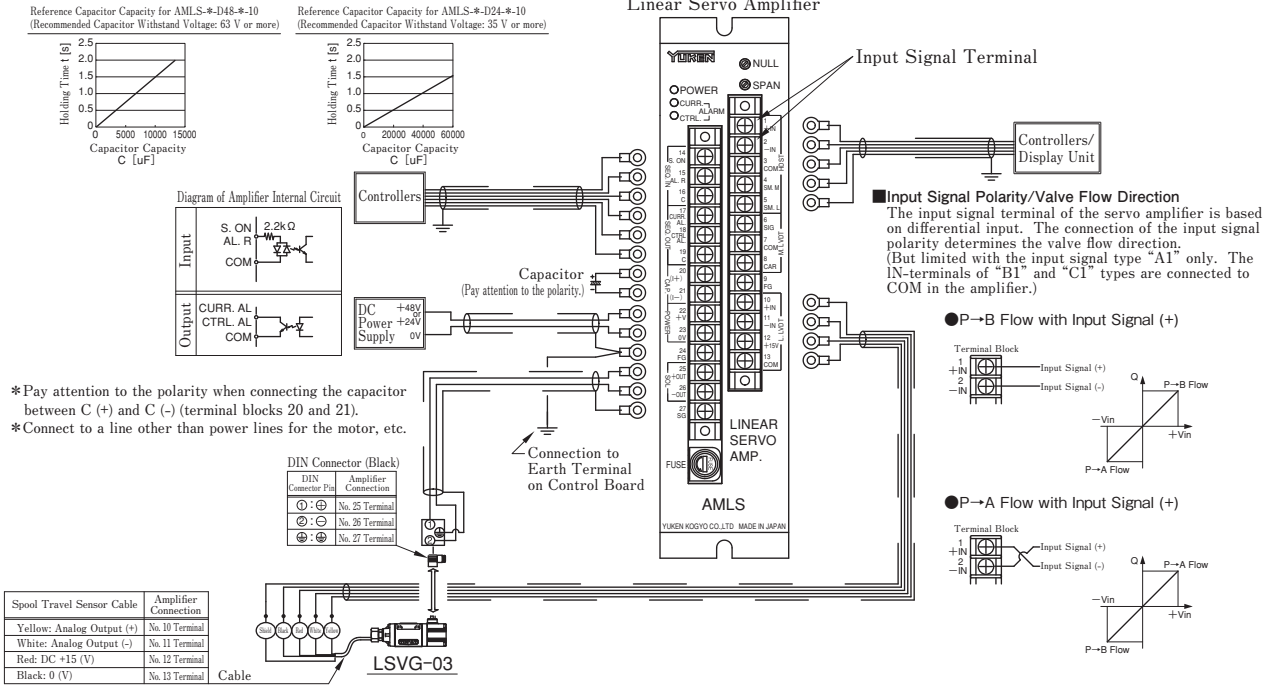

● AMLS-C, AMLS-C2, AMLS-D

* To hold the valve spool at the neutral position for a few seconds upon power failure or after power-off, connect the capacitor between C (+) and C (-) (terminal blocks 20 and 21).

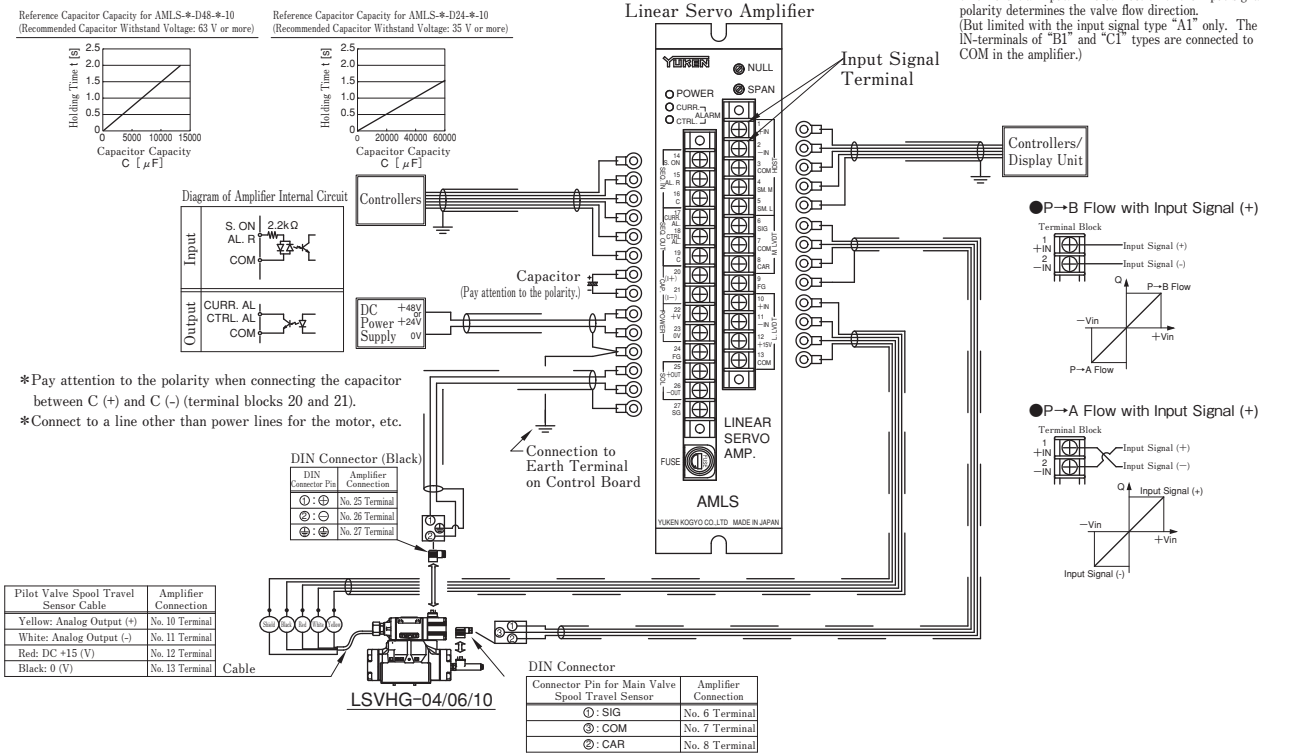

Алматы (7273)495-231
 Ангарск (3955)60-70-56
 Архангельск (8182)63-90-72
 Астрахань (8512)99-46-04
 Барнаул (3852)73-04-60
 Белгород (4722)40-23-64
 Благовещенск (4162)22-76-07
 Брянск (4832)59-03-52
 Владивосток (423)249-28-31
 Владикавказ (8672)28-90-48
 Владимир (4922)49-43-18
 Волгоград (844)278-03-48
 Вологда (8172)26-41-59
 Воронеж (473)204-51-73
 Екатеринбург (343)384-55-89

Иваново (4932)77-34-06
 Ижевск (3412)26-03-58
 Иркутск (395)279-98-46
 Казань (843)206-01-48
 Калининград (4012)72-03-81
 Калуга (4842)92-23-67
 Кемерово (3842)65-04-62
 Киров (8332)68-02-04
 Коломна (4966)23-41-49
 Кострома (4942)77-07-48
 Краснодар (861)203-40-90
 Красноярск (391)204-63-61
 Курган (3522)50-90-47
 Курск (4712)77-13-04
 Липецк (4742)52-20-81

Магнитогорск (3519)55-03-13
 Москва (495)268-04-70
 Мурманск (8152)59-64-93
 Набережные Челны (8552)20-53-41
 Нижний Новгород (831)429-08-12
 Новокузнецк (3843)20-46-81
 Новосибирск (383)227-86-73
 Ноябрьск (3496)41-32-12
 Омск (3812)21-46-40
 Орел (4862)44-53-42
 Оренбург (3532)37-68-04
 Пенза (8412)22-31-16
 Пермь (342)205-81-47
 Петрозаводск (8142)55-98-37
 Псков (8112)59-10-37

Ростов-на-Дону (863)308-18-15
 Рязань (4912)46-61-64
 Самара (846)206-03-16
 Санкт-Петербург (812)309-46-40
 Саратов (8342)22-96-24
 Саратов (845)249-38-78
 Севастополь (8692)22-31-93
 Симферополь (3652)67-13-56
 Смоленск (4812)29-41-54
 Сочи (862)225-72-31
 Ставрополь (8652)20-65-13
 Сургут (3462)77-98-35
 Сыктывкар (812)25-95-17
 Тамбов (4752)50-40-97
 Тверь (4822)63-31-35

Тольятти (8482)63-91-07
 Томск (3822)98-41-53
 Тула (4872)33-79-87
 Тюмень (3452)66-21-18
 Улан-Удэ (3012)59-97-51
 Ульяновск (8422)24-23-59
 Уфа (347)229-48-12
 Хабаровск (4212)92-98-04
 Чебоксары (8352)28-53-07
 Челябинск (351)202-03-61
 Череповец (8202)49-02-64
 Чита (3022)38-34-83
 Якутск (4112)23-90-97
 Ярославль (4852)69-52-93