

Алматы (7273)495-231  
 Ангарск (3955)60-70-56  
 Архангельск (8182)63-90-72  
 Астрахань (8512)99-46-04  
 Барнаул (3852)73-04-60  
 Белгород (4722)40-23-64  
 Благовещенск (4162)22-76-07  
 Брянск (4832)59-03-52  
 Владивосток (423)249-28-31  
 Владикавказ (8672)28-90-48  
 Владимир (4922)49-43-18  
 Волгоград (844)278-03-48  
 Вологда (8172)26-41-59  
 Воронеж (473)204-51-73  
 Екатеринбург (343)384-55-89

Иваново (4932)77-34-06  
 Ижевск (3412)26-03-58  
 Иркутск (395)279-98-46  
 Казань (843)206-01-48  
 Калининград (4012)72-03-81  
 Калуга (4842)92-23-67  
 Кемерово (3842)65-04-62  
 Киров (8332)68-02-04  
 Коломна (4966)23-41-49  
 Кострома (4942)77-07-48  
 Краснодар (861)203-40-90  
 Красноярск (391)204-63-61  
 Курган (3522)50-90-47  
 Курск (4712)77-13-04  
 Липецк (4742)52-20-81

Магнитогорск (3519)55-03-13  
 Москва (495)268-04-70  
 Мурманск (8152)59-64-93  
 Набережные Челны (8552)20-53-41  
 Нижний Новгород (831)429-08-12  
 Новокузнецк (3843)20-46-81  
 Новосибирск (383)227-86-73  
 Ноябрьск (3496)41-32-12  
 Омск (3812)21-46-40  
 Орел (4862)44-53-42  
 Оренбург (3532)37-68-04  
 Пенза (8412)22-31-16  
 Пермь (342)205-81-47  
 Петрозаводск (8142)55-98-37  
 Псков (8112)59-10-37

Ростов на Дону (863)308-18-15  
 Рязань (4912)46-61-64  
 Самара (846)206-03-16  
 Санкт-Петербург (812)309-46-40  
 Саранск (8342)22-96-24  
 Саратов (845)249-38-78  
 Севастополь (8692)22-31-93  
 Симферополь (3652)67-13-56  
 Смоленск (4812)29-41-54  
 Сочи (862)225-72-31  
 Ставрополь (8652)20-65-13  
 Сургут (3462)77-98-35  
 Сыктывкар (8212)25-95-17  
 Тамбов (4752)50-40-97  
 Тверь (4822)63-31-35

Тольятти (8482)63-91-07  
 Томск (3822)98-41-53  
 Тула (4872)33-79-87  
 Тюмень (3452)66-21-18  
 Улан-Удэ (3012)59-97-51  
 Ульяновск (8422)24-23-59  
 Уфа (347)229-48-12  
 Хабаровск (4212)92-98-04  
 Чебоксары (8352)28-53-07  
 Челябинск (351)202-03-61  
 Череповец (8202)49-02-64  
 Чита (3022)38-34-83  
 Якутск (4112)23-90-97  
 Ярославль (4852)69-52-93

Россия +7(495)268-04-70

Казахстан +7(7172)727-132

Киргизия +996(312)96-26-47

yne@nt-rt.ru || <https://yuken.nt-rt.ru>

Valve Type	Graphic Symbols	Maximum Operating Pressure MPa	Rated Flow L/min													Page
			1	2	3	5	10	20	30	50	100	200	300	500	1000	
Directional Control Logic Valves Directional and Flow Control Logic Valves		31.5	LD													G-4
Solenoid Operated Directional Control Logic Valves			LDS													G-5
Relief Logic Valves			LB													G-6
Solenoid Controlled Relief Logic Valves			LBS													G-7

Consult Yuken when detailed material such as dimensions figures is required.

## Logic Valves

Yuken Logic Valves comprise cartridge typed elements and covers with pilot passages. Various types may be combined for direction, flow rate and pressure control. Yuken Logic Valves can be incorporated in manifold blocks to form optimum integrated hydraulic circuits and compact hydraulic power units. Being a poppet type, the elements permit high-pressure, high flow rates, high speed and shockless shifting with low pressure drop. Typical applications include steel mill equipment, injection moulding machines, machine tools and so on. In addition, YUKEN's logic valves meet the cavity specifications (element insertion holes and cover mounting dimensions) of the ISO standard (ISO7368 TWO-PORT SLIP-IN CARTRIDGE VALVES CAVITIES).

### ■ Features

- Multifunction performance in terms of direction, flow and pressure can be obtained by combining elements and covers.
- Poppet-type elements virtually eliminate internal leakage and hydraulic locking. Because there are no overlaps, response times are very high, permitting high-speed shifting.
- For high pressure, large capacity systems, optimum performance is achieved with low pressure losses.
- Since the logic valves are directly incorporated in cavities provided in blocks, the system is free from problems related to piping such as oil leakage, vibration and noise, and higher reliability is achieved.
- Multifunction logic valves permit compact integrated hydraulic systems which reduce manifold dimensions and mass and achieve lower cost conventional types.

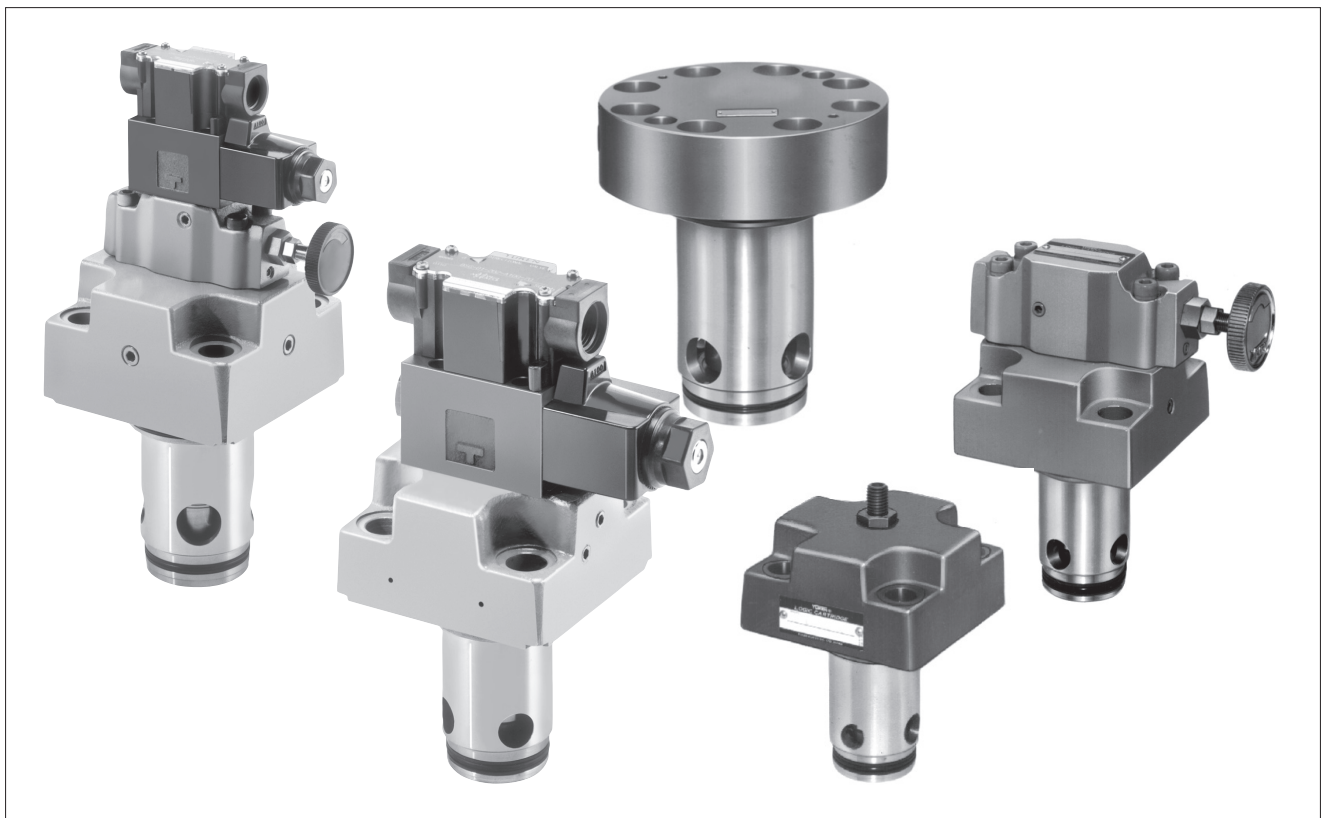
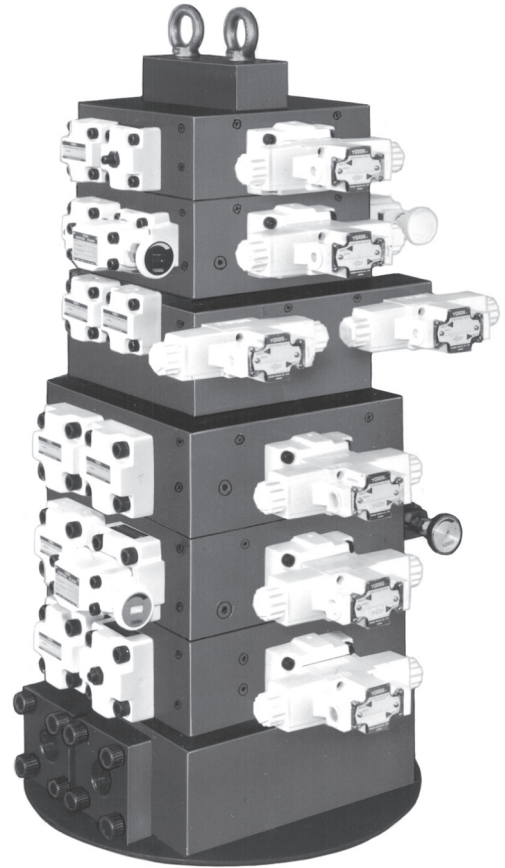

## Structure and Functions

As shown below, a logic valve consists of a cover, a sleeve, a poppet and a spring incorporated in a block. Although it is a simple two-port valve designed to open and close the poppet in accordance with the pressure signals from the pilot line, it serves as a multifunctional valve for controlling the direction, flow and pressure by controlling the pressure signals. Standard covers have several pressure signal ports (pilot ports) and control valves for control purposes are available. The covers are spigot mounted. There is no risk of oil leakage.

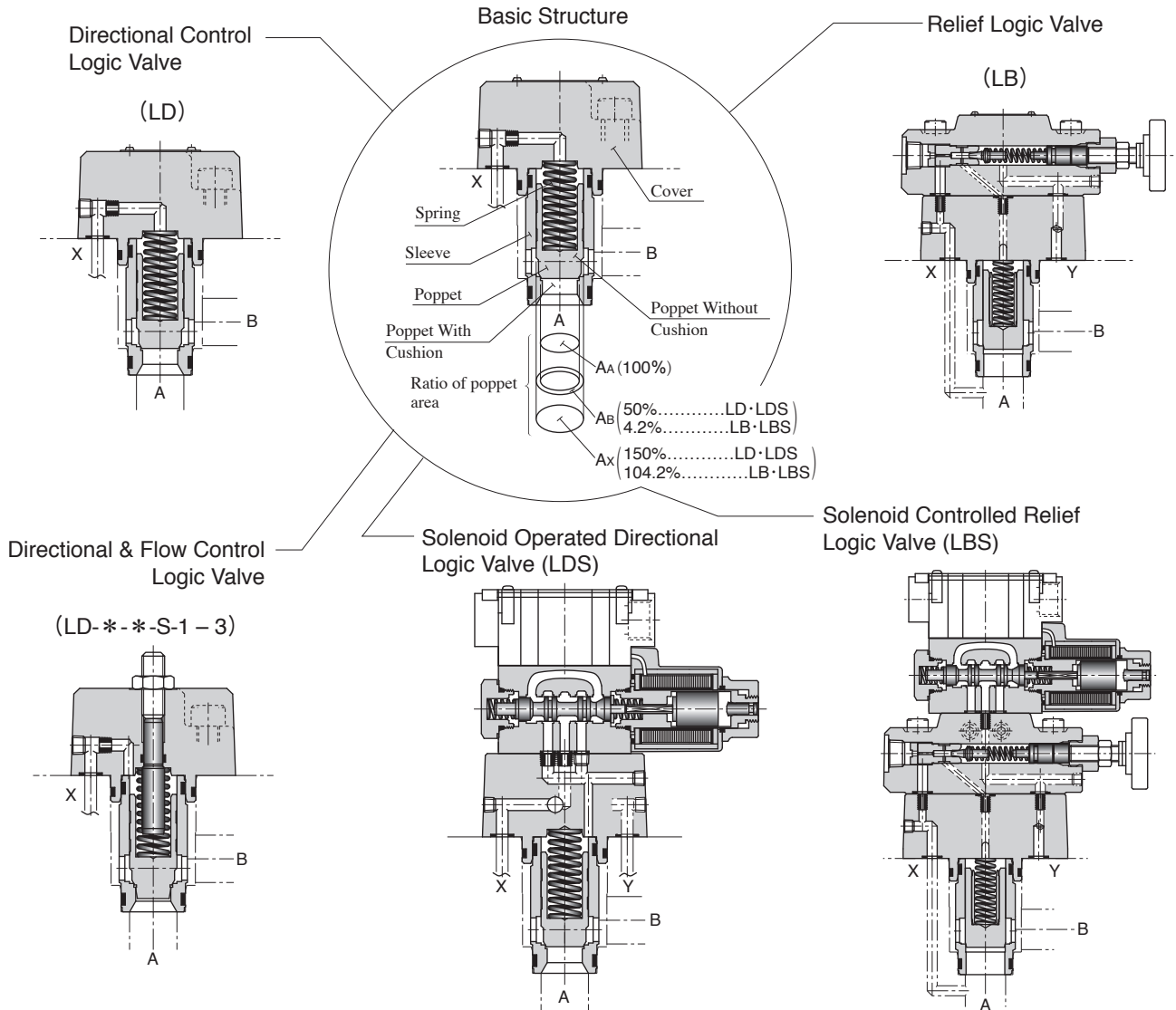

### ● Functions, working area ratios and features

Functions	Graphic Symbols	Working area ratios (AA : AB)	Features
Direction		2 : 1	<ul style="list-style-type: none"> <li>● Poppet Shape Without cushion (<math>\frac{LD}{LDS} - * - *</math>) : High-speed shift</li> <li>● With cushion (<math>\frac{LD}{LDS} - * - * - S</math>) : Shockless shift</li> <li>● No leakage between port A and B.</li> <li>● Flow A to B and B to A are possible.</li> <li>● Response time and shock can be adjusted by orifice selection.</li> </ul>
Direction and Flow			<ul style="list-style-type: none"> <li>● Poppet Shape With cushion (<math>\frac{LD - * - * - S}{3}</math>) : Flow control</li> <li>● No leakage between port A to B.</li> <li>● Flow A to B only is possible.</li> <li>● Response time and shock can be adjusted by orifice selection.</li> </ul>
Relief		24 : 1	<ul style="list-style-type: none"> <li>● Remote and unloading control is possible with vent circuit. (LB- * - *)</li> <li>● Two or three pressure controls are possible in combination of solenoid operated directional valve and pilot relief valve. (LBS- * - *)</li> </ul>

# Directional Control/Directional & Flow Control Logic Valves

These valves are 2-way directional valves designed to open and close the circuits in accordance with pressure signals from the pilot lines. They are used as multifunctional valves for controlling flow directions or flow directions and rates. Standard covers are available so that optimum valves can be selected for control purposes.

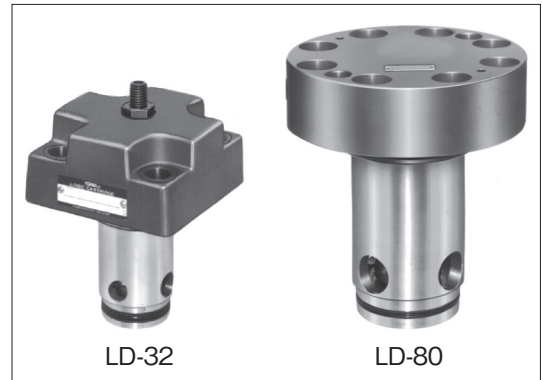

## Specifications

Model No.	(NOTE) Rated Flow L/min	Max. Operating Pressure MPa	Cracking Pressure MPa	Ratio of Poppet Area  (Annular area 50%)	Mass kg
LD-16	130	31.5	Refer to Model No. Designation	2 : 1	1.6
LD-25	350				3.0
LD-32	500				5.3
LD-40	850				9.1
LD-50	1400				14.8
LD-63	2100				29.8
LD-80	3400				48
LD-100	5500				86

Note: The rated flow is values with a pressure drop of 0.3 MPa, fluid viscosity 35 mm<sup>2</sup>/s.

## Model Number Designation

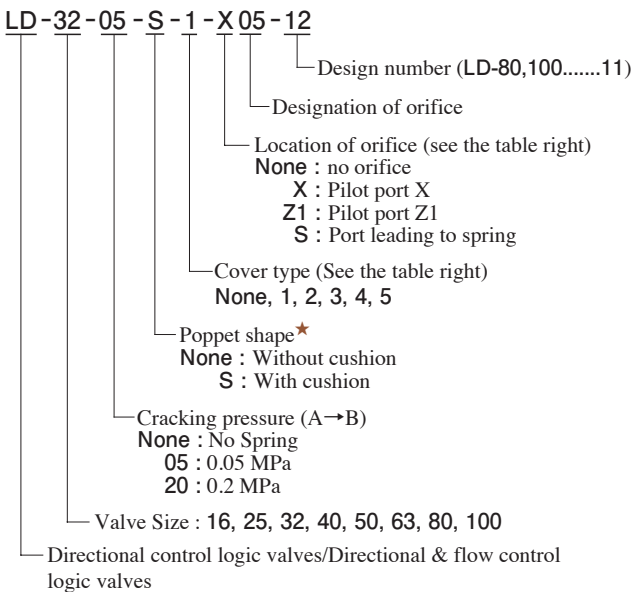

### ★Poppet shapes

The type without a cushion and the type with a cushion are both suitable for high-speed shifting and shockless shifting respectively. For directional and flow control logic valves, be sure to specify "poppet with cushions".

## List of Cover Types

Cover Type Designation	Graphic Symbols	Valve Size							
		16	25	32	40	50	63	80	100
Directional Control	Standard (None)								
	With Check Valve (4)								
	With Shuttle Valve (5)								
Directional & Flow Control	With Stroke Adjuster (1)								
	With Check Valve & Stroke Adjuster (2)								
	With Shuttle Valve & Stroke Adjuster (3)								

# Solenoid Operated Directional Control Logic Valves

These solenoid operated directional control logic valves are composed of directional control valves and solenoid operated directional valves combined together. The solenoid operated directional valves serve to switch pilot lines and the directional control valves are used to control the direction of the main circuits. Standard covers provided with various control valves are available to provide optimum control.

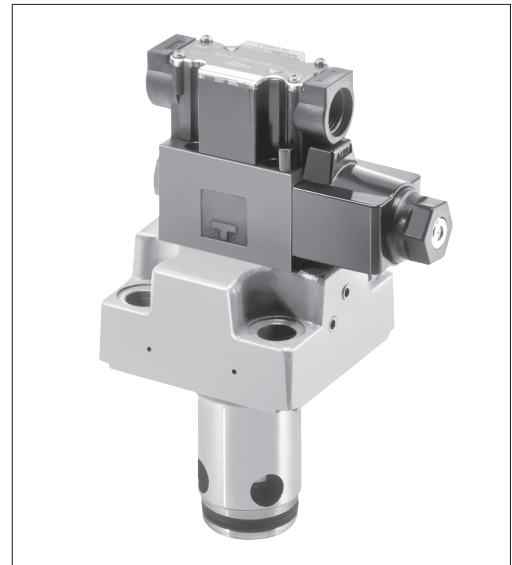

## Specifications

Model No.	(NOTE) Rated Flow L/min	Max. Operating Pressure MPa	Cracking Pressure MPa	Ratio of Poppet Area ( Annular area 50% )	Mass kg
LDS-25	350	31.5	Refer to Model No. Designation	2 : 1	4.2
LDS-32	500				6.5
LDS-40	850				10.3
LDS-50	1400				18.6
LDS-63	2100				33.6

Note: The rated flow is values with a pressure drop of 0.3 MPa, fluid viscosity 35 mm<sup>2</sup>/s.

## Model Number Designation

LDS-32-05-S-1-O-X 05-A100-C-N-14

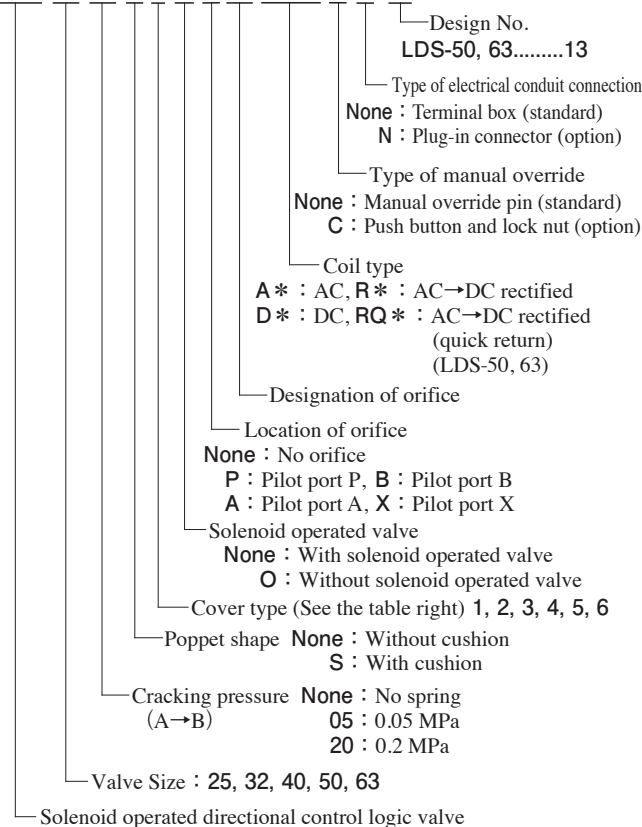

## List of Cover Types

Cover Type Designation	Graphic Symbols	Valve Size				
		25	32	40	50	63
Normally Closed (1)		<input type="radio"/>	<input type="radio"/>	<input type="radio"/>	<input type="radio"/>	<input type="radio"/>
Normally Open (2)		<input type="radio"/>	<input type="radio"/>	<input type="radio"/>	<input type="radio"/>	<input type="radio"/>
Normally Closed with Shuttle Valve (3)		<input type="radio"/>	<input type="radio"/>	<input type="radio"/>	<input type="radio"/>	<input type="radio"/>
Normally Open with Shuttle Valve (4)		<input type="radio"/>	<input type="radio"/>	<input type="radio"/>	<input type="radio"/>	<input type="radio"/>
Normally Closed with Shuttle Valve (5)		<input type="radio"/>	<input type="radio"/>	<input type="radio"/>	<input type="radio"/>	<input type="radio"/>
Normally Open with Shuttle Valve (6)		<input type="radio"/>	<input type="radio"/>	<input type="radio"/>	<input type="radio"/>	<input type="radio"/>

Note: In case of LDS- \* - \* - \* - \* - O (without solenoid operated valve), the graphic symbol for the solenoid operated valve is excluded.

# Relief Logic Valves

These relief logic valves are used to protect pumps and control valves from excessive pressure and control the pressures of their hydraulic lines at constant levels. With the help of vent lines (Z1 or Z2 port), they are also capable of remote and unload control.

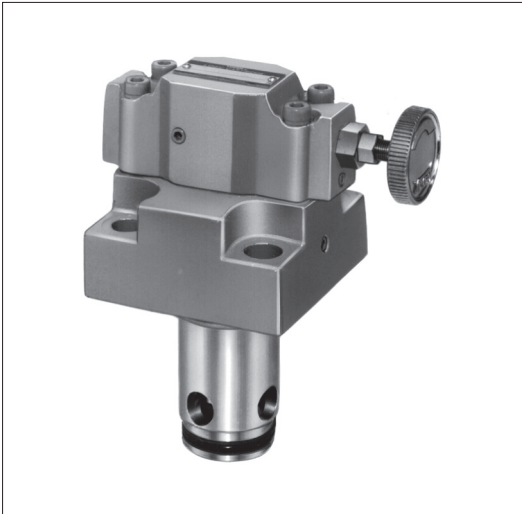

## Specifications

Model No.	Max. Operating Pressure MPa	Pres. Adj. Range MPa	Max. Flow L/min	Mass kg
LB-16- * - * -10	31.5	0.5 - 31.5	125	3.6
LB-25- * - * -10			250	4.5
LB-32- * - * -11			500	6.7
LB-50- * - * -11			1200	16.1

## Model Number Designation

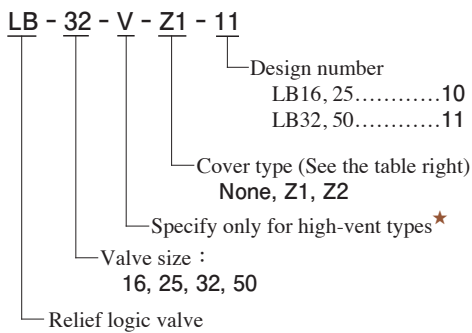

★Use high-vent pressure types if the shifting time from unloading to on-loading is reduced.

## List of Cover Types

Cover Type Designation	Graphic Symbols	Valve Size			
		16	25	32	50
Standard (None)		<input type="radio"/>	<input type="radio"/>	<input type="radio"/>	<input type="radio"/>
Vent Controlled (Z1)		<input type="radio"/>	<input type="radio"/>	<input type="radio"/>	<input type="radio"/>
Vent Controlled (Z2)		<input type="radio"/>	<input type="radio"/>	<input type="radio"/>	<input type="radio"/>

## Solenoid Controlled Relief Logic Valves

These solenoid controlled relief logic valves are composite control valves having solenoid controlled directional and pilot relief valves and vent restrictors combined together. They are used to put pumps into unloading operation, with the solenoid controlled directional valves serving to select pilot lines, or to place hydraulic system two or three pressure controls, with the pilot relief valves in action.

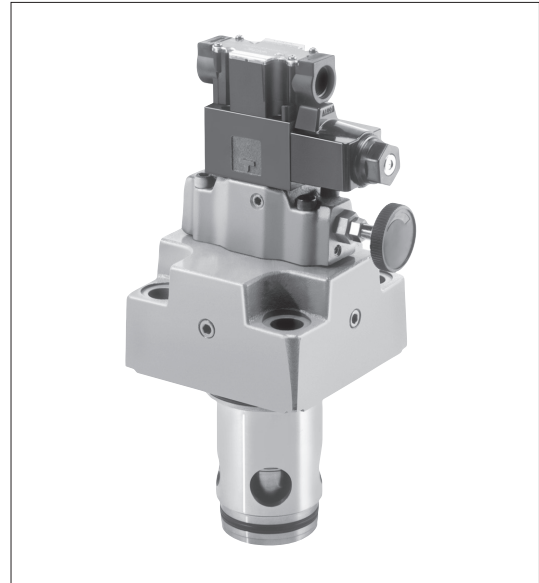

### Specifications

Model Numbers	Max. Operating Pressure MPa	Pres. Adj. Range MPa	Max. Flow L/min	Mass kg
LBS-16-***-14	31.5	0.5 - 31.5	125	3.6 - 8.5
LBS-25-***-14			250	4.5 - 9.4
LBS-32-***-14			500	6.7 - 11.6
LBS-50-***-14			1200	16.1 - 21.0

### Model Number Designation

LBS - 32 - V - 1 - A100 - C - N - 14

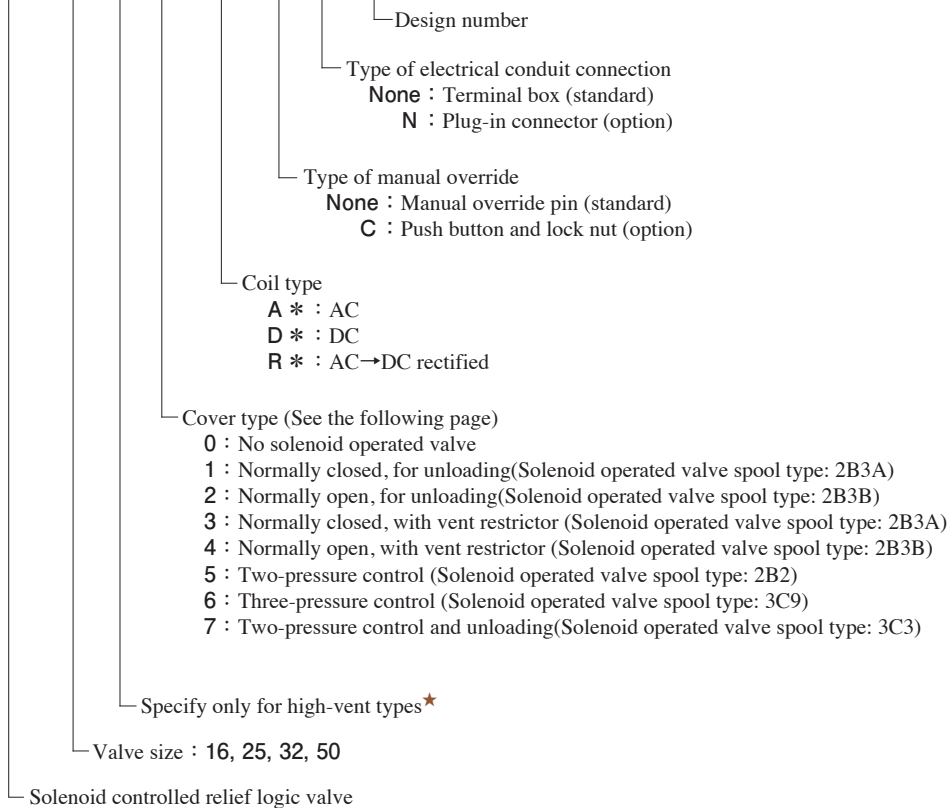

★Use high-vent pressure types if the shifting time from unloading to on-loading is reduced.



■ List of Cover Type (LBS)

Cover Type Designation	Graphic Symbols	Valve Size			
		16	25	32	50
Without Solenoid Valve (0)		<input type="radio"/>	<input type="radio"/>	<input type="radio"/>	<input type="radio"/>
Normally Closed for Unloading (1)		<input type="radio"/>	<input type="radio"/>	<input type="radio"/>	<input type="radio"/>
Normally Open for Unloading (2)		<input type="radio"/>	<input type="radio"/>	<input type="radio"/>	<input type="radio"/>
Normally Closed with Vent Restrictor (3)		<input type="radio"/>	<input type="radio"/>	<input type="radio"/>	<input type="radio"/>
Normally Open with Vent Restrictor (4)		<input type="radio"/>	<input type="radio"/>	<input type="radio"/>	<input type="radio"/>
Two Pressure Control (5)		<input type="radio"/>	<input type="radio"/>	<input type="radio"/>	<input type="radio"/>

Cover Type Designation	Graphic Symbols	Valve Size			
		16	25	32	50
Three Pressure Control (6)		<input type="radio"/>	<input type="radio"/>	<input type="radio"/>	<input type="radio"/>
Two Pressure Control and Unloading (7)		<input type="radio"/>	<input type="radio"/>	<input type="radio"/>	<input type="radio"/>

Алматы (7273)495-231  
 Ангарск (3955)60-70-56  
 Архангельск (8182)63-90-72  
 Астрахань (8512)99-46-04  
 Барнаул (3852)73-04-60  
 Белгород (4722)40-23-64  
 Благовещенск (4162)22-76-07  
 Брянск (4832)59-03-52  
 Владивосток (423)249-28-31  
 Владикавказ (8672)28-90-48  
 Владимир (4922)49-43-18  
 Волгоград (844)278-03-48  
 Вологда (8172)26-41-59  
 Воронеж (473)204-51-73  
 Екатеринбург (343)384-55-89

Иваново (4932)77-34-06  
 Ижевск (3412)26-03-58  
 Иркутск (395)279-98-46  
 Казань (843)206-01-48  
 Калининград (4012)72-03-81  
 Калуга (4842)92-23-67  
 Кемерово (3842)65-04-62  
 Киров (8332)68-02-04  
 Коломна (4966)23-41-49  
 Кострома (4942)77-07-48  
 Краснодар (861)203-40-90  
 Красноярск (391)204-63-61  
 Курган (3522)50-90-47  
 Курск (4712)77-13-04  
 Липецк (4742)52-20-81

Магнитогорск (3519)55-03-13  
 Москва (495)268-04-70  
 Мурманск (8152)59-64-93  
 Набережные Челны (8552)20-53-41  
 Нижний Новгород (831)429-08-12  
 Новокузнецк (3843)20-46-81  
 Новосибирск (383)227-86-73  
 Ноябрьск (3496)41-32-12  
 Омск (3812)21-46-40  
 Орел (4862)44-53-42  
 Оренбург (3532)37-68-04  
 Пенза (8412)22-31-16  
 Пермь (342)205-81-47  
 Петрозаводск (8142)55-98-37  
 Псков (8112)59-10-37

Ростов на Дону (863)308-18-15  
 Рязань (4912)46-61-64  
 Самара (846)206-03-16  
 Санкт-Петербург (812)309-46-40  
 Саранск (8342)22-96-24  
 Саратов (845)249-38-78  
 Севастополь (8692)22-31-93  
 Симферополь (3652)67-13-56  
 Смоленск (4812)29-41-54  
 Сочи (862)225-72-31  
 Ставрополь (8652)20-65-13  
 Сургут (3462)77-98-35  
 Сыктывкар (8212)25-95-17  
 Тамбов (4752)50-40-97  
 Тверь (4822)63-31-35

Тольятти (8482)63-91-07  
 Томск (3822)98-41-53  
 Тула (4872)33-79-87  
 Тюмень (3452)66-21-18  
 Улан-Удэ (3012)59-97-51  
 Ульяновск (8422)24-23-59  
 Уфа (347)229-48-12  
 Хабаровск (4212)92-98-04  
 Чебоксары (8352)28-53-07  
 Челябинск (351)202-03-61  
 Череповец (8202)49-02-64  
 Чита (3022)38-34-83  
 Якутск (4112)23-90-97  
 Ярославль (4852)69-52-93